

# LARRE

4th Edition Rulebook

Player  
Version







# 3<sup>rd</sup> Edition Rulebook

Player Version

Version 10.31.2009



# LAIRE Rulebook, 3<sup>rd</sup> Edition

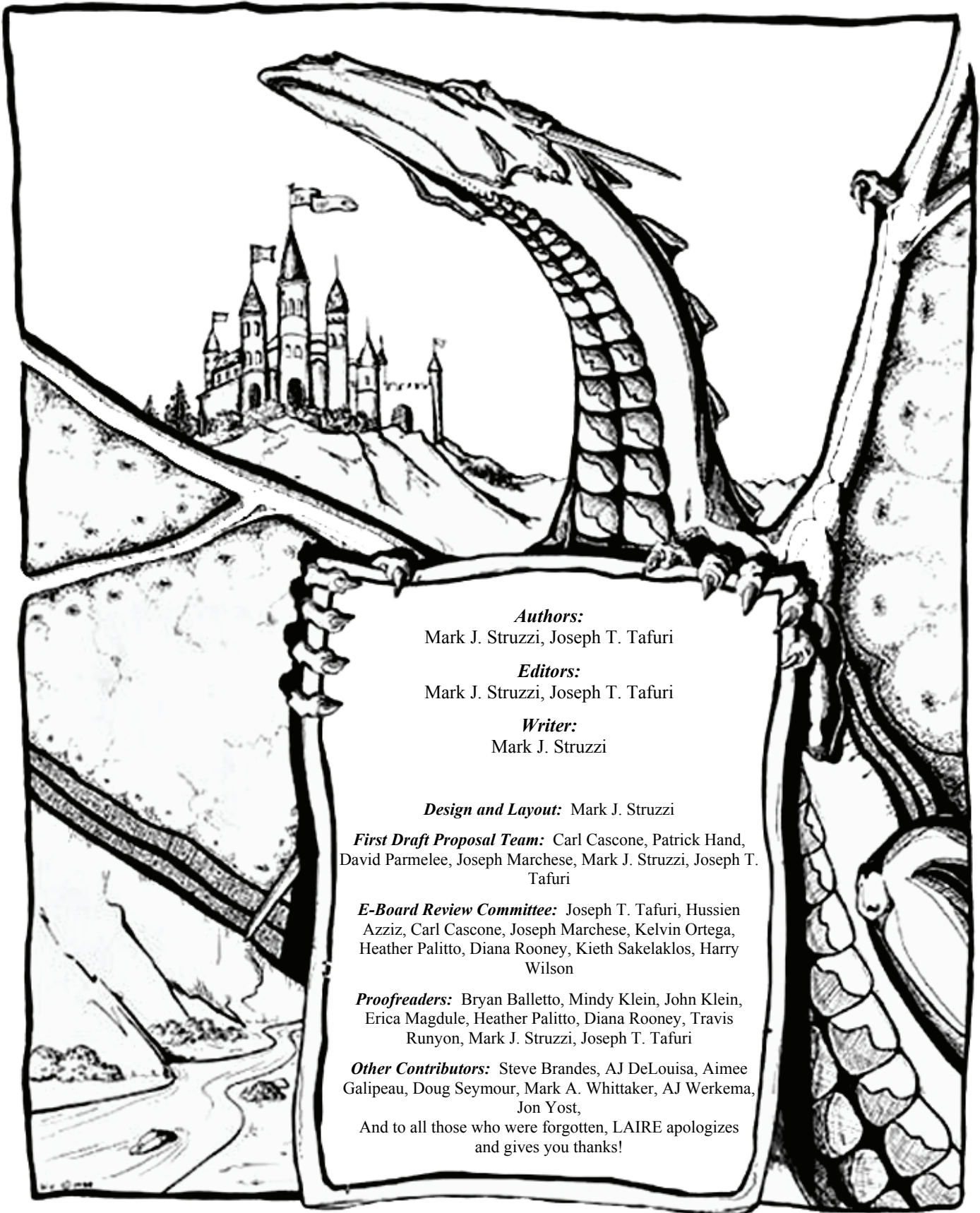

***Authors:***

Mark J. Struzzi, Joseph T. Tafuri

***Editors:***

Mark J. Struzzi, Joseph T. Tafuri

***Writer:***

Mark J. Struzzi

***Design and Layout:*** Mark J. Struzzi

***First Draft Proposal Team:*** Carl Cascone, Patrick Hand,  
David Parmelee, Joseph Marchese, Mark J. Struzzi, Joseph T.  
Tafuri

***E-Board Review Committee:*** Joseph T. Tafuri, Hussien  
Azziz, Carl Cascone, Joseph Marchese, Kelvin Ortega,  
Heather Palitto, Diana Rooney, Kieth Sakelaklos, Harry  
Wilson

***Proofreaders:*** Bryan Balletto, Mindy Klein, John Klein,  
Erica Magdule, Heather Palitto, Diana Rooney, Travis  
Runyon, Mark J. Struzzi, Joseph T. Tafuri

***Other Contributors:*** Steve Brandes, AJ DeLouisa, Aimee  
Galipeau, Doug Seymour, Mark A. Whittaker, AJ Werkema,  
Jon Yost,

And to all those who were forgotten, LAIRE apologizes  
and gives you thanks!



# LAIRE Rulebook, 3<sup>rd</sup> Edition

## Preface

I have asked for the privilege of writing the preface for this rulebook. While I have not worked on this project from the very beginning, it has been a long time dream to see this kind of rulebook in the hands of the players. My first Event at LAIRE was May 1991, the first Event LAIRE became LAIRE. Before that, this organization existed as a NERO chapter. My friend, after much diligent persuasion, convinced me to sit down and learn the NERO rules and make a character. After arriving at the Event, we learned the organization was no longer associated with NERO. The organization had a new name, LAIRE, and now had their own set of rules that were similar, but not the same. If that was not difficult enough, just after learning those rules, the E-Board announced a new set of rules and, in August of 1993, LAIRE had the 2<sup>nd</sup> Edition Rulebook. Very quickly afterwards, new master skill list packets began to emerge and characters had many new options. For many years this trend continued as new and old ideas became playable skill lists. Paladins, for example, had at one time four skills: Heal Wounds, Life, Turn Lesser Undead, Turn Undead Horde until they have grown into the Advanced Career Skill List you see in this document.

Eventually, the E-Board decided the game needed to review and finalize all the new, and old, skills and skill lists into a new rulebook. It is at this point my involvement began. So in 1996 the first rules committee for the 3<sup>rd</sup> Edition rulebook began. After about a year, all the skill lists – except Sorcery – were completed. Then the committee broke up, some people moved on with their lives, others no longer wished to continue with the project. The document sat unfinished on a virtual shelf for a long time. The rules themselves found their way into the game and were played, used, broken and fixed through innumerable number of marshal calls only to be re-interpreted again at a later date. Once again, the organization realized it needed a new rulebook.

Many executive directors and their committees worked on the document; taking what was done in the past and working on and modifying the document. They tried with all good intent to take the collection of independent skills and skill lists and make a consistent, cohesive rules set. As the term of each executive director ended, so did the drive to complete the rulebook. This continued until May 2004 when the new executive director at the time, Joe Tafuri, approached me to help him finish this project that he and I started eight years ago. The goal was to create that consistent, cohesive rulebook that was also balanced and most importantly, fun. Finally, after many, many hard hours of work – several thousand man-hours of work all told – the rulebook is completed just over two years later.

But sadly, as Joe points out to me, it is not complete. This document will never truly be complete. As new rules, errors, and oversights change this document over the years, the true living nature of this document comes to light. What will the rulebook look like in ten years from now? I can not imagine, but I can hope that the work and effort done here carries over into that future document, just as the hard work and ideas of those who have come before me have their place in this document.

As I said earlier, the point of all this is to create a game that is fun. It is my wish that you, the reader, will use this rulebook to create for yourself a great fantasy story born out of your wildest imagination. So read this book, learn the rules, and go out and adventure in the lands of Midlantia!

Mark J Struzzi

## Additional Credits

### *The first 3<sup>rd</sup> Edition Rules Committee:*

DJ Aronson, Kirsten Evers, Greg Heleki, Oed Kenny, Tony Klett, Eugene McCrohan, Erich Michel, Doug Milne, Mark J. Struzzi, Joseph T. Tafuri.

### *The 2<sup>nd</sup> Edition Rulebook Credits:*

#### *The Rules:*

The rules were written, edited, and reviewed by the members of the Executive Committee of LAIRE from January 1993 through August 1993: Hindy Brandes, Steve Brandes, Doug Goldberg, Oed Kenny, Rob Lardiere, Rich Link, John Mackay, Doug Milne, Bill Seligman, Bob Suliga, Eric Turqman, Louisa Turqman, Mary Beth Turqman

*Additional review by:* Dave Brandes, Brian Dynda, Tony Kukal, Scott Melzer, Raul Ravelo

*Typing, page layout, and production:* Bill Seligman

*Layout Assistance:* Raul Ravelo

*Proofreading:* Andy Besold, Kirsten Evers, Lorenz Pogue, Jeff Reichart, Craig Silberman

*Production Assistance:* Lisa Pinkham



# Table of Contents

## Chapter 1: Introduction to LAIRE... 1

<u>Welcome to LAIRE!</u>	<u>2</u>
<u>Introduction to LAIRE</u>	<u>2</u>
<i>Using This Rulebook</i>	2
<i>What is a Live-Action Roleplaying Game</i>	2
<i>The Action</i>	2
<i>The Fantasy World</i>	2
<i>Winning and Losing</i>	2
<u>A Sample Adventure</u>	<u>3</u>

## Basic Game Rules and Concepts 10

<i>The First Rule</i>	10
<i>Characters and Players</i>	10
<i>Tag Cycles and Using Skills</i>	10
<i>Rounding Rules</i>	10
<i>Losing Permanent Pool Points or Body Points</i>	10
<i>Rule Conflicts</i>	10
The Hold Rule	10
<i>What Happens When You Call a Hold</i>	10
<i>How to Call a Hold</i>	10
<i>When to Call a Hold</i>	10
<i>What is not allowed during a Hold</i>	10
<i>The Word Hold In-game</i>	11
Weapons, Magic and Taking Damage	11
<i>Striking With a Weapon</i>	11
<i>Calling Damage</i>	11
<i>Additions to Normal Damage</i>	11
<i>When You Do Not Call Full Damage</i>	12
<i>Taking Damage</i>	12
<i>Illegal Combat Maneuvers</i>	12
<i>Legal Contact in Combat</i>	12
Death and Dying	13
<i>Types of Injury</i>	13
<i>Death and Recovery</i>	13
<i>Unconsciousness</i>	13
<i>Bleeding to Death</i>	13
<i>Mortally Wounded</i>	13
<i>Dying</i>	14
<i>Death</i>	14
<i>Killing Blows</i>	14
<i>After Your Character is Dead</i>	14
In-game vs. Out-of-game	14
<i>In-game Behavior</i>	15
<i>Out-of-game Behavior</i>	15
<i>Going In- and Out-of-Game</i>	15
<i>Out-of-Game Areas</i>	15
<i>Abuse of the System</i>	15
<i>Sleeping In-Game</i>	16

## Basic Game Play 16

Logistics and Check-in	16
<i>The Character Card</i>	16
<i>Checking Out</i>	16
<i>Up Keep</i>	17
PC'ing	17
NPC'ing	17

Brownie and Play Credits	17
<i>How to Spend Brownie Points</i>	17
<i>Earning Brownie Points</i>	18
<i>LAIRECash</i>	18
<i>Play Credits</i>	18
The Tag System	18
Character Tags	18
<i>Body Points</i>	18
<i>Skill Tags</i>	18
<i>Pool Points</i>	18
Tag Exchanges	18
<i>Tag Cycles</i>	19

## Chapter 2: Creating a Character... 21

### Character Background 22

The Basic Questions	22
<i>What Can Your Character Do?</i>	22
<i>What Does Your Character Want to Become?</i>	22
<i>What Does Your Character Look Like?</i>	22
The Character Description	22
<i>What is the Story Behind Your Character?</i>	22
<i>What Obstacles Must Your Character Overcome?</i>	22
<i>What Are Your Character's Goals?</i>	22
<i>Questions to ask When Developing a Character</i>	23
<i>Common Problems</i>	23

### Creating a Character 23

### Character Races and Tribes 23

<i>Costuming Do's and Don'ts</i>	24
Humans	24
<i>Common Man</i>	24
<i>Barbarians</i>	24
<i>Gypsies</i>	27
<i>Highlanders and Celts</i>	28
Elves	29
<i>Dark Elves</i>	29
<i>Gray Elves</i>	30
<i>Wood Elves</i>	30
Dwarves	31
<i>Hill Dwarves</i>	31
<i>Mountain Dwarves</i>	32
Halflings	32
Mystical Races	32
<i>Kaletani</i>	32
<i>Saurians</i>	33
<i>Wolfen</i>	34
Half Breeds	34
<i>Half Elves</i>	34
<i>Half Ogres</i>	34
<i>Half Orcs</i>	35
<i>Half Trolls</i>	36

### Introduction to Skills 37

<i>Skill Costs</i>	37
--------------------	----

### Basic Career Skill Lists 37

<i>Warrior Basic Career</i>	37
<i>Mage Basic Career</i>	38



# Table of Contents

<i>Rogue Basic Career</i> .....	38	<b>Chapter 4: Advanced Careers</b> .....	<b>81</b>
Sample Characters .....	38	<b>Alchemist Advanced Career</b> .....	<b>82</b>
Warrior Basic Career Skill List .....	40	The Alchemist.....	82
<i>Special Notes for the Warrior Basic Career Skill List</i> .....	40	Alchemy Rules .....	82
<i>Weapon Damage</i> .....	40	<i>Using Alchemical Items</i> .....	82
Mage Basic Career Skill List.....	41	<i>Special Rule of Poisons</i> .....	83
<i>Special Notes for the Mage Basic Career Skill List</i> .....	41	<i>Material Components</i> .....	83
Rogue Basic Career Skill List.....	42	<i>Alchemical Tags</i> .....	84
<i>Special Notes for the Rogue Basic Career Skill List</i> .....	42	<i>Recipe Books</i> .....	84
Miscellaneous Skill List .....	42	<i>Producing Alchemical Items</i> .....	84
<i>Special Notes for the Miscellaneous Skill List</i> .....	42	<i>Modifying Alchemical Items</i> .....	85
<i>Special Weapon Smith Rules</i> .....	43	<i>Creating a Golem</i> .....	86
<i>Special Armor Smith Rules</i> .....	44	<i>Creating New Alchemical Items</i> .....	86
<b>Earning Build and Leveling</b> .....	<b>45</b>	Alchemical Item Lists.....	87
<b>Learning and Teaching Skills</b> .....	<b>46</b>	<i>Description Headings</i> .....	87
<b>Body Points</b> .....	<b>46</b>	Poisons School.....	88
<b>Chapter 3: Magic</b> .....	<b>49</b>	Potions School.....	90
<b>How Spells Work</b> .....	<b>50</b>	Solutions School.....	93
Spell Casting 101.....	50	<i>Using Acids</i> .....	93
<i>How to Cast a Spell</i> .....	50	<b>Sorcerer Advanced Career</b> .....	<b>97</b>
<i>How to Interrupt a Spell or Fail to Cast a Spell</i> .....	50	The Sorcerer.....	97
<i>Power Points</i> .....	51	Scroll Rules.....	97
<i>Spell Verbals</i> .....	51	<i>Creating Scrolls</i> .....	97
Special Rules for Spells.....	52	Sorcery Rules .....	98
<i>Latent Spells</i> .....	52	<i>Learning and Scribing Rituals</i> .....	98
<i>Stacking Spells</i> .....	53	<i>Casting a Ritual</i> .....	99
<i>Wall Spells and Concentration Rules</i> .....	53	<i>Additional Casters in a Ritual</i> .....	99
<i>Durations</i> .....	54	<i>Additional Participants in a Ritual</i> .....	100
<i>Overspending Power Points</i> .....	54	<i>Target of the Ritual</i> .....	100
<i>Natural Immunities</i> .....	54	<i>Duration of Rituals</i> .....	100
<i>Shields and Spells</i> .....	54	<i>Creating Magic Items, Invokable versus Castable</i> .....	100
<i>Stopping Spells for Someone Else</i> .....	54	<i>Creating Magic Items – Ritual Limit</i> .....	101
<i>Casting Spells on Inanimate Objects</i> .....	54	<i>Undead Creation Rituals</i> .....	101
Learning Low Magic.....	55	<i>Components</i> .....	101
<i>Spell Books</i> .....	55	<i>Creating New Rituals</i> .....	101
New Spells.....	55	<i>Aligned Sorcery</i> .....	102
<b>Schools of Magic Descriptions</b> .....	<b>56</b>	Ritual Success Tables.....	103
Auras School.....	56	<i>Timing, Marshalling, and Performance Bonus</i> .....	104
Bonds School .....	58	<i>Ritual Flaw Tables</i> .....	104
Charms School .....	60	Rituals.....	104
Death School.....	62	<i>Description Headings</i> .....	104
Demonology School.....	63	Rank 1 Rituals .....	105
Enchantments School .....	66	Rank 2 Rituals .....	107
Healing School.....	68	Rank 3 Rituals .....	110
Ice School .....	71	Rank 4 Rituals .....	112
Necromancy School.....	72	Rank 5 Rituals .....	115
Pyrotechnics School.....	76	Rank 6 Rituals .....	118
Thaumaturgy School.....	77	<b>Spell Singer Advanced Career</b> .....	<b>120</b>
		The Spell Singer.....	120
		Spell Singing Rules .....	120
		<i>Buying Spell Singing</i> .....	120
		<i>Using Spell Singing</i> .....	121
		<i>The Songbook</i> .....	121
		<i>Losing the Song</i> .....	121
		Spell Songs .....	122

# Table of Contents

<b>Warlock Advanced Career</b> .....	<b>125</b>	<b>Servant of Darkness Advanced Careers</b> .....	<b>142</b>
The Warlock .....	125	The Dark Cleric, Dark Paladin, and Dark Sorcerer.....	142
<i>The Warlock Circle</i> .....	125	Dark Cleric, Dark Paladin, and Dark Sorcerer Rules .....	143
tjharlock Rules.....	126	<i>The Laws</i> .....	143
<i>Prerequisites and Skills</i> .....	126	<i>What is Evil?</i> .....	144
<i>The Warlock Focus</i> .....	126	<i>Honor and the Servants of Darkness</i> .....	144
<i>Red Casting Powder</i> .....	126	<i>The Dark Cleric and Dark Paladin Focus</i> .....	144
<b>Master Warrior Advanced Career</b> .....	<b>127</b>	<i>The Cardinal Oath</i> .....	144
The Master Warrior.....	127	<i>The Quest</i> .....	144
Master Warrior Rules.....	127	<i>Special Servants of Darkness Skill Rules</i> .....	144
<i>Prerequisites and Skills</i> .....	127	<i>Special Dark Sorcerer Rules</i> .....	145
<i>Using Master Warrior Skills</i> .....	128	<i>Losing Faith</i> .....	145
<i>Channeling</i> .....	128	<b>Master Miscellaneous Skills</b> .....	<b>146</b>
<b>Master Thief Advanced Career</b> .....	<b>130</b>	Master Miscellaneous Skills.....	146
The Master Thief .....	130	<i>Learning Master Miscellaneous Skills</i> .....	146
Master Thief Rules.....	130	<b>Chapter 5: Skill Descriptions</b> .....	<b>147</b>
<i>Using Master Thief Skills</i> .....	130	<b>How to Use this Chapter</b> .....	<b>148</b>
<b>Assassin Advanced Career</b> .....	<b>131</b>	<b>Skill Descriptions</b> .....	<b>149</b>
The Assassin .....	131	A .....	149
Assassin Rules .....	131	B .....	152
<i>Prerequisites and Skills</i> .....	131	C .....	153
<i>Using Assassin Skills</i> .....	131	D .....	156
<b>Follower of the Light Advanced Careers</b> .....	<b>132</b>	E .....	161
The Cleric, Paladin, and White Sorcerer.....	132	F.....	164
<i>The Order of Paladins</i> .....	133	G.....	165
<i>The House of the Sun</i> .....	133	H.....	165
Cleric, Paladin, and White Sorcerer Rules .....	134	I.....	168
<i>The Laws</i> .....	134	J .....	169
<i>Codes of Honor</i> .....	135	K.....	169
<i>The Cleric and Paladin Focus</i> .....	135	L .....	169
<i>The Cardinal Oath</i> .....	136	M.....	170
<i>The Quest</i> .....	136	N.....	172
<i>Special Follower of the Light Skill Rules</i> .....	136	O.....	173
<i>Special White Sorcerer Rules</i> .....	136	P.....	173
<i>Losing Faith</i> .....	136	Q.....	176
<b>Druid Advanced Career</b> .....	<b>137</b>	R.....	176
The Druid.....	137	S.....	178
<i>Druidic Society</i> .....	138	T .....	183
<i>Animal Totems and the Elements</i> .....	138	U .....	184
Druid Rules.....	138	V.....	184
<i>The Druidic Code</i> .....	138	W – Z.....	185
<i>The Druid's Focus</i> .....	138		
<i>Special Druid Skill Rules</i> .....	139		
<i>Special Uses for the Elemental Pool</i> .....	139		
<i>The Quest</i> .....	139		
<i>Losing Faith</i> .....	139		
Nature Magic .....	140		



# Table of Contents

<b>Chapter 6: Combat</b> .....	<b>189</b>	<b>Making a Shield</b> .....	<b>209</b>
<b>Combat Rules</b> .....	<b>190</b>	<i>Finishing Touches</i> .....	209
Weapons and Taking Damage .....	190	<b>Weapon and Shield Size Requirements</b> .....	<b>210</b>
<i>Striking With a Weapon</i> .....	190	<i>Approving Weapons</i> .....	210
<i>Calling Damage</i> .....	190	<i>The Weapon Card</i> .....	210
<i>Surprise Attacks and Using Martial Defenses</i> .....	190	<i>The Weapon Inspection</i> .....	210
<i>Additions to Normal Damage</i> .....	190	<b>Armor</b> .....	<b>211</b>
<i>When You Do not Call Full Damage</i> .....	191	Types of Armor .....	211
<i>Taking Damage</i> .....	191	Armor Point Table .....	211
Special Rules for Weapons and Shields.....	191	Assigning Armor Points .....	211
<i>Claws</i> .....	191	<i>The In-game Strength of the Armor</i> .....	212
<i>Shields</i> .....	191	<i>Real Armor Bonus</i> .....	212
<i>Illegal Combat Maneuvers</i> .....	191	<i>Rounding the Sum</i> .....	212
Legal Contact in Combat.....	192	<i>The Armor Card</i> .....	212
<i>Legal Contact in Combat</i> .....	192	<i>Armor Point Tags</i> .....	212
<i>Facial Contact</i> .....	192	<i>Resetting Armor after Combat</i> .....	212
<i>When You Are Struck Illegally</i> .....	192	<i>The Helmet and Waylay</i> .....	213
<i>When You Strike an Illegal Blow</i> .....	192	<i>Armor Repair</i> .....	213
<i>Restraining another Character</i> .....	192	Armor Notes.....	213
Killing Blows.....	193	<b>Making Packet Beanbags</b> .....	<b>214</b>
Severing Blows and Disabling a Character .....	193	Spell Packet Construction Instructions .....	214
Special Attacks.....	193	Arrow Packet Construction Instructions.....	214
<i>Other Attacks</i> .....	194	<b>Chapter 7: Playing the Game</b> .....	<b>217</b>
Parrying for another Character .....	194	<b>Glossary of Common Game Terms</b> .....	<b>218</b>
When the Battle Is Done.....	194	<b>General Rules</b> .....	<b>221</b>
<b>Death and Dying</b> .....	<b>195</b>	The Hold Rule.....	221
<i>Types of Injury</i> .....	195	<i>What Happens When You Call a Hold</i> .....	221
<i>Death and Recovery</i> .....	195	<i>How to Call a Hold</i> .....	221
<i>Life Effects</i> .....	195	<i>When to Call a Hold</i> .....	221
<i>Unconsciousness</i> .....	195	<i>What is not Allowed During a Hold</i> .....	221
<i>Bleeding to Death</i> .....	196	<i>The Word Hold In-Game</i> .....	221
<i>Mortally Wounded</i> .....	196	The First Rule.....	221
<i>Brink of Death (Dying)</i> .....	196	Characters and Players .....	221
<i>Death</i> .....	196	Tag Cycles and Using Skills.....	221
<i>Killing Blows</i> .....	196	Rounding Rules .....	222
<i>After Your Character is Dead</i> .....	196	Losing Permanent Pool Points or Body Points .....	222
The Body, Spirit, and Soul .....	197	Acknowledging an Attack .....	222
The Death System.....	197	When to Call "No Effect" .....	222
<i>How to Resurrect a Character</i> .....	198	Halving and Doubling Effects .....	222
<i>Resurrection Story Sample 1</i> .....	198	One Strike Combat Rule .....	222
<i>Resurrection Story Sample 2</i> .....	200	Courtesy.....	222
<b>Weapons</b> .....	<b>201</b>	Calling other Players on Mistakes.....	222
How to Make a Weapon.....	201	In-Game Versus Out-of-game .....	222
<i>Construction Materials</i> .....	201	<i>In-game Behavior</i> .....	223
<i>Making Daggers, Claws, Long Swords and Bastard Swords</i> .....	202	<i>Out-of-game Behavior</i> .....	223
<i>Making Staves and Pole Arms</i> .....	204	<i>Going In- and Out-of-Game</i> .....	223
<i>Making Two Handed Swords and Blunts</i> .....	206	<i>Out-of-Game Areas</i> .....	223
<i>Making Bows</i> .....	207	<i>Abuse of the System</i> .....	223
How Not to Make a Weapon.....	208	<i>Sleeping In-Game</i> .....	223
Notes on Weapon Construction .....	208	In-Game and Out-of-Game Information.....	224
<i>PVC and Pipe Insulation</i> .....	208	<i>Player to Player Information</i> .....	224
<i>The Tips of Weapons</i> .....	208	<i>NPC to Player Information</i> .....	224
<i>Long Weapons</i> .....	208	<i>Between Event "In-Game" Conversations</i> .....	224
<i>Special Weapons</i> .....	208		
Weapon Care.....	208		

# Table of Contents

<b>Player Characters (PC's)</b> .....	224	<b>Event Cycle and Timeline</b> .....	233
Player Guidelines.....	224	<b>Pages</b> .....	234
<i>Know the Rules</i> .....	224	<b>Chapter 8: Midlantia and Avalon.....</b>	<b>235</b>
<i>Be a Good Sport</i> .....	224	<b>The Duchy of Avalon</b> .....	<b>236</b>
<i>Do Not Get into Arguments About the Rules</i> .....	225	<i>The City of Avalon</i> .....	236
<i>Roleplay</i> .....	225	The County of Avalon High.....	236
<i>Stay In-Game as Much as Possible</i> .....	225	<i>The Dale</i> .....	236
<i>You are Not Your Character, Your Character is Not You</i> .....	225	<i>Medici</i> .....	236
<i>Be Prepared</i> .....	225	The County of Avalon Low.....	237
<i>Ask for Tags</i> .....	225	<i>Islewatch</i> .....	237
<i>One Last Time</i> .....	225	<i>Eastguard</i> .....	237
<b>Non-Player Characters (NPC's)</b> .....	226	<i>Ultor</i> .....	237
Why be an NPC?.....	226	<b>The History of Avalon</b> .....	<b>238</b>
Guidelines for NPC's.....	226	Ancient History.....	238
<i>Know the Rules</i> .....	226	The Exploration of the Southern Reaches.....	238
<i>Be a Good Sport</i> .....	226	The Trollish Uprising.....	239
<i>Obey the Monster Marshal</i> .....	226	The Building of the Tower Mountain Citadel.....	239
<i>Take Your Hits</i> .....	227	The Catastrophe.....	240
<i>Roleplay</i> .....	227	Conflict in Medici and the Dale.....	240
<i>The Players are not Your Opponents</i> .....	227	The Rise of the Cult.....	240
<i>Do not Give a Killing Blow to a Player Character</i> .....	227	The Fall of the Tower Mountain Citadel.....	240
<i>He also Serves Who Only Stands and Waits</i> .....	227	The Brief Reign of Duke Dragonhart.....	241
<i>Be Available</i> .....	227	The War with the Hierarchs.....	241
<i>Be Prepared</i> .....	227	The Elven War and Rise of Azeroth.....	241
<i>Keep Your Card with You at All Times</i> .....	227	The Nymidian War of 1095.....	242
<i>Ask for Tags</i> .....	227	Passing Beyond.....	243
<b>The Tag System</b> .....	227	Reign of King's Regent Derek Ironheart.....	243
The Tag System.....	227	Reign of Duke Jerrin Dragonheart.....	243
The Character Card.....	227	The Prophecy Fulfilled.....	243
NPC Cards.....	227	The Council of the Damned.....	244
Character Tags.....	228	The Ascension Wars.....	245
<i>Body Points</i> .....	228	Tarsus and the Breaking of the Seals.....	245
<i>Skill Tags</i> .....	228	The Reclaiming of the Highlands.....	245
<i>Pool Points</i> .....	228	Reign of Duke Sir Molin Hearst.....	246
Tag Exchanges.....	228	Blasphemy Freed.....	246
Component Tags.....	228	First Contacts.....	247
<i>Getting Tags for Parts Dissected During Game Play</i> .....	229	Reign of Duke Kendrick Monaghan.....	248
Alchemy Tags.....	229	The War with Graythrone and the Death of a Queen.....	248
<b>Item Cards</b> .....	229	The Kalix Invasion.....	248
<i>Magic Item Cards</i> .....	229	Nehru and Kaleb Dhur.....	249
<i>Weapon Cards</i> .....	229	The Barconian Civil War.....	249
<i>Armor Cards</i> .....	229	The Death of a King.....	249
<b>In-game, Out-of-Game, In-Play Items</b> .....	230	The Unification of Nymidia and the Rise of Emperor William Thallman.....	250
Bringing an Item In-Game.....	230	The Kurig Invasion.....	250
<b>Stealing</b> .....	231	The Conflict Over Briton.....	250
General Thievery.....	231	The Orcish Invasion of Mistwood.....	251
Searching a Character.....	231	The Ascension Wars Begin Again.....	252
<i>Simple Search</i> .....	231	Map of Avalon.....	253
<i>Complete Search</i> .....	231	<b>The Map of Avalon</b> .....	<b>253</b>
<i>Speed Search</i> .....	232		
Searching a Room or Cabin.....	232		
Hiding In-Game Items.....	233		
Securing Your Cabin - Locks and Traps.....	233		
While You are Out-of-Game.....	233		
A Final Word on Stealing.....	233		



# Table of Contents

<b>A Walk Through Avalon</b>	<b>254</b>
The Nobility of Avalon .....	254
<i>Prince Jerrin Dragonheart</i> .....	254
<i>The Duke of Avalon</i> .....	254
The Guilds of Avalon.....	254
Other Organizations .....	255
Common Laws of Avalon.....	256
Codex Nobilis .....	257
Rules of Etiquette.....	259
Economy .....	259
Calendar .....	260
<b>Map of Midlantia</b>	<b>261</b>
<b>The Realms of Midlantia</b>	<b>262</b>
The Old Nymidian Empire .....	262
The New Nymidian Empire.....	262
<i>The Duchy of Aquilar</i> .....	262
<i>The Duchy of Briton</i> .....	262
<i>The Duchy of Psynia</i> .....	262
<i>The Duchy of Tiraine</i> .....	263
<i>The Crystal City</i> .....	263
Barconia.....	263
Free Lands of Coventry .....	263
The Kingdom of the Elves .....	263
The Dwarves of the Black Hills .....	264
The Highland Home of the Highlanders and Celts.....	264
The Empire of Telvenden .....	265
Other Nations.....	265
<i>Almeida</i> .....	265
<i>Gleneden/Glenraven</i> .....	265
<i>Nasharapura</i> .....	265
<i>The Nyte Skye Isles</i> .....	265
<i>The Reaver Islands</i> .....	265
<i>The Great White Swamp</i> .....	265
<i>The City State of Tenthetra</i> .....	265
Significant Places.....	266
<i>Arcana</i> .....	266
<i>Azygoüz</i> .....	266
<i>The Black Hills</i> .....	266
<i>Castle duRhone</i> .....	266
<i>Darkwood</i> .....	266
<i>The Great Northern Ice</i> .....	266
<i>The Lands of Ice and Snow</i> .....	266
<i>The Plains of Gehenna</i> .....	266
<i>The Underdark</i> .....	266
<i>The Wolfskäl Mountains</i> .....	266

## Chapter 9: The Organization of LAIRE... 269

### LAIRE Rules and Procedures 270

The LAIRE Constitution.....	270
<i>ARTICLE I, NAME</i> .....	270
<i>ARTICLE II, PURPOSE</i> .....	270
<i>ARTICLE III, MEMBERSHIP</i> .....	270
<i>ARTICLE IV, EXECUTIVE BOARD</i> .....	270
<i>ARTICLE V, CONDUCT OF E-BOARD AND E-BOARD MEETINGS</i> .....	272
<i>ARTICLE VI, SELECTION AND REPLACEMENT OF E-BOARD MEMBERS</i> .....	272
<i>ARTICLE VII, ELECTIONS</i> .....	273
<i>Article VIII, Changing Organizational Rules and Procedures</i> .....	273
Disciplinary Actions.....	273

### Working for LAIRE 273

Donations .....	273
Marshals.....	273
Staff Positions.....	274
E-Board .....	274
Rewards for Working for LAIRE .....	275
<i>Play Credits</i> .....	275
<i>LAIRECash</i> .....	275
<i>Brownie Points</i> .....	275

### Other Rules and Regulations 276

Work Duty.....	276
Off Site and Out-of-Game Sleeping.....	276
Parking .....	276
Leaving Early .....	276
Cleaning Up and Checking Out.....	276
Lost and Found.....	276
Camp Safety .....	276
<i>Bear Safety</i> .....	276
<i>Fire Safety</i> .....	277
<i>General Camp Safety</i> .....	277
<i>Personal Care and Safety</i> .....	277

## Appendix A: Master List of Skills ..... 278

## Appendix B: Master List of Spells ..... 283

## Appendix C: Character Boons ..... 289

<i>Gaining and Losing Boons</i> .....	289
<i>Requesting a Boon</i> .....	289
Boon Descriptions.....	290

## Appendix D: Artists Credit Page ..... 294

Artistic Credits .....	294
------------------------	-----







# Chapter 1: Introduction to LAIRE...

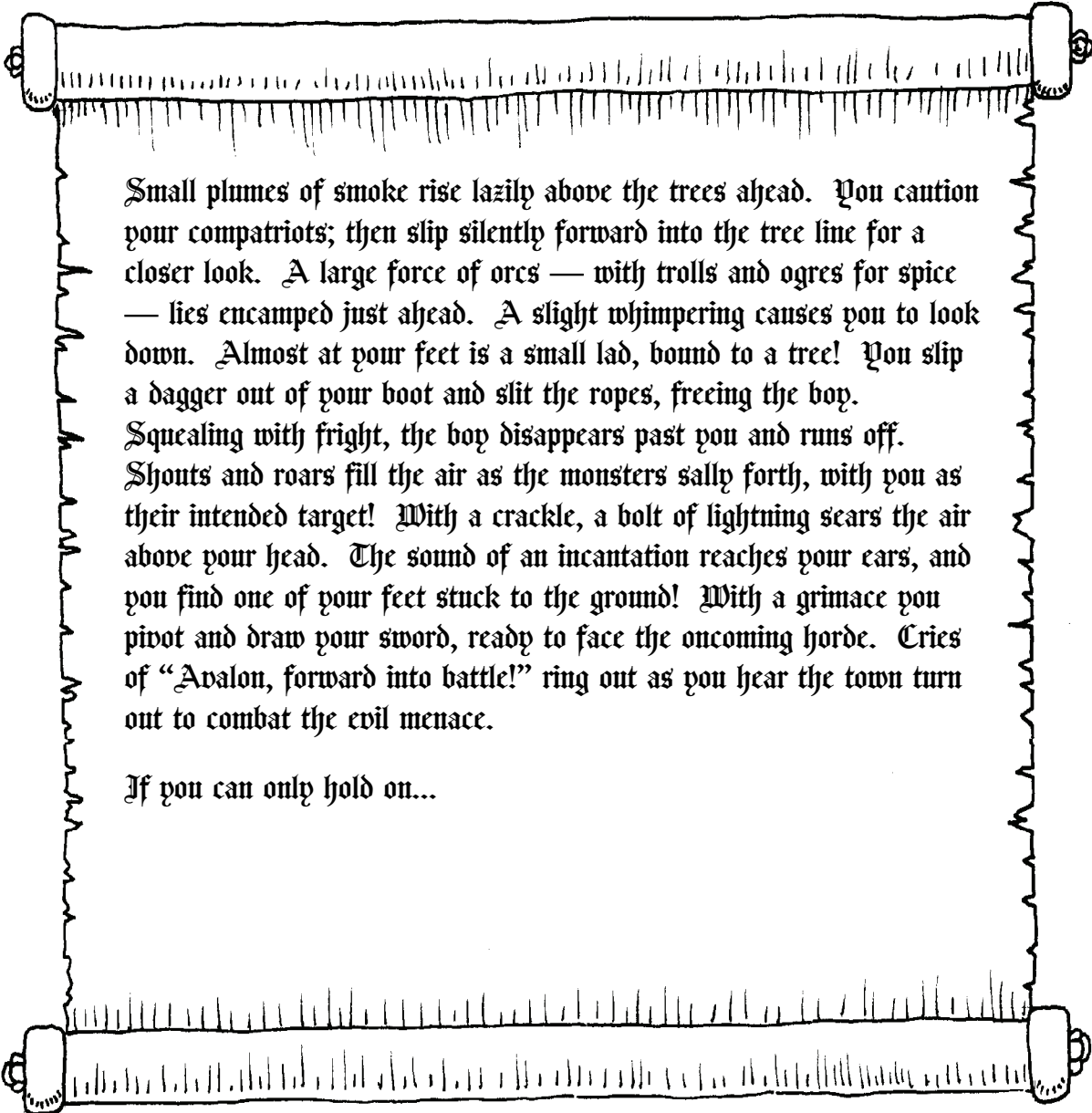

Small plumes of smoke rise lazily above the trees ahead. You caution your compatriots; then slip silently forward into the tree line for a closer look. A large force of orcs — with trolls and ogres for spice — lies encamped just ahead. A slight whimpering causes you to look down. Almost at your feet is a small lad, bound to a tree! You slip a dagger out of your boot and slit the ropes, freeing the boy. Squealing with fright, the boy disappears past you and runs off. Shouts and roars fill the air as the monsters sally forth, with you as their intended target! With a crackle, a bolt of lightning sears the air above your head. The sound of an incantation reaches your ears, and you find one of your feet stuck to the ground! With a grimace you pivot and draw your sword, ready to face the oncoming horde. Cries of “Avalon, forward into battle!” ring out as you hear the town turn out to combat the evil menace.

If you can only hold on...

## Welcome to LAIRE!

This chapter contains an introduction to playing LAIRE. If this is your first Event, you would do well to read this chapter. It covers some frequently asked questions, a sample adventure and some important game rules and concepts you need to get started.

You are required to attend the New Player Training Class, whether you are PC'ing or NPC'ing, which is given on Friday night of every event. If you arrive later in the weekend, we suggest you NPC to get a better idea of how the game is played. During the New Player Training Class you will be introduced to many of the rules of the game, some of which are covered in this chapter. After the class, you will be required to NPC, usually on Friday night, with the class's instructor. LAIRE players are required to give five hours of their time to help the game run every weekend. The majority of the players fulfill this requirement by NPC'ing. Your Friday night NPC duty will fulfill your requirements for your first weekend.

There is much information contained in this rulebook. It will take you a few months to learn all of it. In the meantime, do not be afraid to ask questions or for rules clarifications to the game's marshals or Player Representatives.

Above all else, LAIRE is a game, and the point of the game is to have fun, so remember this while you are playing the game and try not to let the rules overwhelm you or frustrate you. Your fellow players and E-Board are here to help. So welcome to LAIRE and have fun!

## Introduction to LAIRE

### Using This Rulebook

This rulebook is separated into nine sections, each marked with a full-page illustration. However complete this book may be, it is very probable that in your adventures you will encounter characters with special abilities, monsters with unique magical powers, and puzzling mysteries outside the normal bounds of these rules. While the specific situation may not be covered in these rules, all things in the LAIRE world function within the boundaries set forth by these rules. Feel free to question the situation if something is behaving otherwise.

### What is a Live-Action Roleplaying Game

A live-action roleplaying game is very much an adventure story, a play if you will, where each of the players takes up one of the leading roles. However, unlike a play, there is no script to be followed, no cues for the actors, nor any plot line which must be followed. Also, unlike a play, the story does not end when the show closes for the night. The players of a live-action roleplaying game create their own story minute by minute, month by month, perhaps even year by year.

### The Action

In a live-action roleplaying game, you take up the part of a character, performing all of the actions that character performs. There are no dice to be rolled to determine if you can move quietly, no "once, twice, three, shoot" to determine the outcome of a battle, and no chits to move about on a board to show positions. You, the player, must sneak around, fight the battles, and be aware of your surroundings, or it doesn't happen.

When a character attempts to do something that the player cannot (such as swim across a raging river) there are Marshals to determine the outcome. The Marshals supervise the world in which the players' characters live. To help the Marshals decide what is and isn't possible we have these rules, which you are now reading. The

Marshals will use these rules to create a setting within which the fictional characters can adventure. When there is a discrepancy, the Marshals will step in to settle the issue and resolve the situation.

Remember, the more fully you immerse yourself in your character during the game, the more fun you, and those around you, will have with your character. A pirate that wanders around saying, "Dude, arrrrr", and wearing a Disturbed shirt won't have the same effect as a pirate wearing an eye-patch and a bandana who complains about all the "land-lubbers". In short, for the time you are playing your part, do your best to create the image you want others to believe. Simple things like an accent, a trademark item (like a cane), or a behavior quirk can all turn a normal character into a truly memorable one.

### The Fantasy World

Midlantia is a medieval fantasy world where the strange and mysterious are the norm, magic is real, and the forces of darkness are in constant battle with the forces of light. Along with humans, a number of other races can be found. In the magical Mistwood forest lays the Kingdom of the Elves, and the underground strongholds of the Dwarves stretch beneath the Black Hills. All this and more awaits you in the fantastic, living world that is Midlantia.

It is into this land of nobles and commoners, dragons and monsters, danger and adventure that the characters set forth to make their mark. Whether it is a stalwart Human Warrior, a tricky Halfling Rogue, or a stodgy Elven Wizard, the Realms of Midlantia await your presence with open arms and never ending adventure.

### Winning and Losing

Unlike most games, winning and losing is a much more difficult concept in a roleplaying game. The shortest answer would be anyone who plays and has fun has won.

There is no point in LAIRE where the game ends because someone has accomplished their goal. Like in real life, each character will have a set of goals they hope to accomplish, defined solely by that character. One character may hope to accumulate large amounts of money, another may hope to become a Guildmaster, and another may aspire to become a Champion of the High Lord. All of these are acceptable goals and the game is not won or lost for your character until you decide it is.





## A Sample Adventure

This is an example of how the game of LAIRE is played. One encounter in an adventure is described from both an in-game and out-of-game point of view; the in-game view (what is happening between characters) is in normal type, while the out-of-game view (what is really happening between the players) is in italics. This is not an example of ideal in-game behavior; the players make several in-game mistakes (which you can try to spot). It is an example of ideal out-of-game behavior; the players stick to the rules and behave with good sportsmanship.

As you read through these rules, you will learn why the players do what they do in the example, and how their actions are reflected in the game world of LAIRE.

The participants in this encounter are:

Clurd played by *Bruce*  
 Farley played by *Dan*  
 Kahn played by *Mark*  
 Sevin played by *Art*  
 Silvanus played by *Mike*  
 Sindrale played by *Eileen*  
 5 orcs played by *Non-Player Characters*  
 and a *Module Marshal*



### The in-game encounter begins...

The adventurers walk along the trail through the forest. Through a break in the trees they see a clearing. In the clearing there are five creatures; they have green skins, fangs, and noses like pigs. Sevin comments to the others, "They look like orcs. Let's go and slay them." As a dwarf, Sevin wastes little love on orcs.

They approach the clearing. The creatures see the group approach. As the group enters the clearing, one of the creatures steps forward and says, "A hand of us, a hand of them. It will be a fair fight."

A hand? That means five. Farley looks around, and sees that Sindrale is not there. He guesses that she's sneaking through the woods, and quickly begins to speak to cover any sounds she might make. "Greetings, fellow denizens of the woods. Are you guarding this pass? What is your toll?"

The orcs' leader considers. "You don't want to fight? Then give us food. We're hungry."

Sevin wants none of it. "If you want full stomachs, then I'll fill them for you – with steel!" The dwarf rushes forward and attacks.

### Sevin's story

With all his skill and fury, Sevin swings his two-hand warhammer. He strikes a mighty blow on the orc's ribs.

### The out-of-game encounter begins...

*The party walks along a trail through a forest. Through a break in the trees they see a clearing, and they can make out five people standing there. Art asks, "Marshal, what creatures are those?" The Marshal sees that the NPCs are wearing the appropriate make-up and costume for the type of monster they are supposed to be, and responds, "You see what you see." If the NPC's were not wearing the correct costume, the Marshal would have either given a description or told the players out right what they saw.*

*Dan looks around and sees Eileen is missing, and speaks in-game to cover for any sounds she might make moving through the woods. In a situation like this, if Eileen snaps a twig or crunches on a leaf, then the sound occurs in-game. If Dan's voice obscures the sound, then he has also done this in-game.*

### Art's story

*Art runs up to the NPC and swings his foam warhammer in a controlled blow. The NPC is unprepared for the attack and does not parry the blow. Normally, Art's two-hand blunt weapon does 5 points of damage, but Art chooses to use his Critical Attack skill, which doubles a weapon's damage for one strike. When his blow lands, Art calls "Ten Crit". Art has done 10 points of damage to the orc.*

Chapter 1: Introduction

<b>Player Name:</b> Dan Rulebook <b>Character Name:</b> Farelly <b>Race:</b> Common Man <b>Level:</b> 2 <b>Deaths:</b> 0 <b>Marbles:</b> 18W 2B 0R <b>Player Number:</b> 998.1	<b>Body:</b> 14 <b>Power Points:</b> 0 <b>Permanent PP Loss:</b> 0 <b>Spell Singing Points:</b> 0	<b>Sorcerer Ritual Bonus:</b> 0 <b>Sorc. Participant Bon:</b> -2 <b>Faith Points:</b> 0	<b>Last Updated:</b> <b>Last Event's Build:</b> 0 <b>Total Earned:</b> 11 <b>Total Spent:</b> 35 <b>Total Character Build:</b> 36 <b>Unspent:</b> 1 <b>Cameo's</b> 0	
Warrior Basic Career Small Weapon 1-H Edged Florentine Proficiency x 1 1-Handed Edge, Right Disarm x 1 First Aid Stamina x 1	<b>Player Name:</b> Bruce Rulebook <b>Character Name:</b> Clurd <b>Race:</b> Common Man <b>Level:</b> 3 <b>Deaths:</b> 0 <b>Marbles:</b> 17W 3B 0R <b>Player Number:</b> 999.1	<b>Body:</b> 6 <b>Power Points:</b> 33 <b>Permanent PP Loss:</b> 0 <b>Spell Singing Points:</b> 0	<b>Sorcerer Ritual Bonus:</b> 0 <b>Sorc. Participant Bon:</b> -2 <b>Faith Points:</b> 0	<b>Last Updated:</b> <b>Last Event's Build:</b> 0 <b>Total Earned:</b> 21 <b>Total Spent:</b> 46 <b>Total Character Build:</b> 46 <b>Unspent:</b> 0 <b>Cameo's</b> 0
Small Weapon Mage Basic Career SL Auras Rank 2 Healing Rank 2 Thaumaturgy Rank 2 Read Magic Literacy: Common	<b>Player Name:</b> Mark Rulebook <b>Character Name:</b> Kahn <b>Race:</b> Common Man <b>Level:</b> 1 <b>Deaths:</b> 0 <b>Marbles:</b> 19W 1B 0R <b>Player Number:</b> 997.1	<b>Body:</b> 11 <b>Power Points:</b> 5 <b>Permanent PP Loss:</b> 0 <b>Spell Singing Points:</b> 0	<b>Sorcerer Ritual Bonus:</b> 0 <b>Sorc. Participant Bon:</b> -2 <b>Faith Points:</b> 0	<b>Last Updated:</b> <b>Last Event's Build:</b> 0 <b>Total Earned:</b> 6 <b>Total Spent:</b> 31 <b>Total Character Build:</b> 31 <b>Unspent:</b> 0 <b>Cameo's</b> 0
Warrior Basic Career Small Weapon 1-H Edged Disarm x 1 Charms Rank 1 Evaluate Item Stamina x 1	<b>Player Name:</b> Mike Rulebook <b>Character Name:</b> Silvanus <b>Race:</b> Common Man <b>Level:</b> 3 <b>Deaths:</b> 0 <b>Marbles:</b> 17W 3B 0R <b>Player Number:</b> 995.1	<b>Body:</b> 6 <b>Power Points:</b> 33 <b>Permanent PP Loss:</b> 0 <b>Spell Singing Points:</b> 0	<b>Sorcerer Ritual Bonus:</b> 0 <b>Sorc. Participant Bon:</b> -2 <b>Faith Points:</b> 0	<b>Last Updated:</b> <b>Last Event's Build:</b> 0 <b>Total Earned:</b> 21 <b>Total Spent:</b> 42 <b>Total Character Build:</b> 46 <b>Unspent:</b> 4 <b>Cameo's</b> 0
Small Weapon Mage Basic Career SL Auras Rank 2 Pyrotechnics Rank 2 Read Magic Literacy: Common	<b>Player Name:</b> Art Rulebook <b>Character Name:</b> Sevin <b>Race:</b> Mountain Dwarf <b>Level:</b> 2 <b>Deaths:</b> 0 <b>Marbles:</b> 18W 2B 0R <b>Player Number:</b> 996.1	<b>Body:</b> 17 <b>Power Points:</b> 0 <b>Permanent PP Loss:</b> 0 <b>Spell Singing Points:</b> 0	<b>Sorcerer Ritual Bonus:</b> 0 <b>Sorc. Participant Bon:</b> -2 <b>Faith Points:</b> 0	<b>Last Updated:</b> <b>Last Event's Build:</b> 0 <b>Total Earned:</b> 17 <b>Total Spent:</b> 37 <b>Total Character Build:</b> 42 <b>Unspent:</b> 5 <b>Cameo's</b> 0
Warrior Basic Career Small Weapon 1-H Blunt 2-H Blunt Proficiency x 1 2-Handed Blunt Critical Attack x 1 Armor Smith x 2	<b>Player Name:</b> Eileen Rulebook <b>Character Name:</b> Sindrale <b>Race:</b> Common Man <b>Level:</b> 1 <b>Deaths:</b> 0 <b>Marbles:</b> 19W 1B 0R <b>Player Number:</b> 993.1	<b>Body:</b> 7 <b>Power Points:</b> 0 <b>Permanent PP Loss:</b> 0 <b>Spell Singing Points:</b> 0	<b>Sorcerer Ritual Bonus:</b> 0 <b>Sorc. Participant Bon:</b> -2 <b>Faith Points:</b> 0	<b>Last Updated:</b> <b>Last Event's Build:</b> 0 <b>Total Earned:</b> 6 <b>Total Spent:</b> 28 <b>Total Character Build:</b> 31 <b>Unspent:</b> 3 <b>Cameo's</b> 0
Small Weapon 1-H Edged Thrown Weapon Rogue Basic Career SL Disarm Trap Pick Lock Waylay Evaluate Item First Aid	<b>Player Name:</b> Eileen Rulebook <b>Character Name:</b> Sindrale <b>Race:</b> Common Man <b>Level:</b> 1 <b>Deaths:</b> 0 <b>Marbles:</b> 19W 1B 0R <b>Player Number:</b> 993.1	<b>Body:</b> 7 <b>Power Points:</b> 0 <b>Permanent PP Loss:</b> 0 <b>Spell Singing Points:</b> 0	<b>Sorcerer Ritual Bonus:</b> 0 <b>Sorc. Participant Bon:</b> -2 <b>Faith Points:</b> 0	<b>Last Updated:</b> <b>Last Event's Build:</b> 0 <b>Total Earned:</b> 6 <b>Total Spent:</b> 28 <b>Total Character Build:</b> 31 <b>Unspent:</b> 3 <b>Cameo's</b> 0
Marshall Status: Violations:	Marshall Status: Violations:	LAIRE Cash: 0	Brownie: 0 Play Credits: 9	

The orc howls in agony and clutches its side in pain. “You’ll pay for that, human!”

Sevin’s face contorts in anger. “Human? You’ll pay for that insult, orc!”

*Roleplaying wounds in the middle of a combat is difficult to do; people tend to keep swinging at each other no matter how often their characters are hit. However, when Art sees the NPC roleplaying the orc’s wounds, he is encouraged to roleplay the damage to his own character.*

Distracted by his rage, Sevin allows two of the orc’s blows to strike him, but the orc only succeeds in denting the dwarf’s armor. “You’ll pay for that too, orc! It took me a long time to polish that armor!”

*The NPC strikes Art with a two-handed foam sword. When the sword hits, the NPC calls “3 Damage”, which is the normal damage done by such a weapon. Art roleplays the damage to his character’s armor. Armor Points absorb damage before Body Points do; Art’s character had 15 Armor Points, so Sevin is still unwounded. Art has 9 Armor Points left.*

Their comrades around them are fighting, but Sevin and the orc leader concentrate on each other. Each swings their weapons at the other, and each time their opponent parries the blow. Finally Sevin feints and gets under the orc’s guard. The dwarf manages to strike the orc twice - and the orc falls to the ground, bleeding to death.

*Art has practiced using his foam weapon and he swings it carefully. When he feints and has a chance to strike the NPC, each of his two blows is a 90-degree swing, hard enough so the NPC can feel the blow but not hard enough to actually hurt. Each time the weapon hits, Art calls “5 Damage”. The NPC’s Body Points are exhausted, so the player lies down on the ground and begins his Death Count, starting at Bleeding to Death.*

Sevin takes no chances. Even when his opponent is lying motionless before him he wants to make certain that the orc is dead. He takes his warhammer in a mighty two-hand blow and crushes the orc’s chest.

*Art holds the end of his warhammer against the NPC’s chest and says, “One killing blow, two killing blow, three killing blow, 5 Damage.” He paces the phrase so it takes at least 3 seconds to say; at the end of the phrase he includes the amount of damage normally done by his weapon. The NPC roleplays the death with a gurgling death rattle.*

Sevin looks up from his defeated opponent to see if any of his comrades needs help. But the battle is over; he sees his help is not needed. Now his concern is for his armor. He moves to one side of the clearing to be out of the way, and begins to reset it.

*Art’s character has damaged armor and he wants to reset it before the next encounter. Art tells the Marshal that he is resetting his armor and the Marshal notes the time that Art begins. Art begins to use this time by getting his tags from his pocket and adjusting them from the combat.*

*The NPC who played the orc leader lies on the ground for five minutes, enough time to be searched if the players chose to do so. After that, the NPC gets up, puts on a white headband, and walks over to Art for the tag exchange. Art gives the NPC a Critical Attack tag and 3 Armor Points.*

### Kahn’s story

The orc in front of Kahn is holding a longsword and a dagger, but Kahn only has one longsword. Kahn thinks this is an unfair advantage. When Sevin attacks the orc leader, Kahn incants, “I command you to fumble,” and hits his opponent with the spell. The orc drops the sword it was holding in its right hand.

Kahn runs forward. The orc has only a second to make a decision: should it bend down to pick up its fallen sword, or just shift the dagger it is holding to its right hand? The orc decides to switch hands, and then there is no more time, for Kahn is swinging at it.

The orc attempts to parry Kahn’s blow, but Kahn still has one more trick up his sleeve. With a deft maneuver, Kahn makes a little spiraling twist with his sword and disarms the orc.

### Mark’s story

*Mark holds a foam longsword in his left hand and a spell beanbag in his right hand. When the combat begins, he says the verbal for the Fumble spell and throws the beanbag at his opponent. The beanbag hits, and Mark says, “Your right hand” to inform the NPC which hand is affected by the spell.*

*The NPC playing this orc is new, and is not sure whether the benefit in swinging two weapons outweighs the risk that Mark might get in one or two blows while the NPC picks up the sword. In general, swinging two weapons is so much more potent than using one that the risk is worth it. The NPC does not know this, and decides the other way.*

*Mark hits the NPC’s dagger with his own sword and says, “Disarm.” The NPC is unsure, and asks, “Out-of-game: Does that work if you just hit my weapon?” Mark pauses in his attack, since he does not want to make an in-game attack while answering an out-of-game question. Mark says “Yes.” The NPC drops the remaining dagger, and the combat continues.*

The orc is now completely disarmed. It hesitates, then turns and runs. With a yell of triumph, Kahn runs after it. They rush out of the clearing and down a forest trail, but the orc is faster than Kahn and escapes.

*The NPC tries to run away and Mark runs after. When they reach the edge of the clearing, the Marshal calls out, "Mark, the orc gets away." The NPC puts on a white headband, while Mark, disappointed, walks back to the center of the clearing.*

Kahn returns to the clearing, but the combat is over.

*Mark asks the Marshal why the orc escaped. The Marshal answers, "Out-of-game that trail is not safe for combat and the players can't go running on it."*

*The NPC asks the Marshal to confirm that the Disarm skill works when you strike the weapon. The Marshal answers that Disarm will work on the weapon if it is a one-hand weapon; Disarm only works on a two-hand weapon if the "disarmer" hits the opponent in the arm.*

*The NPC is a little embarrassed, since he thinks it may sound as if he was accusing Mark of cheating. Both the Marshal and Mark assure the NPC that it is always okay to ask and confirm. During this discussion Mark gives a Power Point tag (for the Fumble spell) and a Disarm tag to the NPC. Mark also takes the opportunity to briefly advise the NPC about picking up a dropped weapon. Mark concludes the out-of-game conversation and gets back in-game.*

**Silvanus' story**

As the party had approached the orcs, Silvanus noticed that one of them did not have any weapons. Silvanus watched that orc carefully, for that orc might be a shaman of an orc tribe – a spellcaster like himself.

When the battle begins, Silvanus moves behind Farley. As an unarmed spellcaster, Silvanus feels his role in combat is to aid the fighters from behind. Since Farley is being attacked by two orcs, he is in need of the most aid.

**Mike's story**

*The NPC that Mike is watching does not have any weapons, but the NPC is holding a handful of spell packets. However, spell packets are not in-game, and Mike does not draw any in-game conclusions from them.*

The gray yet actinic force of a spell rushes past Farley, cast by the orc that Silvanus identified as the shaman. Silvanus knows that the orc spellcaster must be neutralized if Farley is to have any chance at all.

Silvanus prepares a Fireball spell by incanting, "I summon forth an eldritch fireball," and steps out from behind Farley to cast it. The spell strikes the orc spellcaster, but the shaman's body glows with a brief flash of light; the orc had a defensive spell.

The shaman recites, "I call upon darkness to harm," and throws a Harm spell that strikes Silvanus' body. Such a spell would be fatal to him, so Silvanus invokes a Negation to neutralize the spell.

Silvanus has a split-second decision to make. Should he take the time out to cast another Negation spell on himself, or should he press the attack? He sees that Farley is having difficulty with two opponents, and decides to stay on the offense. He prepares to cast another Fireball spell at the shaman by reciting, "I summon up an eldritch fireball," but this is not the correct incantation, and the spell has no effect.

Silvanus gets ready to throw another spell and begins to recite, "I summon forth an..." But the shaman is able to recite "I create a magical seal that will bind," and strikes Silvanus with the spell before Silvanus can finish his incantation. Silvanus has no way to resist the Bind spell. His legs are drawn together, his feet are stuck to the ground, and his arms are glued to his sides. He cannot cast a spell or run away.

*The NPC playing the orc spellcaster recites a spell verbal and throws a beanbag at Dan. Mike does not make out what the NPC says, but it does not matter; the beanbag strikes Dan in the head, which is not a legal target for spells or weapon attacks. The NPC says, "No effect," to acknowledge that the spell does nothing to Dan's character.*

*Mike recites the incantation and throws a beanbag. When it hits the NPC, Mike states the damage that the spell does: "Sixteen Magic Fire". However, the NPC calls, "Negation", which means the NPC chose to invoke a Negation latent spell defense.*

*The NPC says the verbal for a Harm spell and throws a spell packet. When the beanbag hits Mike, the NPC says, "Six Body," which is more Body Points than Mike's character has. Mike has previously cast a Negation spell on himself, and he invokes it now by saying, "Negation."*

*Mike says, "I summon up an eldritch fireball," and throws a spell packet. As the beanbag leaves his hand, he realizes he made a mistake in the verbal; the correct phrase is "I summon forth an eldritch fireball". He calls out "No effect" to acknowledge to the NPC that he made a mistake.*

*The NPC says the verbal for the Bind spell and throws another beanbag. Mike had gotten as far as "I summon forth an..." when the beanbag hits him, which means that he cannot finish casting the spell. Mike puts his arms and legs together, acting out the effects of the spell.*



The orc shaman laughs, and walks toward Silvanus. The orc passes close enough to Farley to cast a spell at him. The orc recites, "I call upon darkness to harm," and hurls the spell at Farley. Then the orc moves on.

*The NPC says the verbal for a Harm spell and tosses a beanbag at Dan. When the beanbag hits him, the NPC says, "Six Body".*

A spell flashes by, almost distracting him. However, he sees that Silvanus is dealing with the spellcaster, and quickly returns his attention to his opponents.

*A spell packet beanbag hits Dan in the head. He hears the words, "no effect," and wastes no more time on the matter.*

The enemy spellcaster will soon come so close to Silvanus that a spell cannot miss. Silvanus knows that he is doomed. He might have freed himself if he had a Giant Strength spell in reserve, but he does not. The shaman moves closer.

*The NPC says the verbal for a Harm spell and tosses a beanbag at Dan. When the beanbag hits him, the NPC says, "Six Body".*

The two orcs maneuver to get around him, and he steps back so they cannot do so. If he keeps retreating, he knows that eventually he will be forced into the woods and he will not be able to step back anymore without tripping. He is well-armored, and has Armor and Stamina spells to defend him, so he makes a quick decision.

*The Armor spell adds 3 Armor Points; these are the first Armor Points lost in combat. The Stamina spell adds 3 Body Points; these are the first Body Points lost when the character takes Body Point damage.*

Then Clurd reads from a scroll, "I pierce the veil of force and energy to dispel magic." The spell strikes Silvanus, destroying the effects of the Bind spell.

*Bruce reads the verbal for Dispel Magic and throws a spell packet. When the beanbag hits Mike, he adds, "The Bind is dispelled," so that Mike knows he is free.*

Ignoring one of his opponents, he quickly moves forward and strikes one of the orcs with both his weapons. He has practiced more with his right arm than with his left, and so the blows with the right hand weapon inflict the more grievous harm.

*Dan's character has learned one Weapon Proficiency with One-Hand Edged weapons with his right hand; a one-hand weapon normally does 2 points of damage, but with his Weapon Proficiency Farley can do 3 points of damage. When Dan rushes forward to attack a single NPC, he manages to strike the NPC once with both weapons. He calls "Three Damage", when his right-hand sword hits; "One Damage" when his left-hand dagger hits.*

Before the shaman can react, Silvanus cries out, "I summon forth an eldritch fireball," and hurls a spell at the orc. The orc howls in agony and collapses.

*One last time, Mike says the verbal for the Fireball spell and throws a beanbag; when it hits Mike adds, "Sixteen Magic Fire". The NPC roleplays the burning effects of the spell and lies down.*

Silvanus takes no chances. He takes a scroll from his pouch and reads, "With pure magic I cast a giant strength", and casts the spell upon himself. He then rushes up to the fallen spellcaster and, after a moment's hesitation, breaks the orc's neck invoking his *Giant Strength* spell.

*Mike places his hand on the NPC's torso, and recites, "One killing blow, two killing blow, three killing blow, three damage." In order to deliver a Killing Blow with his bare hands, Mike must have a Strength Bonus of +3 and therefore invokes his latent Giant Strength spell.*

But the orc that Farley ignored is fast as well. As Farley turns his back, the orc attacks, and strikes Farley three times.

*The orc NPC calls "Two Damage" each of the three times he strikes a blow. Farley's Armor spell defense is gone, and 3 points of damage have been done to Farley's armor.*

Silvanus looks around to see how his comrades are faring, but the battle is over.

*Mike has cast four Fireball spells including two botches, but only the successfully cast spells cost Mike any Power Points. He gives tags worth 8 Power Points to the NPC who played the spellcaster.*

Farley quickly considers. He thinks he hurt his opponent more than he himself was hurt. He decides to try the same strategy again. This time he decides to attack the orc who was fast enough to harm him.

### Farley's story

Farley can fight with two weapons at once, and he is armed with a longsword and a dagger. However, he faces two orcs in combat, and so the odds are not in his favor. He knows he should not allow the two orcs to get on either side of him, for it is almost impossible for a fighter to defend from that position, even if they have two weapons.

### Dan's story

*Dan's character has the Florentine skill, which allows him to fight with two weapons at once. He wields a foam single hand sword and a dagger.*

But this time the orc behind him says, "I summon forth an eldritch flare," and throws a magic spell. A small blast of fire strikes Farley. At the same time, the Harm spell cast by the shaman hits Farley. This distracts Farley so much that he does not hit the orc he chose to attack, but that orc hits him twice.

*The orc NPC says the spell verbal for a Flare spell, and says "Eight Magic Fire" when the beanbag strikes Dan. Dan had seen the beanbag in the NPC's hand, but since spell packets are out-of-game he had ignored it. The other orc NPC says, "Two Damage" each time he strikes Dan.*

*Dan has been hit by so many spells and swords that he's lost track. He says, "Hold! Wait a minute, please." Dan performs the arithmetic as quickly as he can.*

*Dan's character has taken a grand total of 18 points of normal damage, and 6 point of direct Body Point damage; his Armor Points are gone; the extra Body Points granted by the Stamina spell are also gone; he has 6 Body Points left. He tells the NPCs, "I'm still up. Let's go on."*

Farley knows he is in trouble. An orc who can cast spells is always the more dangerous opponent, so he rushes at that orc again. He strikes at that orc with both weapons and hits both times, but his opponents are ready for him. He is hit twice by the orc he faces, and twice again by the orc behind him.

*Again Dan hits an orc, calling "Three Damage, One Damage" as his weapons hit. But as he does so the NPC in front hits him two times with a foam sword, calling "Two damage" twice. The NPC behind him calls "Two Damage" twice as the NPC's weapon hits two times.*

The orc that Farley hit falls down. But Farley is so badly wounded that he falls to the ground, bleeding to death.

*Dan has done a total of 10 points of damage to one of the orc NPCs and that NPC lies down. But another 8 Points of Damage have been done to his character's Body Points, and so Dan lies down. Farley is now at -1 Body Points (a character cannot have less than -1 Body Points).*

One of the orcs remains standing. As it contemplates Farley's bleeding body, Sindrale rushes up behind the orc and strikes it in the back of the head. The orc falls down unconscious.

*Eileen comes up behind the remaining orc NPC and lightly taps the player between the shoulders, calling "Waylay One". The NPC has been surprised and so the NPC has been Waylaid. The NPC takes 1 point of damage and lies down, feigning unconsciousness.*

### Clurd's story

Clurd stands well behind the other adventurers as they fight. He does not get involved in the battle. This is how the other adventurers would have it, because Clurd is the group's healer and source for their defensive spells. He only got involved in the battle to the extent of casting a Dispel Magic from a distance when Silvanus needed it.

When Clurd sees that all the orcs have been defeated, he rushes to Farley's side and begins to administer first aid.

After bandaging Farley's wounds, Clurd knows that Farley will wake up in about five minutes. He decides not to wait that long. He recites, "I draw upon the earth to heal this person," and touches Farley, who regains consciousness.

Clurd gestures at Sevin, who is repairing his armor. He says, "I can't repair your armor for you, and Sevin is busy, but at least I can restore the spells you've lost." He incants, "I weave an aura of armor. I weave an aura of stamina," to cast an Armor spell and a Stamina spell on Farley.

### Bruce's story

*Bruce goes to Dan, places one hand on Dan's torso, and calls "First Aid". He begins to count off the seconds silently, since the skill of First Aid takes 60 seconds to apply. After the minute is up, Dan's character is at 0 Body Points, and will wake up in 5 minutes at 1 Body Point.*

*Bruce says the verbal for Heal Person, touches Dan with his spell packet, and says, "You are healed for 9 Body Points." A spell packet is still necessary, even though Bruce can make direct physical contact with Dan and Dan is not trying to dodge the spell. He takes the tags for 3 Power Points, writes on the back, "9 Body Points," signs his name, and gives them to Dan.*

*Bruce says the Armor and Stamina spell verbals. He touches Dan each time he recites a verbal. He takes the tags for three more power-points and writes on the back, "Armor Spell", "Stamina Spell", signs his name on each tag, and gives them to Dan.*

*No one ever asks Bruce for the scroll he expended to cast the Dispel Magic, so he tears off the Power Points and puts them in his pouch.*

*As he does so, the two NPCs that Dan fought put on white headbands and ask for tags. Dan gives them all the Body Point tags, Armor Point tags, and tags for the Armor and Stamina spells that were used up during the battle.*

**Sindrale's story**

The combat is over, but Sindrale's job is not yet done. First, she inspects the bodies of the orcs. She makes sure that all four are dead, and she searches the bodies for treasure. Sindrale finds a silver piece on two of the orcs.

Sindrale gives the two silver pieces to Clurd, who normally holds the group's treasure until the end of their expeditions. She then searches the clearing. The orcs' campsite is easy to spot. She looks through their old clothes and bedding and finds nothing.

There is a brief gust of wind, and some leaves on the ground blow away. Sindrale sees that a box has been covered by a mound of leaves. Carefully, she brushes the leaves away.

Sindrale informs the rest of the group what she has found. She advises them to stay at least ten paces away from her as she investigates the box. If there is an explosive trap in the box, she does not want anyone else to be hurt.

The box has a lock on it. Sindrale examines the lock, pulls out her toolkit, and selects a lockpick. Deftly she picks the padlock, removes it from the box, and sets it aside.

**Eileen's story**

*Eileen goes to each NPC lying on the ground. She touches the torso of each with her dagger and says, "One killing blow, two killing blow, three killing blow, One Damage." Then she says to the NPC, "I search you." None of the NPCs chooses a complete search. Two of the NPCs hand her a silver piece each; the other two say, "You find nothing." After the NPCs have been searched, they get up, put on white headbands, and collect tags from the players.*

*Eileen looks around the camp and sees the NPC's campsite. She asks, "Which of this is in-game?" An NPC answers, "Everything on that blanket is out-of-game. Everything else is in-game." Eileen had already guessed that, since all that was on the blanket were some modern-period shoes and some soft-drink bottles, but it does not hurt to make sure.*

*The wind and the moving leaves are all considered to be in-game. If there had been no breeze and Eileen had never searched that particular pile of leaves, she might never have found the box.*

*As Eileen examines the box, the Marshal stands nearby and watches her. The Marshal will answer any of her out-of-game questions and inform her of any in-game consequences of her actions.*

*Eileen's character has the Pick Locks skill. Without it, she could not even attempt to pick the lock in-game. After she picks the lock, she gives it to the Marshal (the easy-to-pick locks are hard to find; players are not allowed to keep them).*

Just because the box had a lock does not prove that there is no trap inside; Sindrale remains cautious. She takes a small, flat piece of wood from her toolkit. Gently she raises the lid of the box by a small fraction of an inch, and inserts the wood so that the lid is propped open.

Sindrale lies on the ground with her face next to the lid and peers inside. She cannot see much. She takes a small mirror on the end of a stick from her toolkit, sticks it into the box, and examines the insides.

She sees that the box is indeed trapped, but she also sees the mechanism. With a small pair of tweezers from her toolkit, she disarms the mechanism.

Slowly Sindrale raises the lid of the box. Nothing happens. She opens the box all the way, allowing the lid to fall back. She looks inside the box and sees a piece of paper; it looks like a magic scroll.

Sindrale says, "Clurd, I found a scroll." She takes it out of the box. There is a sudden explosion, and the front of Sindrale's armor is scorched.

Sindrale is annoyed. She examines the remains of the trap, determined not to be caught by such a trick again. Among the ruins of the trap she sees three gems. Quickly she picks them up. She says, "Clurd, look! I found three gems."

*And the adventure continues...*

*Eileen's toolkit contains a number of tools that she purchased herself out-of-game; she got approval from a Rogue Marshal to place these items in-game, in exchange for paying an in-game price for some of her more exotic tools. Eileen's character also has the Disarm Traps skill; without it, she could not even attempt to disarm the trap.*

*The "mirror at the end of the stick" is a small dental mirror.*

*Eileen sees a string going from the top of the box to the bottom. Since all traps must be disarmed non-destructively, she cannot cut the string. However, she sees that the string is attached to the inside lid of the box with a piece of tape. She uses the tweezers to pull the tape off the lid.*

*Eileen's character does not have the Read Magic skill, so she cannot identify the scroll in-game. However, small sheets of fine vellum with fancy or ornate writing are usually scrolls, so Eileen may come to this conclusion in-game.*

*The scroll was attached to a party popper, which went off when Eileen pulled the scroll from the box. The Marshal says, "You take 5 points of damage from the trap." After spending time adjusting her armor, Eileen gives 3 Armor Points to the Marshal.*

*Eileen asks, "Marshal, are the gems still intact after the trap went off?" The Marshal answers, "Yes."*

## Basic Game Rules and Concepts

### The First Rule

**If a skill, spell or other rule does not explicitly state you can do something, then you cannot do it.** For example, the *Giant Strength* spell does not say you can use it to leap greater distances, therefore, no matter how creative you may be in trying; you cannot leap with a *Giant Strength* spell. Another example, the Slay skill says nothing about being used to break an object such as a door. During game play your character wants to get into a room behind a closed door. You cannot use one of your purchases of the Slay skill to break down the door.

### Characters and Players

You are a player and your character is the role you take up in the LAIRE game world. Characters are anything played by a player in the game. Any PC or NPC is a character; Orcs, Goblins, Zombies, Dwarves, etc are all characters. Throughout this rulebook these two words are used and they are **not** interchangeable. Be careful when you read this rulebook, many of the rules change their meaning if you exchange these two game terms.

### Tag Cycles and Using Skills

**If you do not play in a Tag Cycle you cannot use tags from that Tag Cycle.** This rule applies to PCs as well as NPCs.

### Rounding Rules

From time to time a player may have to round a number. Unless otherwise stated, the player should round any remainder in their favor with a minimum of 1.

### Losing Permanent Pool Points or Body Points

No character can ever be forced by any charm effect to use a skill or ability, cast a spell or a ritual that will expend permanent pool points – Power Points, Elemental Pool Points, etc. – or permanent Body Points. If the character is made to do so, the attempt fails and nothing is lost.

### Rule Conflicts

Some rules, skills, spells, rituals, etc. conflict with a more general rule or another skill, spell, ritual, etc. **To determine how these rules interact, follow the rule with the most specific information.** For example, the general rule is, a skill is used if a defense is called for it. However, many faith skills state that only a magical defense, such as an *Invulnerability* spell will cause the faith skill to be expended. Finally, the Destroy Undead skill is not used if an *Invulnerability* spell is called.

## The Hold Rule

**The most important combat rule is the Hold Rule, which can be invoked by any player at any time.**

### What Happens When You Call a Hold

When someone calls the word “Hold,” you should stop what you are doing immediately, and stay exactly where you are. Do not leave the spot you are standing on; players who move without good reason during a Hold should be reported to a Marshal. Do not have any conversation during a Hold, in-game or out-of-game, unless it relates to the specific reason why the Hold was called.

### How to Call a Hold

To call a Hold, shout “Hold” as loud as you can. If you hear the cry of “Hold” you should repeat it at once, and then stop any action you are involved in. In combat situations, be sure your opponent has recognized the Hold before dropping your guard.

When the reason for a Hold has been resolved, the player who called the Hold or a Marshal should call “Three, two, one... LAY ON”. The game then resumes from where it left off.

### When to Call a Hold

The main reason to call a Hold is for a safety reason. Safety reasons include:

- a personal injury;
- a combat rules violation, such as:
- another player strikes you in the head or groin,
- a player is striking you too hard;
- you see something that may endanger you or other players:
- rocky or dangerous terrain,
- broken glass on the ground,
- a pit or a hole,
- a child or a non-LAIRE member entering the play area,
- spotting broken weapons or armor,
- a player entering an out-of-game area.

You can also call a Hold for a rules related reason, such as clarifying the effects of a spell. This is mildly discouraged, since there is nothing more distracting during a battle than a stream of Hold’s for trivial reasons. If there is a rules problem in the middle of a battle, try to work it out quickly without calling a Hold. It is common courtesy for players not involved in the clarification to pause and wait for those involved to be done before continuing. Be aware of your surroundings and what the other players are doing.

### What is not allowed during a Hold

Players may not call a Hold for personal convenience or to perform any out-of-game activity that has an affect in-game. For example, it is illegal to call a Hold in order to gather spell packets or arrows. If a Hold is called for another reason, you are allowed to gather spell packets but you must be back in the place where you started when the LAY ON is called. You may not gather thrown weapons or arrows since these items are in-game.

**No in-game conversation, discussion of tactics, or other talking should occur during a Hold.** Only the person who called the Hold, the Marshal, and any subject of the Hold should speak while it is in effect. This will shorten the Hold, and keep the flow of the game going. Also, if the Hold was called because of safety reasons or for a Marshal to give an in-game description or other instructions, you cannot hear it if you are talking. **This cannot be stressed enough, when you hear a Hold called, be quiet!**

Also, you may not call a Hold to compensate out-of-game for in-game challenges. If you are out of breath, stumble, or drop your sword you may not call a Hold to catch your breath, regain your balance or pick up your sword. You may consult a copy of the rules or an out-of-game copy of the spell verbals during a Hold.

Players who call unnecessary Hold’s will be cautioned. If the player continues to call unnecessary Hold’s, they will be disciplined.



### ***The Word Hold In-game***

You are encouraged to use “period sounding” speech, but a cry of “Hold varlet! I wish to smite thee” is a bad idea. All those around you will hear and repeat the “Hold” and will ignore the rest of your sentence. Therefore, you should not yell the words “Hold” or “Halt” at all, and you should be cautious about beginning any sentence with the word “Hold.” Instead, use the word “Stop”, or “Keep the line” instead of “Hold the line”.

## **Weapons, Magic and Taking Damage**

Combat is a large part of our game. Below is a very basic overview of how combat works and how to take damage. For a more detailed description of the rules on combat at LAIRE please see the chapter on combat.

### ***Striking With a Weapon***

You must swing your weapon at moderate speed with moderate force. If you do not have enough time to call damage between each of your swings, then you are swinging too quickly.

A swing should cover no more than 180 degrees, and no less than a combined 45 degrees with your arm and 90 degrees with your wrist. A “windmill” swing is not allowed. If you swing too hard, you will be warned for excessive force. Repeated offences will result in a combat violation, which will result in your removal from combat for the rest of the Event and a required attendance at a re-education class before you are allowed into combat again.

You must precede thrusting attacks by drawing back for each strike. Nobody ever pierced a breastplate by going poke, poke, poke with their sword.

Adjust yourself to your opponent. Big brawny men in 40 pounds of plate mail are less likely to feel the blow of a foam sword than someone weighing 120 pounds wearing a few wisps of cloth. If someone is striking you too hard, tell them to ease off. The reverse is true as well; if someone is striking you too softly for you to feel through your armor, let them know.

### ***Calling Damage***

When you strike with a weapon, you should call out the damage inflicted by that weapon. The damage done by a weapon must be followed by some modifier; normally this is the word “damage”. For example, if you are wielding a Two-Hand Edged weapon and you have no special combat bonuses, you would call “Three Damage” when you strike an opponent with your weapon.

Even if your attack does not make contact, you may still want to call damage with every swing. You never know if your opponent is going to make an error and your attack may get through unexpectedly. If your attack lands and you do not call damage properly, your opponent does not have to take the damage.

Calling damage is out-of-game. If your character is under the effect of some force that causes the character to be silent, you must still call damage with each blow.

When swinging special weapon attacks, such as the Slay or Disarm skill, you should give your opponent a moment to respond to the attack by either taking the effect or calling a defense. It is a good practice to acknowledge the attack by looking at your opponent and saying “Got it,” or some other similar phrase. This is not required but it will help to alleviate confusion. If you have multiple purchases of a specialty attack you may chain them together, attacking your

opponent quickly. However, if your opponent ever calls more defenses, takes the effect, or any combination of these than you have current uses of the skill then you will receive a rules violation. For example, John is playing a warrior and has two purchases of the Slay skill. During a fight he hits his opponent four times calling “Slay” each time. The defending character calls “Invulnerability, Slay Parry, Slay Parry, Ritual of Defense”. John is in violation of the rules, he only had two Slays. Another example, John strikes his opponent three times calling “Slay” each time. The defending character calls “Invulnerability, Dodge” then falls down. John is in violation of the rules, he only has two Slays.

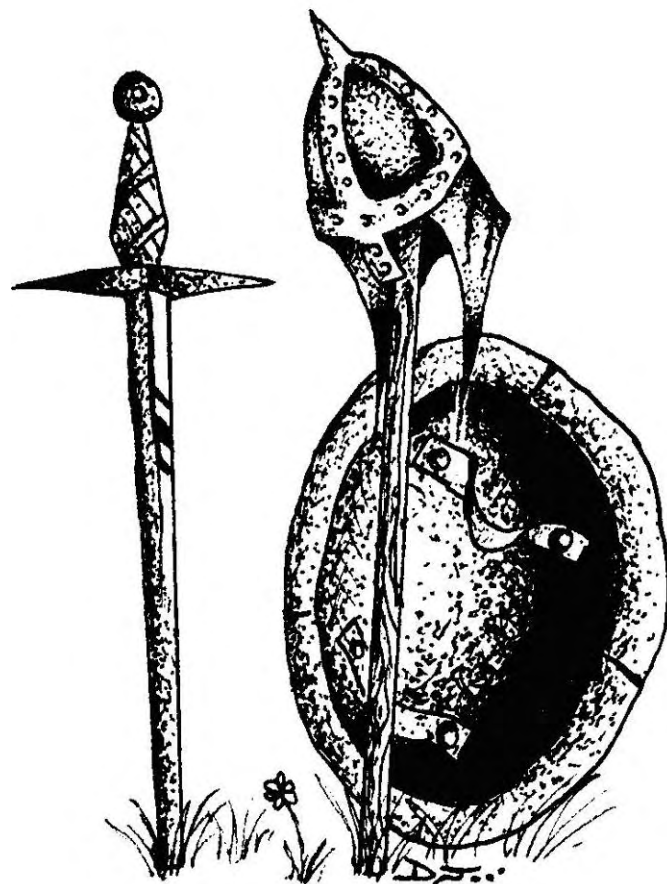

### ***Additions to Normal Damage***

You should add any Damage Bonuses you have to the Base Weapon Damage of the weapon you are wielding. For example, if you are striking with a regular long sword you would call “Two Damage” with each blow; if you had two purchases of the Weapon Proficiency skill giving you a +2 Damage Bonus with the long sword then you would call “Four Damage” with each blow.

If your character has the Florentine or Master Florentine skill, then you must call damage with each weapon for each strike. You cannot add up the damage of both weapons in a single blow. Call the damage for each of your weapons clearly; these skills do *not* allow you to swing your weapons twice as fast.

You should only call the damage that your character normally does. If you are aware that a particular attack does extra damage to a type

of monster, let the NPC do any special calculations. For instance, Arturis the Warrior carries the legendary Lightning Blade. He knows that the Gelatin Golem he is fighting takes double damage from electrical attacks; still, he only calls “Two Lightning” when attacking and lets the Gelatin Golem’s player double the damage.

### ***When You Do Not Call Full Damage***

You are allowed to do less damage than your maximum. If your character can call “Six Damage” because you are wielding a two-hand blunt weapon and you have a +3 Damage Bonus, you can choose to call “One Damage” instead. However, if the weapon has any special modifiers, you must state the appropriate modifier for that weapon. For example, if you have a +2 magic long sword and two purchases of the Weapon Proficiency skill, you can call “One Magic” instead of “Six Magic,” but you *must* include the word “magic”.

You do not call damage with certain special attacks. If you are making one of these special attacks, you do not call damage along with the special attack. For example, assume that you deal 5 points of damage with your weapon and have one purchase of the Slay skill. If you hit a player and call “Five Damage,” you cannot use a Slay as well.

### ***Taking Damage***

You are responsible for keeping track of the damage that has been done to your character. As you are damaged, you must keep a running tally of how many Armor Points and Body Points you have, and to subtract damage from this total as you are struck. Under normal circumstances, you first subtract the damage from your Armor Points; when your Armor Points are gone, you subtract the damage from your Body Points. When your Body Points reach zero or below, lie down; your character is either Unconscious or Bleeding to Death. Please see later in this chapter for more information on death and dying.

**If no marshal is present, the player who is taking the damage, not the one inflicting it, has the final say on how much damage has been taken.** The marshal has final say on whether an attack is successful or not. It is sometimes necessary to make a judgment call when you are trying to decide whether legal contact was made in combat. If you feel a solid blow, then you should take the damage. If someone barely touches you with their weapon, then you do not have to take the damage. If someone is consistently hitting you too softly, let them know. If someone insists they hit you, but you did not feel it due to thick clothing or heavy armor, take the damage honorably, and request that they strike with a little more force.

If you deliberately block or deflect a weapon, then it does not do damage, nor do weapons that strike your shield. However, normal objects do not protect you against a weapon attack. If you happen to have a sheathed sword and someone hits you on that sheath, the blow is not parried; if you feel the blow you should take the damage. It is illegal to deliberately block an attack with a body part that is not a legal target.

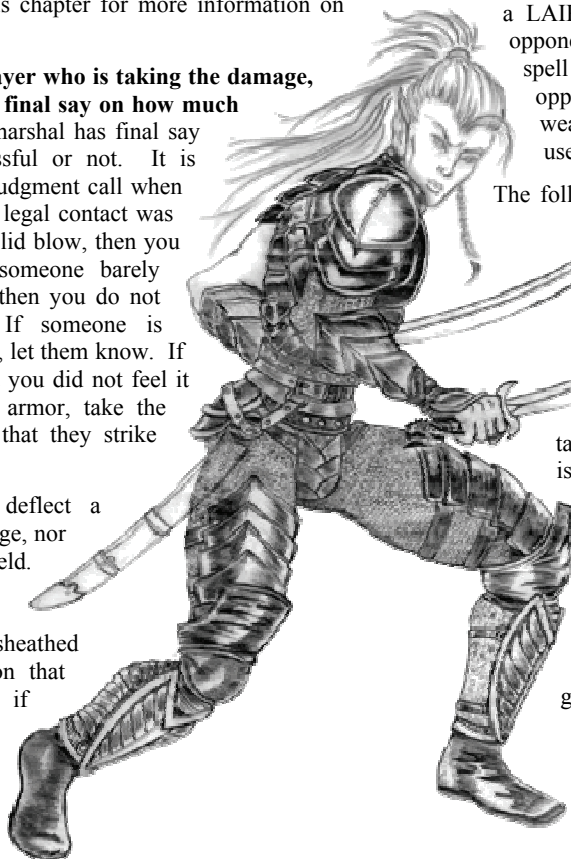

If you think a player is not taking their damage fairly, then you should report them to a Marshal. Be sure to ask the player about how much damage they thought they took; remember that there are monsters that are immune to the attacks of some weapons. Players who are repeatedly cautioned for not taking damage will be disciplined.

### ***Illegal Combat Maneuvers***

The following combat maneuvers are illegal in the LAIRE rules system:

- Trapping a weapon with any body part.
- Trapping or pinning a weapon with another weapon or against any object at any time. This includes standing on a weapon or roleplaying standing on a weapon.
- Charging, or running at an opponent so fast as to force them to retreat for fear of injury. It is acceptable to run up to an opponent so long as you stop in front of them and do not cause them to retreat.
- Crouching down behind a shield so that you cannot be struck anywhere but in the head; this is called “turtling.” In real combat, a turtled individual could be physically pushed over, but since no physical contact is allowed in combat, neither is turtling. Standing in a corner with your shield protecting you is not turtling; as long as you present a legal target for an opponent while your shield is in front of you, you are not turtling.
- Fighting in such a way that an illegal combat target becomes highly vulnerable to being struck.

### ***Legal Contact in Combat***

In combat, the only physical contact allowed between players is using a LAIRE-authorized weapon. You may not touch an opponent in combat with your hands, not even to cast a spell or administer a poison. You may not grab an opponent’s weapon with your hand. A shield is not a weapon; you can use it to parry blows, but you cannot use it to pin a weapon or strike another player.

The following areas of the body may not be struck by a weapon at all: the head, the neck, and the groin. This is a safety issue; if you should accidentally strike a player in one of those areas then they take no damage, and you may receive a warning. Wrists and hands are “semi-legal” targets; it is not a weapons violation to hit those areas, but the target takes no damage as a result. Though the chest is a legal strike area, please exercise extra caution when fighting women.

Apart from the areas mentioned above, all other parts of the body, including the soles of the feet, are legal parts of the body for weapon attacks.

Some attacks such as Slays are only effective on a specific part of the body. These locations are given in the description of the skill.

## Death and Dying

### Types of Injury

There are different levels of injury that your character can sustain. The simplest injury, Body Point damage, can be directly cured with skills and spells that restore Body Points such as: *Heal Person*, *Battle Surgery*, *Healing Potion*, *Paladin Healing*, *Soothe Your Wounds*, *Heal* spell song, etc. Whenever you lose Body Points for any reason, you tear off a Body Point tag for each Body Point your character has lost. When your character is healed, the player must give you the Power Point tags, skill tags, or item tags to substitute for Body Point tags.

A character can be injured in other ways than Body Point damage. For example, a limb can be incapacitated by a *Stunning Blow*, and only a *Heal Limb* will restore it. Special injuries are described under the skill and spell rules that can cause or cure that type of injury.

### Death and Recovery

When your character has lost all their Body Points, you should fall to the ground, lie still, and start your Death Count. If the ground is wet, muddy, or rocky, you can kneel or crouch; just make sure it is clear to your fellow players that your character is down.

Do not talk to other players out-of-game unless it is necessary. If someone asks, "I examine you, what do I see?" it is okay to say, "You see me bleeding to death," but you cannot yell, "I need a healing spell" or "I'm going to die in sixty seconds! Someone help me!" If you are counting down the amount of time you have left, do so silently unless someone uses *First Aid* or casts a *Detect Life* or *Assess Your Ailment* spell on your character.

No matter how much damage you take, you will never go below -1 Body Points. If your character is at -1 Body Points and you are hit for 10 points of damage, you are still at -1 Body Points. While a character can remove the extremities from a body, the torso is not destroyed with normal damage. After a character is past their Death Count and the player's spirit has not yet left, then things like acid and fire and other destructive effects can destroy a body.

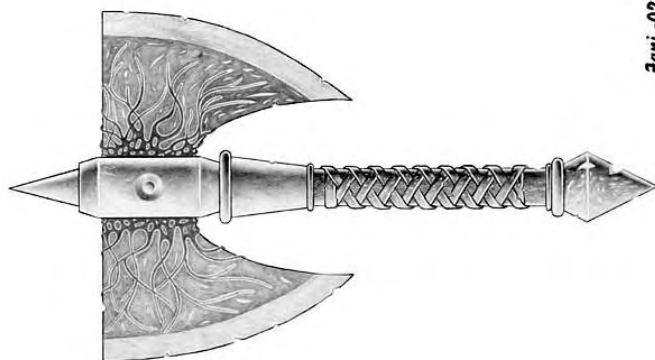

7ani -02

Characters do not die immediately when they go below 0 Body Points. In summary: a character can be Unconscious at 0 Body Points for 5 minutes, then they will wake up; a character can lay dying at -1 Body Point for 1 minute during which they can be healed; a character is at the Brink of Death for 5 minutes and can still be restored by a *Heal Life* spell; after that a character is dead and must be resurrected by a *Return Spirit* or at the Healer's Guild. So, a character that is reduced to -1 Body Points will have a total of 6 minutes to receive healing.

The following chart is a summary of the rules of death and recovery.

Type of Damage	Stage/Status	Time to Heal	How to Heal*
Body Points Reduced to Zero, Waylaid	Unconscious	Will Wake up in 5 minutes and, if originally at 0 Body Points, at 1 Body Points	<i>Heal Person</i>
Body Points Reduced to -1	Bleeding to Death	1 Minute	<i>Heal Person</i> , <i>First Aid</i> , <i>Battle Surgery</i> , <i>Healing Potion</i> , <i>Paladin Healing</i>
Slayed/Assassinated	Mortally Wounded	1 Minute	<i>Heal Mortal Wound</i>
Kill spell, Death Touched, Instant Death poison or Killing Blowed	Brink of Death or Dying	5 Minutes	<i>Life Spell</i> , <i>Paladin Life</i> , <i>Elemental Life</i> , <i>Artifact Life</i> , <i>Draconic Life</i> **

\* This is not an exhaustive list, but a sampling. The skill and spell description will describe how this works.

\*\* Note: Only one type of each of these forms of life can be received per day (7am to 7am). This is not an exhaustive list, but a sampling.

### Unconsciousness

If a character takes enough damage to go to 0 Body Points, that character is Unconscious. If they are undisturbed, they will revive in 5 minutes and be at 1 Body Point.

A character who has been Waylaid is also Unconscious; if left unharmed, they will revive in 5 minutes. If they are healed for at least 1 Body Point or *First Aid* is applied and completed (in other words, the character spends the full, uninterrupted 60 seconds), they will become conscious before the 5 minutes have elapsed.

Skills and spells that restore Body Points will restore an unconscious character, if the character became unconscious due to Body Point damage or a Waylay. If a character is unconscious due to a *Sleep* spell or similar effect, then these healing methods can restore the character's Body Points, but will not wake up the character.

### Bleeding to Death

If a character takes enough damage to go to below 0 Body Points, that character is Bleeding to Death. A dying character is considered to be at -1 Body Points, no matter how much additional damage was taken. If your character has 2 Body Points and is hit for 4 points of damage, your character is at -1 Body Points; if your character is then hit by a 24 point *Inferno* spell the character is still at -1 Body Points. A character goes from Bleeding to Death to Dying if they are not treated within 1 minute of the time they began Bleeding to Death.

### Mortally Wounded

A character is considered Mortally Wounded when they have been affected by a *Slay* or *Assassinate* skill. The character is reduced to -1 Body Points, should lie down, and begin their count. The character has 1 minute to receive a *Heal Mortal Wound* spell or a *Follower of the Light* using their *Healing Pool* to *Heal Mortal Wound*, at which



the Light using their Healing Pool to Heal Mortal Wound, at which time the character is at 1 Body Point. A character goes from being Mortally Wounded to the Brink of Death if they are not treated within that 1 minute.

### **Dying**

A character is at the Brink of Death stage if:

- they were Bleeding to Death and left untreated for more than 1 minute
- they were Mortally Wounded and left untreated for more than 1 minute
- they were given a Killing Blow
- they were hit with a Kill spell or the Death Touch skill
- they were affected by an *Instant Death* poison

A character stays at the Dying stage for 5 minutes. The 5 minutes are counted from the moment the character first went to the Brink of Death stage; for example, if a character is given a Killing Blow while they are Bleeding to Death or Morally Wounded, the 5 minutes is counted from the time when the character received the Killing Blow.

Any life effect is only effective if the character is at the Brink of Death. If a character receives the Life inappropriately, they have not used their chance to receive that type of life later on that day, however, any Power Points are used and any magic item or power is expended. The only exception is the Life skill or Death Touch skill; this is not expended for that Tag Cycle until it is actually used.

When the character is brought back to life, they are restored to 1 Body Point. See the description of Life spell in the Magic chapter for more information.

### **Death**

After the 5 minutes have expired, the character is Dead. Only a *Return Spirit* spell or the Healer's Guild can restore the character to life. In either case, the death is recorded on the character card and the Death System must be used to see if the character has been successfully resurrected. When a character is resurrected in this way, they are restored to their full Body Points. A *Return Spirit* takes a full 10 minutes to cast; if the caster is interrupted during that time, the spell has failed (see the spells description elsewhere in this book).

*Return Spirit* or resurrection in the Healer's Guild will only work if the target character is willing to be resurrected. You cannot force a character to resurrect.

Any spells that the character was under the effects of, including latent spell defenses, are gone should the character resurrect in the Healer's Guild without their body. On the other hand, if the character receives a *Heal Spirit* spell or their body is brought to the Healer's Guild and resurrected, all the character's spells and any other effects will still be present when the character resurrects.

### **Killing Blows**

To force a character to the Brink of Death when they are Unconscious, Bleeding to Death, paralyzed, asleep, or otherwise totally unresisting, a player may deliver a Killing Blow with a weapon, spell or hands. Note that hands can only be used in this one specific case and are not allowed to be used in combat normally.

### **After Your Character is Dead**

If your character is dead, you may remain lying in the spot where your character fell for as long as you wish. Your soul can remain

within your body indefinitely. As long as your character's soul remains with its body, you must continue to lie at the spot where your character fell. You may wish to stay at the spot for several reasons: you hope to receive a *Return Spirit* spell; you want your body to serve as a warning to others; you have decided that you do not want your character to be resurrected and you are hoping for a funeral, and many other possible reasons.

If your character is dead and unresurrectable, then the character's body cannot dissipate. The player may play the body for as long as they wish. If the player does not want to play the body any longer, then a suitable physical representation for the body must be found. Such a representation must be approved by a marshal. The body will still decompose at the discretion of Plot.

When you decide that you have waited long enough, you can become a "spirit". Put on a white headband and go to the Healers' Guild.

When you decide to travel out-of-game to the Healers' Guild to be restored, you become a "spirit" or "wandering soul". The only in-game activity you can perform while a spirit is to go to the Healers Guild to be resurrected. There can be no form of in-game communication between a spirit and any other character. **Spirits may never "phase" or pass through another character and will never produce any in-game effects by their passing. A spirit cannot make others feel anything like cold, or sad or malcontent in any way. A character cannot juxtapose themselves to another character and give them chills or haunting feelings, EVER! A spirit cannot affect the game world in any way, shape or form!**

However, there are several out-of-game activities you may have to perform before you go the Healers Guild. First, you must put on a white headband to indicate that you are out-of-game and your body completely dissipates leaving nothing behind.

Next, leave all your LAIRE items at the spot where your character died, including your money, gems, jewelry, potions, scrolls, and magic items. The only exception is when your character has been killed in an out-of-the-way place and you think it unlikely anyone would ever come to the spot for the rest of the event; in that case, leave all your stuff anyway and tell a Marshal where you died before you resurrect. You may leave your personal weapons and armor where you died or take them to the Armory or the Merchants Guild, but leave the tag at the spot where you died. You are not required to leave your personal costuming and items where you died, however if you wish you may.

If you had any magic items or magic weapons, you should leave the physical representation of the item at the spot where your character fell, but go to the Treasure Manager to give them the magic-item cards. If you are absolutely certain that no one would find the magic item where your body fell, then you can give the item to the Treasure Manager instead of leaving it lost in the woods. But be sure; if the item was important, there may be teams of adventurers scouring the woods looking for it, and they should have their chance to find it.

Once you have disposed of all of your in-game possessions, go to the Healers Guild. When your spirit arrives, lie down or sit and wait for a healer; they will know what to do next. If your spirit arrives at the Healers Guild with any in-game items, your items will be taken and given to the Treasure Manager.

### **In-game vs. Out-of-game**

Here is the formal definition of in-game vs. out-of-game: you are in-game when you are interacting with the game world of LAIRE, you are out-of-game when you are not interacting with the game world,



whether you are attending to some logistical necessity such as tag exchange, a personal errand such as going to the bathroom, or the ultimate disappointment: the game is over until next month.

### ***In-game Behavior***

The game is better if you stay in-game as much as possible. Try to keep out-of-game comments to a minimum; yes, we have seen *Monty Python and the Holy Grail* as many times as you have. Let us look at the Hamlet analogy: it may seem funny to the actor playing Hamlet to stick in a line from *A Streetcar Named Desire*, but chances are it will just make the audience fidget; after all, they came for a good performance of Shakespeare, and the joke just spoils the experience. All of us work together to create the illusion that we are participating in a fantasy world; no one likes it when their work is spoiled.

### ***Out-of-game Behavior***

**If you are out-of-game for some reason – you are tired and taking a break, you are walking to a phone to make a call, you are a spirit and you are going to the Healers Guild to be resurrected – do not interact with the people in-game.** Stay out of areas where there are crowds or combat. If you are out-of-game, stay completely out of the game until you are ready to go fully back into the game; do not hold in-game discussions with other players, or yank off your white headband and go rushing to attack a nearby Orc.

On the other side of the coin, if you see someone wearing a white headband or wearing regular street clothes, ignore them while you are in-game. Obviously there are exceptions to this but try to avoid all out-of-game contact while you are in-game. At best, you would be distracting yourself from your own roleplaying; at worst you could be interfering with other players' enjoyment of the game.

Of course, there are times when you must ask a quick rules question or take a moment for a quick out-of-game activity. Try to keep these actions as brief as possible.

### ***Going In- and Out-of-Game***

**The basic rule is simple, wherever you went out-of-game is where you should come back in-game.** If you put your white head on in your room in the inn and went to your car, you should come back in-

game in your room when you are done. There are some exceptions to this, most notably if a Marshal asks you to put your white headband on for some reason he will generally tell you where and when you can take off your headband and come in-game. The other common circumstance is when you resurrect; when you put your white headband on and become a spirit, wherever you resurrect is where you come back in-game.

The other rule is when going out-of-game or coming back in-game, make sure you are not involved in anything. You should step away from any crowds or if something is going on right in front of where you went out-of-game, wait until it is over before stepping back in-game. For example, if you went out of game by the edge of a field near where your car is parked and when your return there is a large fight, you should wait until it is over before coming back in. Similarly, if you are involved in a fight and have to go out-of-game, make sure you walk out of sight of the combat before you put your white headband on.

### ***Out-of-Game Areas***

Some areas of the camp are always designated out-of-game. The parking lot, the bathrooms, the NPC cabin, out-of-game sleeping areas, and Logistics are all always out-of-game areas. There is no combat or roleplaying allowed in these areas. While you go out-of-game when you enter one of these areas, even without a headband, you cannot run into them from pursuers or other such situations. They are not safe places to hide. The same rules on when and where you can go out-of-game apply to these areas.

There may be other areas of the camp that are off limits and designated out-of-game. Check Logistics for any handouts or attend Opening Ceremonies for any announcements on a month by month, camp by camp basis.

### ***Abuse of the System***

It is poor sportsmanship, not to mention illegal, to go in- and out-of-game whenever it suits your immediate convenience. For example, if you are suddenly surrounded by a group of monsters, you cannot say, "Sorry, I'm out-of-game" unless you were wearing your white headband before they sprang their ambush. Even if you were wearing a white headband, it would be wrong for you to walk over to

your friends, say, "Hey, I know where there are a bunch of monsters waiting in ambush. Let's do a counter-ambush," take off your white headband, and lead an attack on those monsters.

You cannot go out-of-game to perform an in-game action. This includes calling a Hold to collect spell packets or arrows, or putting on a white headband to escape soldiers who are searching for you. For the former, you are responsible for bringing enough props to do what you want to do; it is not fair to make other people stop and wait for you. In the latter case, if you want to hide, then hide; if you know people are searching for your character



but you are tired and you want to go to sleep out-of-game, you must get permission from the Executive Director.

There are times when the game can get difficult to play, and you may be tempted to go out-of-game to avoid trouble. Do not do it. Dealing with difficult situations is part of the challenge of the game, and often brings the greatest rewards.

### ***Sleeping In-Game***

LAIRE runs from Friday night until Sunday afternoon and does not stop in between. Some players are not capable of playing the whole event for medical reasons or otherwise and at every event, special out-of-game sleeping arrangements can be made. You should speak to Logistics when you arrive or specify that you need out-of-game sleeping when you pre-register for the Event.

Sometimes during an Event, a player may really need some sleep, gets injured, or falls ill. In these cases that player must receive permission from the Executive Director to sleep out-of-game. Players that go out-of-game to sleep without permission will be given the appropriate disciplinary action. It is unfair to the other players in the game, everyone would like to sleep safe and sound, but that is part of the thrill of the game and part of the risk and everyone should share in that excitement.



## **Basic Game Play**

This section will introduce you to the basic out-of-game rules that govern the game. Everything from checking in at the beginning of the Event to what are all those small tags everyone has.

Each section is only a brief description of each topic. Later this rulebook goes into more detail and you should look it up.

## **Logistics and Check-in**

When the game of LAIRE is played, your character goes on adventures, lives, dies, is hurt, is healed, uses abilities, and learns new abilities from other characters. The department of LAIRE responsible for keeping track of all these things is called Logistics. The first thing you do each time you attend a LAIRE event is to visit the Logistics area. After you pay to attend the event, you will receive cards and tags which specify everything about your character: how many Body Points they have, what skills they know, the number of times the skill can be used in a day, what spells they can cast, and so forth.

Logistics is open at every event from early Friday night to about 1:00am. In addition, there are Logistics personnel available during the day on Saturday and again after the event is over to collect your cards.

When you arrive at the event you are expected to check in. This entails:

- paying your fees to Finance,
- getting your Character Card,
- getting your tags,
- getting your sleeping assignment, and
- most importantly, getting your NPC work duty.

As was discussed earlier, every player is required to give five hours a weekend to the game in some capacity to help it run. The majority of people NPC, others work logistics, run modules, and other tasks necessary for the game to run. **It is your responsibility to get your work assignment when you check in.**

### ***The Character Card***

The character card is stamped to prove that you paid to attend the event. If you do not have your character card with you, you cannot play. If you lose this card for any reason, put on a white headband immediately and go to Logistics where a temporary replacement will be written out. Avoid the hassle: keep your character card safe and on your person at all times. If you find someone's Character Card, please give it to Logistics immediately.

On your Character Card you will find your name, your character's name, and a list of all the permanent abilities that your character has. Your Character Card represents all the abilities that are inseparable from your character; for example, your character will always be an Elf, always knows Rank 3 Ice Magic, and always knows how to wield a small weapon. If anyone asks out-of-game for proof that you have an ability, you show them your Character Card or show a Marshal. For example, you would show someone your card if your character cast an *Inferno* spell on them and they wanted proof that your character could cast Rank 4+ Ice Magic.

When you receive your card at the Logistics area, check that all the Build Points and abilities that you gained at your previous event are included on the card. The Character Card also lists the number of temporary tags you should receive for each Tag Cycle of the Event.

The back of your Character Card is used to record all the permanent changes made to your character during an event. If your character learns a new skill, the teacher writes the name of the skill and their player number and initials on the back of the card. If you go through a module the Build Points awarded are noted by a Marshal on the back of the card. If your character is killed, the additional death is noted on the back of the card by the person who restores you.

### ***Checking Out***

At the end of an event, you must go to Logistics and check out. Before you get on line, you should make sure you have the following things:

- your Character Card,
- your 1 silver piece upkeep,
- your work assignment duty signed,
- your site (the place you slept) cleanup signed,
- your camp cleanup signed.

Your Character Card is our record of how your character changed during the event; if you do not hand it in, we cannot update your character records with the Build Points you have earned or the new abilities you have gained. If you forget to hand in your Character Card at the end of an Event, your character will not be updated by the next Event, even if you give us your Character Card at a later time.

If your character accumulated a few deaths during an Event, or you received a disciplinary warning, you may be tempted to deliberately "forget" to hand in your Character Card. However, deaths and warnings are recorded separately and *will* be added to your character records even if your Character Card is not handed in. Failure to hand in your Character Card for this reason will result in disciplinary action. So take your lumps and give us your card; at least you will get the Build Points you are entitled to.

If you have to leave before the end of the Event and cannot perform your duty or help clean up, then let someone in-charge know; do not just drop off your card at Logistics. The strict rule is that if you have not done both your work assignment and your clean-up, then you do not earn any Build Points for that Event and any bonus Build Points for going on modules. We are willing to make some exceptions, but you have to ask us first.

### *Up Keep*

The “maintenance fee”, or upkeep, is the amount of game money your character must pay to support themselves between events. You should ask at Logistics what the maintenance fee is for your character; typically it is higher for characters with noble titles or other special positions in society. You pay your maintenance fee when you check out your character from Logistics.

If you do not pay the maintenance fee, your character will be affected in some way. You will find out how your character has been affected at the start of the following event. Effects include, but are not limited to, diseases or loss of Body Points or death.

### **PC'ing**

You are a player, and your character is your representation in the LAIRE game world. You have complete control over your own character, subject to the rules of the game; you control how your character feels, speaks, acts, lives, and dies. In contrast, there are non-player characters (NPC's), whose actions are not fully controlled by their players; these are described in a subsequent section.

Your character could become the greatest hero to ever stride across the world, or the most wicked creature ever to have slinked in the shadows, depending on what you want to do and how well you play the game. We cannot make you a good player you have to do that yourself.

### **NPC'ing**

Of all the volunteer work you can do for LAIRE, by far the most important is... to be a non-player character. The NPC's play all the roles that the players do not: the monsters, the townsfolk, the princes and princesses in distress, the imprisoned dragon that must be rescued from the evil clutches of a dastardly knight. Someone has to play these parts so the other players can have fun.

The most important part of NPC'ing to remember is: **do as you are asked and instructed to do and play the role you are given correctly.** When you are given a role to play at an event you are also given instructions by a Plot, Monster or Module Marshal on what to do and how to play the role. It is important to the storyline and smooth running of the game that you follow these instructions. For example, if you are given the role of a beneficent healer who is sent into town to heal whom ever they can, you should not take it upon yourself to kill as many people as you are able and steal them blind. Neither should you decide to charge people for your healing for any reason.

You should play the role correctly. If you are given a zombie to play you should not charge the line, deftly and acrobatically thrust, parry and break through the line to reach the healers in the back because you think it would be a good tactic. Zombies are slow, mindless creatures that are unable to perform those actions. Additionally, if you meet a lone traveler on the road and cut them down, you should not pick up the body and hide it in the woods – zombies are far too stupid to do this.

Finally, be considerate of your fellow player's feelings. If you do manage to kill a PC or rob them, do not gloat about it to them or return to an out-of-game area and have a laugh at their expense. No one likes to fail and people certainly do not like to be made fun of because of it. Remember, one day that person may be the NPC you are facing as your PC and you would not like them to do such to you.

This is a game and the goal is to have fun, not see how many people you can kill in a single NPC shift.

**Any player that travels more than 350 miles to attend an Event is not required to NPC or perform any other type of 5 hour duty shift.**

### **Brownie and Play Credits**

LAIRE is a cooperative effort. The organization only works when everyone participates to make it work. We are a not-for-profit organization, and we cannot pay you for your efforts on our behalf. Instead, we award Brownie Points (BRP) when you work for us. The basic rate is one BRP for each hour of labor; sometimes the rate is higher for arduous work such as helping to run Logistics.

#### *How to Spend Brownie Points*

Brownie Points may *not* be traded between players. There is one

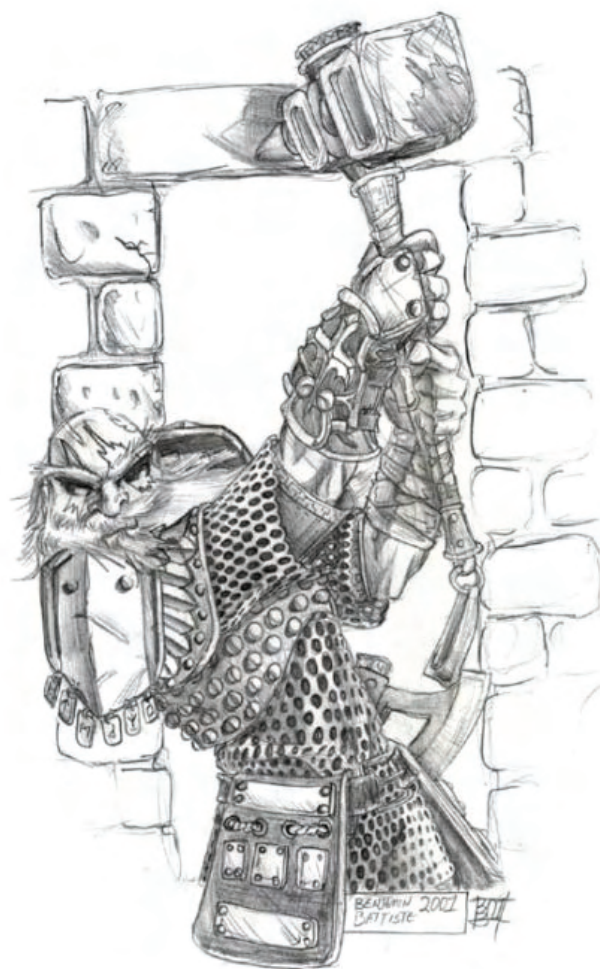



exception: you can give BRP to another player for the sole purpose of helping them buy a new life if they pull a black marble.

Category	Brownie Point Cost
Build for a Character	1 Brownie Point per 0.1 Build Point up to a maximum of half the Awarded Build Points
In-Game Money	Brownie Point to copper pieces ratio will be posted at Events and on Laire.com
Resurrecting from a Black Marble	5 Brownie Points per Black Marble
Spell Defenses	1 Brownie Point per Power Point (3 Brownie Points per Power Point if lost magic) for each non 5 <sup>th</sup> Rank, non warlock enhanced Latent spell

You spend BRP at the end of an event, by telling the Logistics staff person you desire to “brownie your character”. The staff person will note it on your Character Card. If you are using BRP to buy copper pieces, you give your Character Card to the Treasure Manager who will note it on your card. If you are buying a new life, you turn in your BRP at the Healers Guild.

### Earning Brownie Points

On page 275 there is a table outlining the Brownie Points, Build or Play Credits awarded for the various jobs in LAIRE. Not all the jobs listed are described in this rule book. You will learn what each of these jobs are as you play the game.

### LAIRECash

LAIRECash can be used only to offset the cost of LAIRE Events, up to half the cost of the Event. One LAIRECash equals one dollar.

### Play Credits

Every time you go to a full event weekend end, you are required to have one Play Credit. The most common way to earn Play Credits is to NPC a full weekend. From time to time, LAIRE will have a special event usually lasting only a single day or night, for example, the Halloween Party. These events do not require a Play Credit to participate. **Any player that travels more than 200 miles to attend an Event does not require a Play Credit to participate.**

## The Tag System

LAIRE uses tags, 4 inches by 1/2 inch colored, stiff pieces of paper with information that relates to objects and game concepts with a corresponding in-game description written on them. For example, a Slay skill tag denotes that the character can use their Slay skill once in a Tag Cycle, or an alchemical item tag will describe what kind of alchemical substance is in the vial or physical representation.

It is important that you carry your tags with you while you are in-game. If you do not have the appropriate card or tag, then you cannot use the corresponding ability. If your item does not have the appropriate tags, you cannot use your item.

Remember, all skill tags and cards are out-of-game and cannot be stolen by anyone in-game. If you have robbed someone’s pouch and you discover that you stole their tags by mistake, return them immediately.

## Character Tags

These are the tags every character receives with their Character Card. Some tags every character will receive, like Body Point tags. Others represent how many times a Tag Cycle you can use a skill or ability. Lastly, there are pool point tags that represent how much power a character has to use abilities or cast spells.

### Body Points

These tags keep track of how many Body Points a character currently has. When your character takes damage, you should hand over your used Body Point tags to the player that did the damage during a Tag Exchange. When you are healed, you should take the pool points associated with the type of healing you have received and have the caster note how much was healed on the back. These now represent your new Body Points. Since Body Points are not Tag Cycle specific, they are always red in color.

### Skill Tags

Some skills in our game can only be used a limited number of times in a Tag Cycle. When you check in at Logistics, along with your Character Card, you will receive one skill tag for each purchase of a tagged skill for each Tag Cycle. You can only use the tags for the current Tag Cycle. Some examples of tagged skills are: Disarm, Critical Attack, Slay, Weapon Accuracy, Assassinate, Assassin Strike, Total Power, Recover Power, Shape Change, Turn Lesser Undead, Greater Magic Weapon, and many, many more.

### Pool Points

Power Points, Elemental Pool Points, and Healing Pool Points are all examples of pool points that the character may have. Pool points do not do much on their own; they are primarily used to power spells or other effects. For example, Power Points are used to power low magic spells. All pool point tags are color coded for a specific Tag Cycle, and only tags from that cycle can be used.

## Tag Exchanges

As you play the game, you will give players your tags to represent the use of your abilities. For example, if you repair someone’s armor, you will give them the used armor repair tags to use as replacement Armor Points; if you cast a *Heal Person* spell, you will give that person the Power Point tags to use as replacement Body Points; if your character is damaged, you will give your attacker the Armor Point and Body Point tags for the amount of damage you took; if you Slay someone, you will give them the Slay skill tag. The specific use of each type of tag is described under the associated skill in Chapter 5.

Used tags must always be disposed of in some way; they are never recycled back into the game. You may be required to write on the tags to indicate their new use; for example, when Armor Repair tags become Armor Point tags. In this case keep the newly created Armor Point tags with the rest of your armor tags and use them whenever you would normally give away Armor Points. A tag that indicates a one use skill or spell should be torn in half by the target to indicate it has been used. Since we must clean the camp before leaving, please do not throw the tags on the ground; rip them up and put them in your pocket until you can throw them in the trash.

Never hesitate to ask a player for a tag or some other proof that they have a given ability. Likewise, do not take offense because someone asks you for a tag; it is a necessary part of the game. The exchange



of tags helps Marshals to verify that no rules have been broken, and helps players keep track of what their character's current pool of abilities are. There are times when tag exchanges are momentarily inconvenient, obviously do not stop a combat just to exchange tags, but be sure to adjust your tags before the NPCs, or your healers, wander off.

Do not be tempted to short cut the tag exchange procedure. Here is an example of why. You are attacked and damaged by a monster, and then the monster runs off. A spellcaster casts a healing spell on you, saying "Do not bother tearing off your Body Points. I'll just tear up the power points I'm using." The spellcaster walks away. Then the NPC playing the monster comes back out-of-game, and asks you for the tags for the damage that the monster did. Now you are stuck, because you cannot show any proof to the NPC player that you received a healing spell.

All skill and pool tags are color coded. You will receive all the tags for an Event at the beginning of an Event, but you may not use a tag if it does not have the appropriate color for the time of day in which it is designated. For example, if you are told that blue tags are to be used from dawn to dusk on Saturday, you may not use your blue tags on Friday or Sunday. This rule only refers to unused tags; if a latent spell was cast on you on Saturday, the blue tags representing that spell are still good on Sunday of the same Event.

**If you do not play in a Tag Cycle you cannot use tags from that Tag Cycle.** This rule applies to a PC as well as to an NPC.

### *Tag Cycles*

All skill and Power Point tags are color-coded to be used during certain specified intervals during an Event. The following table indicates when to use what tag.

Time	Color
Friday Lay-on – 7am	Pink
Saturday 7am- 7pm	Blue
Saturday 7pm – 7am	White
Sunday 7am - Closing	Green

A simple acronym for remembering the color scheme is: "Pretty Boys Wear Green". You will receive all the tags for an Event at the beginning, but you may not use a tag if it does not have the appropriate color for the time of day.

All latent spells are lost at the end of the Event. Therefore, you are unable to start the event with spell defenses from the previous Event.





## Chapter 2: Creating a Character...

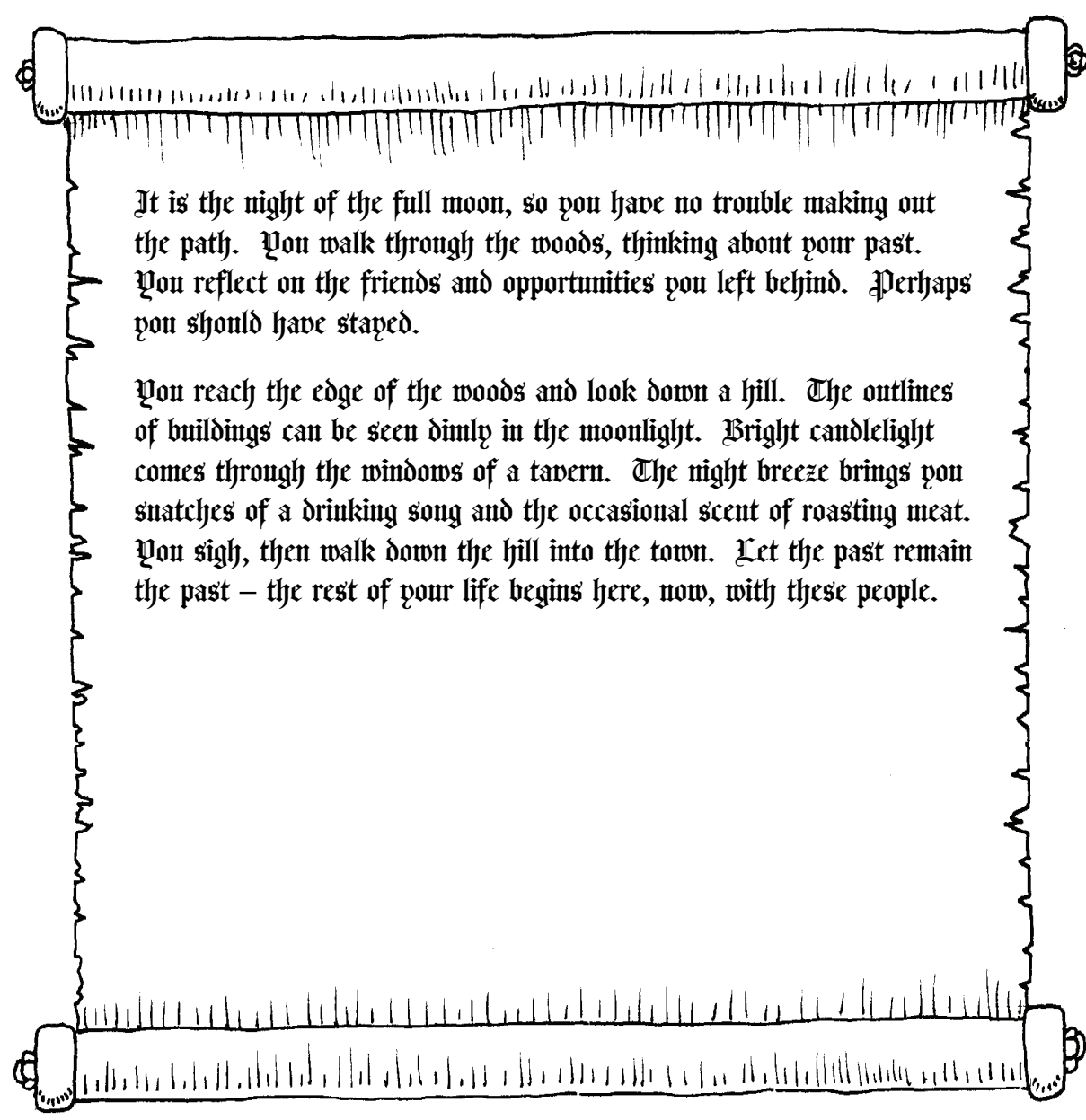

It is the night of the full moon, so you have no trouble making out the path. You walk through the woods, thinking about your past. You reflect on the friends and opportunities you left behind. Perhaps you should have stayed.

You reach the edge of the woods and look down a hill. The outlines of buildings can be seen dimly in the moonlight. Bright candlelight comes through the windows of a tavern. The night breeze brings you snatches of a drinking song and the occasional scent of roasting meat. You sigh, then walk down the hill into the town. Let the past remain the past – the rest of your life begins here, now, with these people.

LAIRE is a fantasy roleplaying game. The better the role you have created for yourself, the more fun you will have. The purpose of this chapter is to help you create an interesting character for both you and the other members of LAIRE.

## Character Background

### The Basic Questions

Here are some questions you can ask yourself when you are creating your character.

#### *What Can Your Character Do?*

Look over the Skill Lists and see what you would like your character to be able to do. You receive 25 Build Points with which to start your character. Using your 25 Build Points, you can purchase those skills that best fit your character.

#### *What Does Your Character Want to Become?*

Look over the description of the Basic and Advanced Career Skill Lists in Chapter 4 and see if any of them matches your character's goals. If your character is going to specialize in one type of Basic Career, it might be worthwhile to purchase a Skill List so that all skills purchased from that list will cost less.

You may want to think about what type of niche you might carve for yourself within the game. For example, you may decide that you want to be Lord High Inquisitor. Is there someone else who already has that role in the game? Who would be the one to appoint you to the job? What can you do to make yourself the obvious candidate for the title?

#### *What Does Your Character Look Like?*

Your costume is an integral part of your character. It is much easier to play the part if you look it. Many players take considerable time and expense with their costumes, and it shows. Better costumes get a player noticed by both other players and the staff alike. In general, avoid devices that were invented in modern times; for example, zippers, blue jeans, t-shirts. Medieval-looking footwear can be expensive, so feel free to wear black or brown work boots.

However, an expensive costume is not necessary to have fun. Even a pair of sweat pants, old boots, and a loose belted shirt can make a good costume; there is always room for another warrior in a simple tunic or tabard. A good way to develop an impressive costume is to start with a few key items and add more as your character advances and your monetary situation allows.

People should be able to look at you and tell something about your character. Your character's race and profession should be apparent from your appearance and roleplaying. You do not have to maintain the classic fantasy stereotypes if you do not want to; not all Dwarves wear heavy armor, carry a battleaxe in one hand and a tankard of Dwarven spirits in the other. However, everyone should be able to identify you from a distance as a Dwarf. Strive to develop a costume, the mannerisms, and the colloquialisms common to the race and profession you portray.

## The Character Description

The next step in developing your character is to write a description of your character's background and submit it to the Plot Committee. The purpose of this description is to give Plot enough detail so they can arrange interesting events that could involve your character. For example, if you write that you have a long lost Uncle Cedric, you may meet that uncle someday; of course, he may have changed since you last met him.

The character description should be as long as you want it to be. If your character can be described in a paragraph, then that is enough. You should keep your history under five pages, and try not to overwhelm the Plot Committee with a lot of detail. The purpose of the character description is to enhance your enjoyment of the game; it is not meant to be a classroom writing assignment.

If you need help or have questions about what you are allowed to put into a character description, you can contact the Plot Committee.

Here are some things to consider when you write your character description.

#### *What is the Story Behind Your Character?*

Many new characters in LAIRE are young and have not had much experience yet: an adventurer fresh from the farm with nothing more than a sword and a will to fight; a spellcaster who has just graduated from magician's school and is ready to put their talents to the test; a ragamuffin who grew up in the forest who is looking for their destiny in a town full of people. Your character does not have to be a youngster; you could be an old retired veteran or mercenary, who took up adventuring to alleviate boredom. Do not let these ideas limit you.

Give your character a past that describes how your character got to be the way they are now. Past events that you include in your character description may come back to affect your character – old enemies, family debts, etc.).

#### *What Obstacles Must Your Character Overcome?*

Do not make life too easy for your character. Some of the most interesting characters in the game are those who have been handicapped by their players in some way. Perhaps your character is cursed and is looking for a cure. Maybe your character has some strange beliefs. Does your character dislike Elves? Hate Dwarves? Believe everything a Gypsy tells them?

#### *What Are Your Character's Goals?*

You should feel free to include a wish list of events or goals that you would like for your character. Is your character looking for a long lost relative? The sword that was stolen from your character's mother in battle? Proof that they are innocent of the murder of a noble in a neighboring kingdom? A long forgotten tome of ancient lore? A chance to meet the Queen of the Elves? A magic gate to the stars?

Do not expect everything you wish for, but expect your wishes to come true when you least expect it.



### Questions to ask When Developing a Character

- Where and when were you born?
- Into what social class were you born?
- Who are your parents?
- Do you have any siblings?
- What was your childhood like?
- Do you have any close friends or enemies?
- What specific goals does your character have?
- How did you come to learn your trade?
- Did you learn or attempt to learn any other trades?
- Are you an adventurer? If so, why?
- Do you currently belong to an adventuring group?
- If so, what is your relationship with these individuals?
- What do you want most in life?
- How do you feel about fame, power, and wealth?
- What tempts your character?
- What would you change about yourself, if you could?
- Do you have any fears or superstitions?
- What is your attitude toward friends, enemies, and strangers?
- What is your attitude toward other races?
- Do you have any prejudices?
- What are your feelings about magic?
- What are your feelings about thieves?
- What are your feelings about nobility?
- Does your character have a set of ethics?

Your relatives:

- Are they still alive?
- What are their professions?
- What are they like?
- Where are their former and current homes?
- What is the nature of your past and current relationship?

### Common Problems

These are the common problems that occur in character descriptions:

- Please do not waste the Plot Committee's time with a wish list that is too extravagant. For example, do not bother to write that your character wants a +3 magic sword; players must earn such treasures on their own.
- Backgrounds that give characters unfair advantages are a dime a dozen. This usually takes the form of a player giving their character a noble title or giving themselves great wealth. If you want a noble title or lots of money, you will have to earn them in-game. This is not a hard and fast rule: if you combine the advantages you give your character with corresponding disadvantages, the Plot Committee may allow it. You once had a noble title but lost it in disgrace; you once had great wealth but squandered it.
- Try to avoid the stereotypes of third rate fantasy novels. For example, you would be amazed how many bastard sons of nobility there are in the game. Create a role that will give you enjoyment, but an original characterization will get you more attention than the usual story of "I'm an Elf and the Dwarves killed my parents and now I seek revenge". However, any goal is better than no goal at all; if you really want to be a character from your favorite fantasy story, go ahead.

After you submit your history, you must get approval from the Plot Committee before your history can be brought in-game and is truth. You can play your character before you get approval, but your history technically does not exist until it is approved.

### Creating a Character

Every player when creating a character needs to decide what race they would like to play and what type of character they are interested in playing. The races are described in the next section and the Basic Careers in the following.

**Every character receives 25 Build Points at the time of character creation.** These Build Points can be spent on any skill on the Basic Career Skill Lists and Miscellaneous Skill List, so long as the prerequisite to purchase the skill are met. This may exclude some skills from starting characters because they only have so many Build Points to spend at the start. These Build Points do not go towards determining a character's level.

Every character gets to pick one Professional skill they want their character to start with for 0 Build Points, if they wish. This is not mandatory; a player may not wish to have their character know a profession. Players who pick Common Man for their race may start with two Professional skills for 0 Build Points.

Some players may have earned Build Points towards their character before they even created one, for example, a player that NPC's an entire Event will earn Build Points for their character. **These extra Build Points earned by doing service for the organization can be used to build a character.** These Build Points are used to determine a character's level, so it is possible to start playing a character that is more than first level. Other sources of Build Points – from Brownie Points or purchased Build Points – cannot be spent on a starting character.

Sometimes a player may not like the character they created and may wish to start over. A player may scrap a character and will receive up to a maximum of 22 Awarded Build Points towards their next character. Only Build Points actually Awarded can be transferred.

Every new character gets the following starting items: any normal armor, one normal shield, two normal weapons, and 15 copper pieces. The player must have a physical representation for each item, except the copper pieces, they bring in and they cannot bring in an item later.

### Character Races and Tribes

There are twenty different races, and several tribes of humans to choose from when making a character in addition to the standard human race. This could be the most important initial choice a player can make. Some races come with large advantages, but they are accompanied with equally large detriments. Some detriments are obvious like restrictions on skills or increased costs of some skills. Others are not so obvious. For example, should a player choose to play a Dark Elf they should consider the in-game dislike many other characters have for Dark Elves and the out-of-game difficulty with applying all the required make-up. Choose carefully what race you would like to play.

Some of the racial advantages and disadvantages gained by playing a race are biological and others are cultural. The game makes no distinction in the racial descriptions below. **However, a player cannot write away their character's racial disadvantages in their character's history.** For example, you cannot choose to play a Northern Barbarian and say you grew up in the Duke of Avalon's

court and therefore have learned to read and cast magic beyond what your racial limitations say. If you do, you are no longer considered a part of that race and have normal human characteristics. Finally, in order to gain the racial benefits of a race, you are assumed to have spent enough time, usually until the age of maturity, with other people of that race.

While choosing a race and during game play, players should put aside standard fantasy stereotypes about fantasy races when dealing with size. All races come in all shapes and sizes. Halflings can be as short as 5 feet or as tall as 7 feet.

### **Costuming Do's and Don'ts**

**No character can wear the costume, in part or in whole, of another race if this leads to any confusion of the character's race.**

The following is a list of examples that are proscribed. It is not a complete list.

- You may not have pointy ears
- You may not wear Tartan or talk in a brogue
- You may not wear black face paint
- You may not wear gaudy clothes and lots of bad jewelry or talk with a Romanian accent
- You may not wear blue, brown, green, or red makeup around your eyes
- You may not wear furs covering more than 25% of your body
- You may not wear braided hair AND furs
- You may not wear earthen colored clothing AND earthen colored beads
- You may not wear a fake beard
- You may not wear two fake, long braids
- You may not wear fake fur on your feet
- You may not wear fake muttonchops
- You may not wear fur/fur like makeup or have a feline/canine tail, feline/canine nose and whiskers, and feline/canine ears
- You may not wear a full green body costume covering the head, body, hands and feet
- You may not wear green, yellow, or brown makeup on your face and exposed skin

Some combinations are okay since they do not lead to confusions. For example, a Half Troll that wears brown leathers with beads and feathers can not reasonably be confused with a Southern Barbarian.

**The final determination on acceptability of a character's costume is made by Plot and Eboard.**

Below is a list of the different races available to play at LAIRE.

## **Humans**

Humans are by far the most prolific race found across Midlantia. Yet even humans come with different abilities gained from the regions and cultures where they live. There are six human cultures or tribes that a player can choose from. There may be other human cultures encountered during game play but only these are available to the player.

### **Common Man**

The stock of all humans, the common man lacks any great strength, toughness, magical aptitude or exceptional dexterity. Indeed they are in a word, average, but they also do not suffer from any of the limitations the other races do. They can be anything, learn anything, and strive for any level of greatness they wish unhindered by racial prejudices, weaknesses or limitations. They do not live especially long compared to Elves, but this only drives them to do more in the time they have and to find a level of immortality in their children. The Common Man is able to live anywhere and make do with what ever they have at hand to forge a life for themselves. Indeed it is in their tenacity to grow, learn and adapt that they are able to take and hold so much of Midlantia.



When dealing with the other denizens of the world, they are able to adapt and use their foes weaknesses against them. The Ogre may be stronger, but the Common Man has magic. Trolls may be tougher but the common man has fire and the knowledge and cunning to use it. Elves may be more magical and have great power at their call, but the Common Man has their martial strength and numbers.

The native literacy for the common man is Common.

### **Barbarians**

Barbarian is the name given to any of the less "civilized" humans that live in the remote or hostile regions of the world. Around Avalon there are barbarian tribes from the frozen north past the Nymidian Empire, to the south in the northern parts of the Plains of Gehenna, and west across the Wolfskael Mountains on the plains and steppes.

#### **Northern Barbarians**



These people live in the harsh, cold climate of the Frozen North where food is scarce and the neighbors hostile. Each clan is composed of large extended families lead by a patriarch. Every clan has its demesne that it frequently roams through heading north in the short summer and back south for the fall through spring. They hunt when game is available and forage if the opportunity presents itself, but their chief means of survival is raiding. Typically, in the fall through spring the tribe survives by raiding their Ice Elf and Nymidian neighbors, and when times are hard, each other. This has made them marked and all

the people in the area seek their eradication making them very xenophobic, even to other Northern Barbarian people outside their tribe. Northern Barbarians do not take slaves or captives, they have nothing to use them for and only cause a drain on their already limited resources.

Both men and women share the responsibilities for tending the tribe's needs and welfare. Both are found equally in the raiding parties and with the tribe caring for the young and wounded, animals and food stocks. There are very few elderly people in the tribe as most do not live long enough to grow old or if they do, are eventually unable to keep up and are left behind.

Northern Barbarians have very little free time to spend pursuing things that do not directly aid the survival of the tribe. There is little or no art work, jewelry or other such frivolous things. Most Northern Barbarians do not take coins, gems or anything they cannot wear, wield or eat as much of their economy – such as it is – is based on trade and their xenophobic nature prevents them from trading with the outside world. They have very little, if any, knowledge of arcane skills or low magic. However, some tribes have managed to hold on to the rudiments of the magical arts. Highly superstitious, they shun magic generally and are very careful on choosing what magics to learn. Their hard, stressful lives leave little room for religion and most do not follow any of the gods. The very few that do, follow the three in equal numbers.

Advantages
<ul style="list-style-type: none"> <li>+1 Damage Bonus with all weapons</li> <li>+5 Body Points at first level</li> </ul>
Disadvantages
<ul style="list-style-type: none"> <li>Cannot learn Sorcery, Warlock, Spell Singing, or Alchemy skills until Level 20</li> <li>Cannot learn any Literacy skill until Level 5</li> <li>Cannot learn Rank 2 low magic until Level 5, Rank 3 until level 10, Rank 4 until Level 15</li> <li>Cannot start game with non-elemental schools of magic</li> </ul>
Costume and Roleplaying Requirements
<ul style="list-style-type: none"> <li>Must wear fur –real or imitation – visibly as part of their costume covering 25% of body and some of their hair visibly in braids.</li> </ul>
Native Literacy
<ul style="list-style-type: none"> <li>None</li> </ul>

### Plains Barbarian

The vast open prairies and plains west of the Wolfskael Mountains are home to the Plains Barbarian tribes. Ranging over almost the entire length of the mountains and many days travel west, the area they cover is vast and most of the time covered in lush vegetation. The plainsmen are expert horsemen and spend most of their time in the saddle riding from hunting ground to hunting ground. There is a harsh divide between the men and women of the tribe. The men hunt and make war; the women tend the young and produce the crafts and items needed by the tribe.

These people are mostly nomadic, but from time to time they venture into the mountains and settle down for a short time, long enough to gather the wood and metals they need to support them over the coming months.

Plainsmen have no fixed territories and frequently different tribes come in contact with each other and war ensues. These people are highly aggressive almost always choosing to fight rather than talk, and to the victor goes the spoils; which not only includes the defeated's goods but their people as well. The plainsmen practice slavery and whole tribes have vanished into slavery in the past. There is no end to the servitude the defeated must pay for defeat, and it is only very seldom that they are freed. However, slavery is not passed onto the children and when a child born to slave parents comes of age; they are freed and welcomed into the tribe.



Though the land is very bountiful, eventually the tribe grows too large to be supported and it breaks up often violently. These new tribes are almost immediately hostile towards each other and sometimes brother is pitted against brother.

The plainsmen are xenophobic but much less so than the Northern Barbarian. They know the value of gold, silver, copper and jewels and when they are found in the mountains, they seek out people to trade with. They have the time to put value on knowledge and have a good oral tradition; some members have even learned to read and write. They know and understand magic and while they do not have the resources or temperament to learn any high level arcane art, they have practiced and keep up with their knowledge of low magic.

The more cerebral pursuits of faith and questions of the origins of the universe have little use to the steppe barbarian. However, some do feel the draw of the powerful skills the Dark Lord has to offer and there are those who seek out his blessings. Few follow the other gods, but there are always some.

Advantages
<ul style="list-style-type: none"> <li>+3 Body Points at first level</li> <li>Free Weapon Skill of Choice</li> </ul>
Disadvantages
<ul style="list-style-type: none"> <li>Cannot learn Sorcery, Warlock, Spell Singing, or Alchemy skills until Level 15</li> <li>Cannot learn Rank 3 low magic until Level 7, Rank 4 until Level 10</li> <li>Cannot start game with non-elemental schools of magic</li> </ul>
Costume and Roleplaying Requirements
<ul style="list-style-type: none"> <li>Must paint eyes black and have black tattoos on face covering 25% of face.</li> </ul>
Native Literacy
<ul style="list-style-type: none"> <li>Common</li> </ul>



### Southern Barbarian

The more peaceful Southern Barbarians that make their home in the wilderness south of Avalon and north of the Plains of Gehenna form more stable tribes than the other barbarians of Midlantia. Exposure to non-violent external influences has taught these people the benefits of semi-permanent living. It is believed that these people originally migrated from the steppes and prairies of the western Wolfskael Mountains and settled in this region either because of some war or natural hardship a long time ago. Their lifestyle has changed and only rarely does the more warlike and aggressive nature of their heritage come through.



They have begun to learn how to farm and have begun to domesticate the flora of the region and cultivate crops in growing quantities, but still rely on gathering for much of their needs. They have begun to learn animal husbandry, but still mostly rely on hunting. They have learned how to craft what they find into more complicated and useful items.

The area they live in supports many rivers and streams and has much arable land for which to lay down a settlement. This semi-stagnant living and surplus of food in good years has given them the time to explore more complex social and political structures. They have the time to explore the mysteries of the universe and have started to come to an understanding of the world around them. Unlike their cousins, they are more mystical in belief and have found a harmony with nature that makes most of them follow the Mother's teachings. Most follow that faith and there are a good number of them that are Druids and Protectors. However, as with any free willed people, there are those who seek out other paths and as their exposure to the outside world grows, so do the number of followers of the High Lord and Dark Lord. They are still superstitious of magic and things they have not learned to understand and, in that, they are much like the other barbarians.

They have shed their xenophobic roots and put down their weapons for other pursuits, which has allowed them to trade with each other and outsiders, and with trade comes new ways of thinking. While they are the most "civilized" of the barbarians, they are still barbarians. Their ways are simple, their society primitive, but they are learning.

They are not, however, free from the rigors of the dangerous world they live in. Frequently the Outlanders from their south raid or come in conflict with the Southern Barbarians over territory and wars erupt. These people have learned to work together more than the other barbarians and this gives them the safety of numbers and strength of unity; but this is not always the case. A strong leader is needed to bring the people together, and if one does not emerge, the whole suffers.

The world can be harsh and in hard times, in order to survive, they turn to their roots and raid others first then eventually each other.

#### Advantages

- Free Weapon Skill of choice  
~ or ~  
On-list cost rebate for two Rank 1 elemental low magic schools
- +2 Body Points at First Level

#### Disadvantages

- Cannot learn Sorcery, Warlock, Spell Singing, or Alchemy skills until Level 10
- Cannot start game with non-elemental schools of magic
- Cannot learn Rank 3 non-elemental low magic until level 7, Rank 4 until level 10

#### Costume and Roleplaying Requirements

- Must wear earthen colored clothing and earthen colored beads and feathers.

#### Native Literacy

- Common

### Outlanders

The Plains of Gehenna are home to a race of barbaric people called Outlanders. Some historians say they are descendants of the Plains Barbarians, similar to the Southern Barbarian, but who settled much farther to the south. Others claim they are human descendants of the once powerful Carthidian Empire. The Plains of Gehenna are dry most of the year, nearly infertile savannas dotted with deserts. The weather is not the only hazard in this harsh land. Anti-magic storms rage across the land destroying all magical items and draining magical energies from anyone who has them. It is these storms that have shaped this race of people the most, changing even their biology. Outlanders are known most for their ability to resist magic and for their intense hatred of mages and magic in almost all its forms.

These people live a nomadic lifestyle, forming two or three extended family sized clans. Some clans are much larger using their strength to influence the other clans. Men and women share the jobs equally except child rearing which is solely the province of women, such tasks being shunned by the men of the tribe so much that even touching a child before the age of maturity is tantamount to a capitul offense. Similarly, women do not fight or take up arms. However, this social mores is not as strictly followed and women, in times of great need, take up weapons to defend the clan and the young. Indeed, these female Outlanders are known for their tenacity and skill in combat which must come from the training all young Outlanders receive.

Outlanders hunt and gather as their primary sources of food. Occasionally the clan will set down temporary roots long enough to grow grains during the wet season in late winter. The hearty, fast growing grains – which only grow on the plains – are highly nutritious and are made into flat breads that keep for a long time and supplement the Outlanders diet throughout the year.

Their other source of food and goods comes from the nearly constant raiding of the Southern Barbarians to their north and people to the west.

The clan is ruled by the strongest and a "might-makes-right" code is pervasive throughout their society. However, Outlanders are not a stupid people and they quickly learn when to and when not to apply their philosophy and with whom. Though in times past women have been heads of clans, it is a rare sight and few people have witnessed this to record the fact.





Outlanders are very xenophobic, and do not tolerate outsiders in their territories. While their might-make-right philosophy often pits clan against clan, Outlanders from different clans do come together for the rare social event.

Outlanders generally do not take slaves when they raid. When it is done, the slave is usually taken as a form of extended punishment and the individual rarely lives longer than a few months under the harsh treatment received.

Outlanders are not superstitious people. They do not bother nor care about such things. The supernatural world around them has all but been destroyed by the anti-magic storms that ravage their countryside. Magical creatures almost all people everywhere take for granted are not seen in these lands. The three powers – the Mother, the High Lord and the Dark Lord – are worshiped equally among the people and this makes up the bulk of their philosophical and supernatural dealings.

Advantages
<ul style="list-style-type: none"> <li>+1 Damage Bonus with all weapons</li> <li>+3 Body Points at Level 1</li> <li>Can purchase the Resist Spell skill and starts the game with two purchases of this skill for 0 Build Points</li> </ul>
Disadvantages
<ul style="list-style-type: none"> <li>Cannot learn the Mage Basic Career Skill List</li> <li>Cannot learn any Arcane skills except Alchemy skills</li> <li>Cannot learn any Literacy skills until Level 15</li> <li>Cannot use latent spells. If cast upon them, they will invoke them to get rid of them.</li> <li>Cannot use magic items until Level 15, but can use faith items at any appropriate time</li> </ul>
Costume and Roleplaying Requirements
<ul style="list-style-type: none"> <li>The player must wear fur visibly as part of their costume covering 25% of their body.</li> <li>Distrustful of magic and strong dislike of mages. They do not have to attack on sight.</li> </ul>
Native Literacy
<ul style="list-style-type: none"> <li>None. Outlanders do not have a written language, preferring to pass down their history orally.</li> </ul>

## Gypsies

Gypsies are wholly nomadic people; traveling around the civilized world in wagon caravans laden with trade goods, trading with everyone they meet. They form very close extended families which are lead by a single member. Gypsies are easily recognized by their flashy dress and excessive, and in most peoples eyes, gaudy jewelry.

Gypsies are not xenophobic but have little respect for anyone not in their family, extending to even other Gypsies. Non-Gypsies are referred to as *Gaja*, and the word carries a negative connotation bordering on a direct insult to anyone labeled as such. Gypsies survive economically solely by trade; satisfying all their needs through trade.

The arrival of these vagabonds is always met with mixed feelings. Some are glad for the goods and coin that Gypsies bring with them. Others lock up their valuables and close their doors in fear of them disappearing mysteriously when Gypsies are in town – whether founded in truth or not. Still others, who have made friends with members of the family, are excited to hear what stories of the outside world the Gypsy caravan brings this time.

Not all Gypsy families are so dismissive of outsiders and have made themselves welcome in various lands and towns. However, all Gypsies share the not unfounded derogatory stereotype of thieves, criminals and miscreants. Whether due to a worn out welcome or to general wanderlust, Gypsies do not stay in one place for too long.

Nobles and indeed the whole feudal political structure is an anathema to Gypsies who refuse to pay nobles of any land any heed or respect. This has made Gypsies unwelcome in many places, but few nobles bring the issue to violence fearing the renowned Gypsy curse. It is not known precisely where this ability to lay a curse on anyone who kills a Gypsy, but it is accepted that this ability is a powerful innate ability in all who are Gypsies, and none are immune from its effects. This has made Gypsies feared by many, and affords the caravan another layer of protection from greedy eyes who covet their goods.

Advantages
<ul style="list-style-type: none"> <li>Half cost for the Rogue Basic Career Skill List (5 Build Points)</li> <li>Can learn Divination and Medium skills for 0 Build Points, may start game with these skills</li> <li>Can purchase the Gypsy Curse skill, and must start the game with this skill</li> </ul>
Disadvantages
<ul style="list-style-type: none"> <li>When speaking in Romany, may only speak the truth. If the character is charmed, they can be compelled to lie.</li> <li>The character must miss four regular, non-special LAIRE Events per year.</li> </ul>
Costume and Roleplaying Requirements
<ul style="list-style-type: none"> <li>Must speak in a Romanian accent at all times.</li> <li>Player must wear brightly colored clothing and gaudy jewelry, which does not have to have an in-game value.</li> <li>Gypsies are very clannish by nature and tend to stay with their clan, doing what they can to support the clan and obey the clan leader.</li> <li>Gypsies tend to be mistrustful of non-clan members.</li> </ul>
Native Literacy
<ul style="list-style-type: none"> <li>Common</li> </ul>

**Highlanders and Celts**

Highlanders and Celts live in the upland regions of mountain ranges north of Avalon. These people live simple lives which some call primitive or even barbaric, but they are neither. If you ask a Celt or a Highlander if they are related, they will tell you yes. These tribes of humans were separated a long time ago and have once more been reunited in recent days..

**Highlanders**

The lower Wolfskael Mountains are the home of the upland peoples known as Highlanders, a people steeped in their own history passed down orally by their Spell Singers – known as Shanahee - and lead by their Druids. They were driven from their homes in the highlands of the mountains by the Bainites, creatures created by the Hierarch Bain and fled to Avalon. Indeed, if it was not for this war a generation ago, Avalon may never have learned of these peoples existence.

Their society is broken down in to large clans – hold outs from generations ago. However, many different clans can be found in one town and as these town relationships grow stronger, the clan loyalties break down. Do not be misguided, the old clan loyalties are very strong still and cause a great amount of friction within the various Highlander settlements.

A clan chief leads a clan, but so does the local leader of a town. How either is chosen is a mystery to any outsider, and maybe even Highlanders themselves. The Shanahee are keepers of history and laws. They are respected and revered within the Highlander society and enjoy a protected and honored status. They are keepers of history and pass this knowledge down orally and through song and prose. Highlanders do not learn to read and write due to the guidance from the Shanahee who teach that writing such things taints and devalues the story.

The other highly influential, and with nearly noble authority, are the Druids. These people are revered and honored and most importantly, obeyed by all Highlanders from any social level. They appear on the surface to maintain a distance from politics but it is obvious to any how strong their influence is over the leaders of the society. Highlanders have Followers of the Light amongst their numbers, and Servants of Darkness as well. Indeed whole clans of Dark Paladins have been rumored to exist.

**Celts**

Found in the upland regions of the Wolfskael Mountains and living throughout the Duchy of Avalon, the Celts now have a nation of their own living along side their Highlander brothers. Arriving late in the last decade from across the ocean as shipwrecked refugees these people have found a home in Avalon. Their old home of Erin was recently destroyed. The survivors, who were saved with the aid of the Heroes of Avalon, have returned to their ancient home in the Highlands.

Many of their old traditions are taking a back seat to the local laws and customs of their new home. However, the old ways die hard



and they still cling to their old traditions whenever possible. Chief amongst them is their reverence, respect and obedience to their Druids.

However set in the old ways they are, the Celts have adapted themselves to Avalonian society and ways and have made many friends and allies.

Recently, the Celts have been taken in by their Highlander cousins and have found a national identity.

**The Geasa**

Every Highlander and Celt character must start the game with a Geasa, which is a superstitious code the character has developed during their lives. Some examples of Geasas are given below:

- Must not walk alone at night.
- Never except a drink for free.
- Only accept spells from other Highlanders.
- Do not start conversations with strangers.

Should a character willingly break their Geasa, they will suffer the following effects:

- Their Body Point total is reduced to half until the character atones.
- The character may only use passive or defensive skills.
- The character can only swing their weapon’s Base Damage, regardless of any Strength Bonus or Damage Bonus they may have.

If a character is compelled by a mind controlling effect, they have not broken their Geasa. The Plot Committee or the Racial Contact will give the player a way to atone for their transgression. This usually takes the character about an hour of in-game roleplaying, but it depends on why the character broke their Geasa and what their Geasa is.

<b>Advantages</b>
<ul style="list-style-type: none"> <li>• Can purchase the Rage skill</li> </ul>
<b>Disadvantages</b>
<ul style="list-style-type: none"> <li>• Has a personal Geasa which must be chosen at character creation.</li> <li>• Cannot learn any Literacy skills until Level 5</li> </ul>
<b>Costume and Roleplaying Requirements</b>
<ul style="list-style-type: none"> <li>• The player must speak in a Scottish Brogue for Highlanders and a Celtic Accent for Celt characters..</li> <li>• The player must wear any color of Scottish Tartan as either a kilt, skirt, dress or trows</li> </ul>
<b>Native Literacy</b>
<ul style="list-style-type: none"> <li>• None. Highlanders and Celts do not have a written language, preferring to pass down their history orally.</li> </ul>

## Elves

Many long eons ago the first elves appeared on the world. They went by many names and were called many things, the most common of which was the Anteanum. These Ancient Elves enjoyed dominance over the world and their domain stretched over the known world. Over the centuries and after the appearance of other races, the Anteanum's numbers dwindled until they faded into obscurity. Their descendants still exist however changed by time.

Rumors persist of sightings of these Ancient Elves whom to this day still live; their immortal lives lived out in a world that has forgotten them.

All elven races share a disdain for all kinds of charms. Along with their dislike for charms they are able to learn a mystical ability to resist the affects of many types of charms. All Elves live for thousands of years, some reaching 4,000 years old. Elves age as humans do until about the age of eighteen, then physically age one year for every fifty years they live.

There are three types of elves a player may choose to play, though there are others that may be encountered during game play, they are not open to players as races they can choose.

Any union between any Elves always results in one of the parent's racial characteristics being dominant. The player therefore has to choose one of the two races to be their character's racial characteristics. For example, if a Gray Elf and a Dark Elf have a child, that child will either look like and have the racial advantages and disadvantages for either a Dark Elf or a Gray Elf, **not** some mix of the two.

### Dark Elves

The exact origins of the Dark Elves are not known to most people. What is known for sure is that their society reveres one of the Hierarchs, Arachnia. These descendants of the Ancient Elves at one time lived above ground with the other Elves until something drove them underground and there they dwelt for millennia until this day, adapting to their new environment.

Dark Elven society is lead by matriarchs and men are second class citizens. It is the women in their society that are the rulers and administrators. The men are soldiers at best and in some cases slaves to the whims of the females.

The Underdark where they dwell is said to be vast and covering below ground what above ground is most of the eastern known world. The Underdark is a dangerous place and few who venture there return. What information is available about the Dark Elven world is learned mostly through turncoats and renegades from their society.

The Dark Elven political structure is as complicated as any other, more so perhaps due to the constant political maneuvering and backstabbing that pervades not only the nobles but down to the lowliest commoner. There is one queen who shares her power with

no one, even though she may have many consorts. There are many noble houses, some great some small, some powerful some weak and all Dark Elves belong to one of these houses. The leaders of these houses have, depending on the influence of the house, great power and the greatest of these collectively have enough influence to influence the decisions of the queen. Life in the Underdark is a constant struggle for position and survival.

The Underdark is not a lifeless wasteland as some may imagine and natural resources abound, enough to make these people self sufficient. When the need for goods that are found in short supply arises, they quickly turn to stealing from the surface races. They take what they need, including slaves, and disappear under ground where they believe themselves safe from reprisals. Dark Elves live long lives but generally do not have the luxury of time to pursue the finer arts. However, some do and their artwork would rival their Gray Elf cousins' beauty and skill, if their works were not tainted by their dark hearts and thoughts. Few find their works pleasing to the eye and there is little market for their goods.

Given all this, Dark Elves still have free will and some do not abide by their societies' moral choices and find themselves hiding their true nature from their own family, friends and people. This makes life particularly hard on Dark Elves who chose not to follow along with the dark wishes of their leaders. Many choose the surface world as a means of escape where they are only marginally more accepted by the people on the surface. Lands such as Avalon, with its laws that protect rather than punish the populace give these outcasts a place to try and live in peace. Even though the overwhelming number of Dark Elves are evil and to some extent follow the Dark Lord, free will has allowed some to be Followers of the Light and others Druids.



Advantages
<ul style="list-style-type: none"> <li>• Half cost for the Rogue Basic Career Skill List (5 Build Points)</li> </ul>
<ul style="list-style-type: none"> <li>• +1 Damage Bonus for all weapons during the night (7pm to 7am) or while completely underground</li> </ul>
<ul style="list-style-type: none"> <li>• Can purchase the Elven Resist skill</li> </ul>
<ul style="list-style-type: none"> <li>• Can purchase Poison Immunity: Sleep Poison as a racial ability for 3 Build Points. May start the game with this skill.</li> </ul>
<ul style="list-style-type: none"> <li>• Can purchase the Blind Fighting skill as a racial ability for 3 Build Points. May start the game with this skill.</li> </ul>
Disadvantages
<ul style="list-style-type: none"> <li>• -2 Body Points at first Level</li> </ul>
<ul style="list-style-type: none"> <li>• Double cost for the Stamina skill (8 Build Points)</li> </ul>
<ul style="list-style-type: none"> <li>• -1 Damage Bonus during the day (7am to 7pm)</li> </ul>
<ul style="list-style-type: none"> <li>• Cannot learn the Charm School</li> </ul>
Costume and Roleplaying Requirements
<ul style="list-style-type: none"> <li>• The player must wear black pointed ears and black makeup on their face and exposed skin. Most Dark Elves have white hair, but this is not required.</li> </ul>
Native Literacy
<ul style="list-style-type: none"> <li>• Dark Elven</li> </ul>



### Gray Elves

The Gray Elven nation on Midlantia is in the heart of the Mistwood. Ruled by the Elven Queen, their cities which blend into the forest are the heart of these people's lives. They are great mages having a natural affinity for magic, but can also be warriors and rogues.

These people are aloof and proud, claiming a more direct decent from the Anteanum. They look down on all other races – even other elves – as inferior and either treat them with disdain or patronizing simplicity. Their attitude towards the other races has earned them few true allies. All Gray Elves are not so insufferable, however, and indeed their society is as good as the Dark Elf society is evil. Their benevolence, even tainted as some may say by their arrogance, is the reason they do have friends, namely the Duchy of Avalon which for almost its entire existence has had an alliance with the Elves of Mistwood.

Gray Elves are isolationists, preferring to close the outside world from their lives. Some Gray Elves, however, have ventured forth from their cities and the Mistwood and sought out the outside world, some simply find life in the Mistwood boring and seek adventure. Many find their way to Avalon where their magical aptitude allows them easily to find a place in Avalonian society.

The Elven Queen rules her people with the aid of the Elven high nobles, each representing a noble house. In this way too, Gray Elves are similar to Dark Elves, but their laws rather than promoting strife, conflict and turmoil in the pursuit of power, protect the people they are placed upon.

Gray Elves are long lived and their long lives, powerful ancient magic, and graceful skill allows them to be great creators of all forms of art and music. Not all Gray Elves are artisans, but with hundreds of years of practice there is little a skilled Gray Elf craftsman cannot do. Gray Elves trade with the outside world and their crafts are highly sought after and this trade has made the Gray Elf nation very wealthy, even perhaps beyond what outsiders could imagine.

Most Gray Elves tend to be good, though being free willed creatures some have sought out means of power to satiate their darker desires. Few chose to follow the Mother, preferring their cities to the wild and they often leave the pursuit of such things to the Wood Elves, but they still hold the Mother in high regard.



#### Advantages

- +2 Power Points for the first 3 levels (+6 Power Points Total)
- Half cost for the Mage Basic Career Skill List (5 Build Points)
- Can purchase the Elven Resist skill

#### Disadvantages

- -2 Body Points at Level 1
- Double cost for the Stamina skill (8 Build Points)
- Increased cost for Rogue Basic Career Skill List (15 Build Points)
- Cannot learn the Charm School

#### Costume and Roleplaying Requirements

- The player must wear pointed ears and blue makeup around the eyes.

#### Native Literacy

- Elven, Common

### Wood Elves

These descendants of the Anteanum have taken to living in the lush and beautiful forests and glades of the Mistwood, preferring to sleep as close to nature as they can. Wood Elves form small agrarian communities, living in blissful harmony with the land. Wood Elves practice little politics and while they have a king, their ultimate allegiance is to the Elven Queen who graciously takes care of the politics and administration of the Mistwood. While some may speculate that this would cause reason for dissention, nothing could be farther from the truth. Truly most Wood Elves just do not care or bother with such matters.



Wood Elves do not act nearly as haughty and arrogant as Gray Elves, in fact compared to Gray Elves they are positively humble. If not for their solitary nature with other Wood Elves, these Elves would find it much easier to work with other races. This is not to say they are not prideful, in fact they may be even more proud than Gray Elves, believing they have found the one true path all Elves should follow. However they do not foster their ideals on others and therefore do not seem as aloof.

Wood Elves have little to no economy within their society, preferring to share or at most trade for the things they need. What they do produce in surplus is sent to the cities of the Gray Elves to be traded with the outside world. When not tending to their environs, Wood Elves rival the Gray Elf skill at craftsmanship, again due to their long lives and great amount of skill as opposed to any biological disposition. Wood Elves have a natural affinity with the use of bows and indeed many can use one better than most.

Wood Elves hold the Mother in highest regard, which should come as no surprise given their preferred lifestyle. There are, to be sure, Wood Elves that have found this way of life unsatisfying and have found fulfillment following other paths including worship of the



other Powers. Indeed, many who come to Avalon are in search of another way of life from being warriors to powerful mages.

Advantages
<ul style="list-style-type: none"> <li>+1 Damage Bonus with all bows</li> </ul>
<ul style="list-style-type: none"> <li>Weapon Skill: Bow skill for 0 Build Points</li> </ul>
<ul style="list-style-type: none"> <li>Can purchase the Elven Resist skill</li> </ul>
<ul style="list-style-type: none"> <li>Can purchase the Tracking skill as a racial ability for 3 Build Points. May start the game with this skill.</li> </ul>
Disadvantages
<ul style="list-style-type: none"> <li>-2 Body Points at Level 1</li> </ul>
<ul style="list-style-type: none"> <li>Double cost for the Stamina skill (8 Build Points)</li> </ul>
<ul style="list-style-type: none"> <li>Cannot learn the Charm School</li> </ul>
Costume and Roleplaying Requirements
<ul style="list-style-type: none"> <li>The player must wear pointed ears and brown makeup around the eyes</li> </ul>
Native Literacy
<ul style="list-style-type: none"> <li>Elven</li> </ul>

## Dwarves

The Dwarven nation appeared in the mountains of this part of the world well before the founding of any human settlements. Said to be old enough as a race to have known the Ancient Elves, the Dwarves have changed little over the long years since their appearance. Dwarves as a people suffer from a magical deficiency that makes it difficult for them to become mages of any kind.

Though they consider themselves one people, most non-dwarves recognize two races of Dwarves; the Hill Dwarves who live in the lower hills near the mountains and the Mountain Dwarves who live deep inside the mountains. The closest Dwarven kingdom to Avalon is found in the Black Hills, the mountain range north and west of Avalon.

There is one king of the Dwarves who rules over all Dwarven people. There are Dwarven knights and lords, but no known high nobles. Their society has its share of farmers, herders, and craftsmen, mostly among the Hill Dwarves. The underground lands of the Mountain Dwarves provide little of the sustenance for their people, instead Mountain Dwarves mine, and mine with a great tenacity. Stone and ores of all kinds are their chief export.

While life in and on the mountains is not harsh, it is dangerous. Many of the creatures of the Hierarchs – Goblins, Orcs, Trolls and Ogres – have taken refuge and live there. Underground, the Dark Elves of the Underdark war with the Mountain Dwarves nearly constantly, both having a great hatred for the other.

Dwarves worship the three gods at about the same frequency. Many Mountain Dwarves are warriors, though a few overcome their magic weakness and pursue the higher magical arts. Hill Dwarves are craftsman, but also pursue careers as warriors, rogues and a few even as mages. Counter to popular belief, Dwarves live about as long as humans do.

Any union between any Dwarves always results in one of the parent's racial characteristics being dominant. The player therefore has to choose one of the two races to be their character's racial characteristics. For example, if a Mountain Dwarf and a Hill Dwarf have a child, that child will either look like and have the racial advantages and disadvantages for either a Mountain Dwarf or a Hill Dwarf, **not** some mix of the two.



### Hill Dwarves

Advantages
<ul style="list-style-type: none"> <li>Half cost for the Armor Smith skill (1.5 Build Points)</li> </ul>
<ul style="list-style-type: none"> <li>Half cost for the Weapon Smith skill</li> </ul>
<ul style="list-style-type: none"> <li>Can purchase the Dwarven Resist skill</li> </ul>
<ul style="list-style-type: none"> <li>+5% Bonus to Alchemical Success Rolls</li> </ul>
Disadvantages
<ul style="list-style-type: none"> <li>Cannot learn Power Points until Level 5. Can have a maximum of 7 Power Points per Level starting at Level 5 (i.e. 42 PP at Level 10).</li> </ul>
<ul style="list-style-type: none"> <li>Cannot use bows, may use crossbows</li> </ul>
<ul style="list-style-type: none"> <li>Can only learn one Warlock skill every other level starting at Level 15</li> </ul>
<ul style="list-style-type: none"> <li>Cannot learn Sorcery until Level 15 and receives a -15% Ritual Casting Bonus</li> </ul>
<ul style="list-style-type: none"> <li>Cannot learn Spell Singing skills until Level 15 and can only earn a rank of Spell Singing every 5 Levels starting at Level 15. Then can have only a maximum of 6 Spell Singing Points per level starting at Level 15</li> </ul>
Costume and Roleplaying Requirements
<ul style="list-style-type: none"> <li>The player must wear a brown or red beard if they are playing a male character – even if they have a real beard – or two long brown or red braids of hair if they are playing a female character.</li> </ul>
Native Literacy
<ul style="list-style-type: none"> <li>Dwarven</li> </ul>

**Mountain Dwarves**

Advantages
<ul style="list-style-type: none"> <li>+1 Strength Bonus, Non-Combinable</li> </ul>
<ul style="list-style-type: none"> <li>+2 Body Points for the first three Levels (+6 Body Points Total)</li> </ul>
<ul style="list-style-type: none"> <li>Can purchase the Dwarven Resist skill</li> </ul>
Disadvantages
<ul style="list-style-type: none"> <li>Cannot learn Power Points until Level 5. Can have a maximum of 7 Power Points per Level starting at Level 5 (i.e. 36 PP at Level 10).</li> </ul>
<ul style="list-style-type: none"> <li>Cannot use bows, may use crossbows</li> </ul>
<ul style="list-style-type: none"> <li>Can only learn one Warlock skill every other Level starting at Level 15</li> </ul>
<ul style="list-style-type: none"> <li>Cannot learn Sorcery until Level 15 and receives a -15% Ritual Casting Bonus</li> </ul>
<ul style="list-style-type: none"> <li>Cannot learn Spell Singing skills until Level 15 and can only earn a rank of Spell Singing every 5 Levels starting at Level 15. Then can have only a maximum of 6 Spell Singing Points per level starting at Level 15</li> </ul>
Costume and Roleplaying Requirements
<ul style="list-style-type: none"> <li>The player must wear a black beard if they are playing a male character – even if they have a real beard – or two long black braids of hair if they are playing a female character.</li> </ul>
Native Literacy
<ul style="list-style-type: none"> <li>Dwarven</li> </ul>

**Halflings**

Halflings are merry folk who, though frail of stature, are crafty and make skilled artisans. The Halfling's love of good food and drink is renowned and indeed these people are often found in a tavern indulging their desires. Halflings make poor warriors and usually depend on their cleverness and stealth to protect them.

Halflings originally come from Gleneden, a land next to the Wolfskael Mountains in western Nymidia. Recently they have found a new home in the Barony of the Dale and indeed many Halflings hail from there.

Their home in New Gleneden in the Dale mirrors their life style in old Gleneden. That is to say, life is generally good there. Halflings live up to their reputation and spend a great deal of their time eating and drinking ales and wines and singing and dancing. They live a simple life of farming and tending to their small herds of animals.

Halflings produce a vast surplus of food but seldom see it that way and eat most of it. Sometimes however they do sell it for goods and services needed by the community as a whole. There are many, many craftsman among the Halflings and their goods are sought after by many outsiders. While their goods and surplus of food has made them a target in the past for raiders, their new home in Avalon affords

them a level of security they have not been used to in past generations.

Halflings who do not farm or craft can be found adventuring around the world and have a reputation for being exceptional rouges getting into all kinds of places they were not meant to go. Some Halflings take up the Arcane skills but few if any become outright warriors, though there have been some to be sure. Most Halflings are too busy being happy to worry about matters of faith and few pursue such things. However, some have chosen to pick a faith and take up that fight for one of the world's powers.

Advantages
<ul style="list-style-type: none"> <li>Half cost for the Rogue Basic Career Skill List (5 Build Points)</li> </ul>
<ul style="list-style-type: none"> <li>Reduced cost for all Craftsman skills (1 Build Point each)</li> </ul>
<ul style="list-style-type: none"> <li>+1 Damage Bonus with all thrown weapons and Small Weapon skill</li> </ul>
Disadvantages
<ul style="list-style-type: none"> <li>-2 Body Points at Level 1</li> </ul>
<ul style="list-style-type: none"> <li>Double cost for the Stamina skill (8 Build Points)</li> </ul>
<ul style="list-style-type: none"> <li>Double cost for the Warrior Basic Career Skill List (20 Build Points)</li> </ul>
<ul style="list-style-type: none"> <li>Cannot use or learn the following weapons: <ul style="list-style-type: none"> <li>✓ Pole-Arms</li> <li>✓ 2-Handed Weapons</li> <li>✓ Bastard Weapons, including Spears</li> <li>✓ A Shield Larger than Shoulder to Waist.</li> </ul> </li> </ul>
Costume and Roleplaying Requirements
<ul style="list-style-type: none"> <li>The player must wear fur on the tops of their feet and mutton chops for males and curly cues in front of ears for females.</li> </ul>
Native Literacy
<ul style="list-style-type: none"> <li>Common</li> </ul>

**Mystical Races**

These races are strange and varied, indeed, creatures right out of story books. Their histories and societies are varied, but all share a mystical nature that makes them far from human.

**Kaletani**

Kaletani are an intelligent race of feline humanoids that developed through the ages. They are not the product of human coupling in any way as some have suggested. These civilized people are highly adept at magic and most of them are mages of some kind.

Kaletani are mostly encountered living with other races, primarily with humans in their cities and towns. Many of their numbers come from the unpopulated plains and woods around the Duchy of Avalon where they live in small groups much as their animal kin do.



Kaletani meet from time to time during the year to exchange stories, goods and magical knowledge and training. There are no social distinctions between the sexes and all tasks are shared equally. Most Kaletani practice magic though some are accomplished thieves while few train in martial skills.

Kaletani mingle with most races without much conflict save those races who shun magic. It is through this sharing of community that Kaletani gain their knowledge of other races and nations and not through trade as most other cultures do.

Long ago in the early years of this race, Necromancy and those who wield this magic caused great harm to their people, a fact no Kaletani forgets. This deep rooted hatred for this magic has made them staunch opponents to its use and aggressively oppose its spread. This has become such a feature of this race that they no longer possess the ability to use the magic in any form and have found it much easier to learn Healing.

Kaletani are free to follow any of the three paths. Most who do choose to follow a path chose to be a Druid or Follower of the Light. Few choose to become Servants of Darkness and those that do still carry their racial dislike of Necromancy.

Advantages
<ul style="list-style-type: none"> <li>+3 Power Points for the first two Levels (+6 Power Points Total)</li> </ul>
<ul style="list-style-type: none"> <li>Half cost for the Mage Basic Career Skill List (5 Build Points)</li> </ul>
<ul style="list-style-type: none"> <li>The Natural Claws skill</li> </ul>
<ul style="list-style-type: none"> <li>Half cost for each rank of the Healing School</li> </ul>
Disadvantages
<ul style="list-style-type: none"> <li>Double cost for all Master Warrior skills</li> </ul>
<ul style="list-style-type: none"> <li>Cannot learn any necromantic skill or ability including the Necromancy School and necromantic rituals.</li> </ul>
Costume and Roleplaying Requirements
<ul style="list-style-type: none"> <li>The player must wear fur on exposed areas of the body except face and hands which requires fur makeup, a feline tail, feline nose and whiskers, and feline ears</li> <li>Must attack undead whenever possible and prudent</li> <li>Will not wear any wholly metallic armor such as plate mail or chain mail. They can wear studded leather armor.</li> </ul>
Native Literacy
<ul style="list-style-type: none"> <li>Kaletani, Common</li> </ul>

### Saurians

Saurians come from the Great White Swamp in western Avalon. They live in semi-nomadic tribes throughout the swamp; setting down roots when food is plentiful. While both males and females share most responsibilities, it is the females that tend the young and males that hunt. Food is usually abundant in the swamp and food is rarely a concern for the tribe. However, there are many dangers in the Great White Swamp, some stemming from the environmental hazards others from the other denizens of the swamp.

Saurians are considered barbaric by most races, but these people have an appreciation for the finer things in life, they just do not have the free time to pursue them. These people find it difficult to learn magic, but once they grasp the concepts, they can excel at it.

Saurians are able to spit a poison that will paralyze their targets; making it easier to catch their prey. They also have a reputation for their weakness of good music, indeed they will enter an almost helpless state when they sit and listen to it for too long. Aggressive actions taken near or upon them will snap them out of their trance and most get very angry at being disturbed. Saurians are cold blooded and if exposed to cold temperatures; they will slow down and if left alone can fall completely asleep until they warm up. Elves are very wary of Saurians for the former are the favorite food of the latter.



Saurians are not predisposed to follow any of the Powers and indeed, each can claim about the same number of followers.

Advantages
<ul style="list-style-type: none"> <li>+1 Strength Bonus, Non-Combinable</li> </ul>
<ul style="list-style-type: none"> <li>2 Threshold</li> </ul>
<ul style="list-style-type: none"> <li>Can purchase the Poison Spit skill and must start the game with one purchase of this skill</li> </ul>
<ul style="list-style-type: none"> <li>The Natural Claws Skill</li> </ul>
<ul style="list-style-type: none"> <li>Can purchase the Swim Skill for 0 Build Points and must start the game with this skill.</li> </ul>
Disadvantages
<ul style="list-style-type: none"> <li>Color blind</li> </ul>
<ul style="list-style-type: none"> <li>Double effect from ice attacks</li> </ul>
<ul style="list-style-type: none"> <li>Double cost for the Mage Basic Career Skill List (20 Build Points)</li> </ul>
Costume and Roleplaying Requirements
<ul style="list-style-type: none"> <li>Must wear a full body costume covering the head, body, hands and feet and a lizard like tail. Coloring can be any combination of earth tones: brown, reds, yellow, and green. The costuming must have scales.</li> <li>Saurians are cold blooded and if exposed to cold temperatures, they will slow down and if left alone can fall completely asleep until they warm up.</li> <li>Distracted by good music and will enter a dream like state if not disturbed, can react normally if attacked.</li> </ul>
Native Literacy
<ul style="list-style-type: none"> <li>Common</li> </ul>



## Wolfen

Wolfen are intelligent, civilized canine humanoids. They, like the Kaletani, have no ties to humans and are a race unto their own. Wolfen tend to be earthy and gruff, which many claim make them uncivilized, but this is not true. They are loyal to anyone they consider part of their pack. This could be as small as an adventuring party, or as large as the village they live in. They make no distinction in race when it comes to members of the pack. In unpopulated areas, especially wooded areas, Wolfen packs are composed entirely of Wolfen, but when found living along side other races, the Wolfen may be the only one of their race in the pack.



Wolfen have an affinity towards martial skills and lack the magical aptitude needed to make them accomplished wielders of magic. Their sense of loyalty to the pack makes them excellent soldiers and guards and when found living with other races, these are the roles they frequently take. However, some Wolfen take up other pursuits and become craftsman or artisans, but their numbers are few.

Wolfen, like most races, follow the three Powers at about the same ratio and make up a small percent of the population.

Advantages
<ul style="list-style-type: none"> <li>Half cost for the Fighter Basic Career Skill List (5 Build Points)</li> </ul>
<ul style="list-style-type: none"> <li>One purchase of the Critical Attack skill for 0 Build Points</li> </ul>
<ul style="list-style-type: none"> <li>+2 Body Points for the first two Levels (+4 Body Points Total)</li> </ul>
<ul style="list-style-type: none"> <li>The Natural Claws skill</li> </ul>
Disadvantages
<ul style="list-style-type: none"> <li>Can have only a maximum of 6 Power Points or Spell Singing Points per Level.</li> </ul>
<ul style="list-style-type: none"> <li>Double cost any Sorcery skills, -10% Ritual Casting Bonus</li> </ul>
<ul style="list-style-type: none"> <li>Double cost any Warlock skills</li> </ul>
<ul style="list-style-type: none"> <li>Double cost any Spell Singing skills, 1 Spell Singing Point for 1 Build Point</li> </ul>
Costume and Roleplaying Requirements
<ul style="list-style-type: none"> <li>The player must wear canine ears and fur on exposed areas of the body except face.</li> <li>Pack mentality, obeys pack leader and puts members of the pack before self.</li> </ul>
Native Literacy
<ul style="list-style-type: none"> <li>None. Wolfen do not have a written language, preferring to pass down their history orally.</li> </ul>

## Half Breeds

Most races cannot interbreed, they are simply too dissimilar to create offspring. Some, however are similar enough that occasionally a child is born from their union. Humans are the only race that can create half breeds. These children are usually, but not always, sterile and cannot have offspring of their own. If both parents are of the same half breed they will create a half breed child. If one of the parents is of pure blood, they will always create a pure blooded child. Dissimilar half breeds never produce any offspring, so if a Half Orc and a Half Elf mate they will never produce an offspring.

Only humans have the genetic similarity to other races that will produce half breeds. Therefore, there will never, ever be a half Orc, half Elf or a half Elf, half Dwarf or a half Wolfen, half Lesser Saurian.

The offspring of the monstrous races will always have free will even though their parent did not, a gift of their free willed parent. Except for Half Elves, half breeds live as long as humans do. Half Elves live about 1,000 years and age as humans do up to about eighteen years old, then physically age about one year for every ten years of life.

### Half Elves

The result of a human and any elf, all Half Elves look the same. They have the same racial characteristics regardless of what kind of Elf the parent was.

These people are shunned by the elves and often find it hard to fit in with humans. Stuck between two worlds, they tend to be a lonely solitary people.

Advantages
<ul style="list-style-type: none"> <li>Can purchase the Elven Resist skill, purchasable once every other level</li> </ul>
Disadvantages
<ul style="list-style-type: none"> <li>-1 Body Points at Level 1</li> <li>Cannot learn the Charm School</li> </ul>
Costume and Roleplaying Requirements
<ul style="list-style-type: none"> <li>The player must wear pointy ears and no makeup.</li> </ul>
Native Literacy
<ul style="list-style-type: none"> <li>Common, Elven (or Dark Elven if the character is a Half Dark Elf)</li> </ul>

### Half Ogres

Half Ogres have a parent who was an Ogre and a parent who was a human. These half breeds are exceptionally strong, very tough, and very proficient fighters with two handed weapons. They are, however, in a word, dumb and lack the intelligence of their human parentage. They find magic almost impossible to learn. They are somewhat clumsy and they find it difficult to learn Dexterity skills.

Most human societies fear the half breed and shun them, and Ogres find them weak runts and abuse them. Very few Half Ogres find a place to live with people.

Most Half Ogres are an expression of extremes, doing nothing in moderation. Some are exceptionally kind and nonviolent while others are particularly cruel, but all are savage and fierce in combat or when angered.



Advantages
<ul style="list-style-type: none"> <li>+1 Strength Bonus</li> </ul>
<ul style="list-style-type: none"> <li>+1 Damage Bonus with all weapons</li> </ul>
<ul style="list-style-type: none"> <li>+3 Body Points for the first three Levels (+9 Body Points Total)</li> </ul>
Disadvantages
<ul style="list-style-type: none"> <li>Double cost for Mage Basic Career Skill List (20 Build Points)</li> </ul>
<ul style="list-style-type: none"> <li>Double cost for all Arcane skills on the Mage Basic Career Skill List</li> </ul>
<ul style="list-style-type: none"> <li>Double cost for the Rogue Basic Career Skill List (20 Build Points)</li> </ul>
<ul style="list-style-type: none"> <li>Double cost for all Dexterity skills</li> </ul>
<ul style="list-style-type: none"> <li>Double cost for all Literacy skills</li> </ul>
<ul style="list-style-type: none"> <li>Cannot learn any Sorcery skills</li> </ul>
<ul style="list-style-type: none"> <li>Cannot learn any Warlock skills</li> </ul>
<ul style="list-style-type: none"> <li>Cannot learn any Spell Singing skills</li> </ul>
<ul style="list-style-type: none"> <li>Cannot learn any Alchemy skills</li> </ul>
Costume and Roleplaying Requirements
<ul style="list-style-type: none"> <li>The player must wear yellow makeup on their face and all exposed skin.</li> <li>Half Ogres are dim witted and naïve and takes twice the normal time of in-game roleplay to learn skills</li> </ul>
Native Literacy
<ul style="list-style-type: none"> <li>None.</li> </ul>



### Half Orcs

Half Orcs are by far the most intelligent of the monstrous half breeds, and with great determination can learn magic. They might not be as strong as a full Orc, but their intelligence allows them to survive and even thrive in Orc society. They might not be as smart as humans, but their toughness and strength allows them to find their place in human society.



Advantages
<ul style="list-style-type: none"> <li>+1 Strength Bonus, Non-Combinable</li> </ul>
<ul style="list-style-type: none"> <li>+3 Body Points at Level 1</li> </ul>
Disadvantages
<ul style="list-style-type: none"> <li>Double cost for all Spell Singing skills, 1 Spell Singing Point for 1 Build Point</li> </ul>
<ul style="list-style-type: none"> <li>Double cost for all Literacy Skills</li> </ul>
Costume and Roleplaying Requirements
<ul style="list-style-type: none"> <li>The player must wear green makeup on their face and all exposed skin. Cannot wear a pig nose.</li> </ul>
Native Literacy
<ul style="list-style-type: none"> <li>Common</li> </ul>



### ***Half Trolls***

Half Trolls are the toughest of the half breeds and quite strong; making them excellent warriors. Their low dexterity makes them somewhat unsuited to being rogues. They are more intelligent than Half Ogres and can learn some low magic, if not with difficulty, but they lack the intelligence and magical nature needed to wield high magic.

Along with their Troll parent's strength, they share their vulnerability to fire. Like all half breeds, Half Trolls find it difficult to find a place in either Troll or Human societies, and like the Half Ogre, their savage natures tend to come through when their emotions run high.

Advantages
• +1 Strength Bonus
• +4 Body Points for the first four Levels (+16 Body Points total)
• +2 Damage Bonus with claws
• The Natural Claws skill
• Can learn Feat of Strength skill as a racial, starts the game with one purchase for 0 Build Points
Disadvantages
• Double cost for Mage Basic Career Skill List (20 Build Points)
• Double cost for the Rogue Basic Career Skill List (20 Build Points)
• Double cost for all Literacy skills
• Cannot learn any Sorcery skills
• Cannot learn any Warlock skills
• Cannot learn any Spell Singing skills
• Cannot learn any Alchemy skills
• Double effect from fire attacks
Costume and Roleplaying Requirements
• The player must wear brown makeup on their face and all exposed skin.
• Slow to learn higher philosophical concepts.
Native Literacy
• None.

## Introduction to Skills

LAIRE is a live action game, and many of the things a player can do in the game are only limited by what they can physically perform. If a character wants to move silently through the woods, then the player does it; if a character wants to spot a bird two miles away, then the player looks; if a character wants to make a dramatic speech that will make people willing to fight and die for them, then the player says it.

However, LAIRE is also a fantasy game, and it allows characters to perform tasks that people in the real world cannot. A skill is the game mechanic that allows a character to interact with the game world and perform things they would otherwise be unable to do. Players acquire skills for their characters by spending Build Points, and players get Build Points by adventuring. Build Points are sometimes referred to as just Build.

In order for a character to be able to perform any of the skills listed in this rulebook, the player must purchase that skill. Just because a player can do something in “real life” does not mean their character can perform the skill in the game. For example, AJ may already be a locksmith in the real world, but any of his characters must have the Pick Locks skill before he can attempt to pick a lock in-game.

A character gains skills and abilities by earning Build Points. By attending an event, players automatically earn Build Points for their character. In addition, a player may receive Roleplaying Chips (RC's) for conspicuous roleplaying.

### Skill Costs

A player acquires skills for their character by spending Build Points. The cost of some skills depends on whether a character has a corresponding Skill List or not. There are three Basic Career Skill Lists and no Skill Lists for the Advanced Careers. A Skill List is not a skill by itself, but it makes the purchase of skills cost less. The purchase of a Skill List represents a general, overall knowledge of a field; it does not help a character perform any skills better, but it makes it easier to learn skills in that field.

There are three Basic Career Skill Lists that cost Build Points to learn and gives a player's character a cost reduction on those skills. They are: Warrior Basic Career Skill List, Mage Basic Career Skill List, and Rogue Basic Career Skill List. The rest of the lists in our game refer to groupings of skills that share a similar career. For example, the Master Warrior Skill List contains all the skills appropriate to Master Warriors. This does not imply that a Master Warrior would not have access to other skills in the game, just that these are the skills associated with the Master Warrior Advanced Career.

There are two costs for almost every skill listed on the Basic Career Skill Lists. The first is the list price; this is the price a character pays when they have purchased the Skill List. The second higher cost is the non-list cost; this is the Build Point cost to buy the skill if a character has not already purchased the Skill List.

If a character has already purchased skills in a list and then decides to purchase the list itself, the character will get back the extra Build spent on those skills.

*For example, Avirim Darkfire purchases the Polearm skill for 12 Build off list. Later, he learns the Weapons Skill List for 10 Build. He would get back 7 Build, the difference between the off list and on list cost of the Polearm skill.*

Note that this is the *only* way a character can reallocate Build already spent; a character cannot “give back” or unlearn a skill and get a

Build Point refund. Additionally, the character must have the full 10 Build Points on their Character Card to learn the new Skill List.

There is no penalty for knowing multiple Skill Lists, and a character may know as many as they wish and have the Build Points to spend.

## Basic Career Skill Lists

As stated a few times earlier in this chapter, there are three Basic Career Skill Lists which the player can choose for their new character. The player also has the option of just buying the skills off those lists and skills from the Miscellaneous Skill List. A character is not required to purchase one of these Skill Lists, but it is a smart choice. Many of the Advanced Careers require one of these lists as a prerequisite to learning skills from that career and it does save the character some Build Points. Similarly, there is nothing saying a player cannot learn all three lists if they wish, but it is also advantageous to the player's character to focus their character on a specific career track. However the choice is ultimately up to the player.

The three Basic Career Skill Lists each cost 10 Build Points and the Miscellaneous Skill List, like the Advanced Career Skill Lists, has no Build Point cost associated with it and all the skills on the list have only one cost. The three Basic Career Skill Lists are:

- Warrior Basic Career Skill List
- Mage Basic Career Skill List
- Rogue Basic Career Skill List

### Warrior Basic Career

Those players who wish their characters to fight and have the skills and Body Points to make them good at it, should choose this Basic Career and the skills associated with this list. Warriors have a long tradition in fantasy fare to be the ones in the middle of the fighting, going toe to toe with all manner of monsters and villains. It is arguably the most physically demanding – on the player – career in the game.





Many character archetypes fit in this Basic Career, the mercenary, bodyguard, soldier, and adventurer. Indeed, even footpads, highwaymen, and thugs can be made by purchasing this Skill List and later augmenting the character's skills with a few Rogue skills.

Warriors can learn any Weapon Skill, Shield Skill, or fighting style in the game. They can also learn a few basic, yet very effective, martial skills that will help them survive a fight.

The only Advanced Career that is associated with this career is the Master Warrior. There are other Advanced Careers that the character may pursue that do not depend on a Basic Career for its basis, namely the Alchemist, Spell Singer, Druid, Follower of the Light or Servant of Darkness.

### *Mage Basic Career*

What is a fantasy game without the Mage? Most fantasy involves magical elements of some kind and there always seems to be a mage – for good or for ill – involved in the story. Mages in many fantasy stories and games go by various names: wizard, sorcerer, warlock, witch, spell caster, thaumaturge, etc. In our game, any character that casts magic is a Mage. Sorcerers and Warlocks are specialized mages and those names are reserved for those characters that pursue those Advanced Careers.

There are numerous and varied character archetypes that fit in this Basic Career: hedge wizards, students of magic, combat mages, healers, etc. Magic in our game augments well with other careers to help to round out a character but it takes a committed amount of time and Build Points for a character to reach the higher ranks of magic; dabblers abound but masters are few.

Mages can learn any School of Low Magic in our game and purchase their Power Points at a reduced cost. They can also easily learn to read magic but have a limited number of weapons to choose from.

The Warlock and Sorcerer are the Advanced Careers that are associated with this list. The Alchemist and Spell Singer careers do not require the character to start out as this Basic Career. The character may also choose to follow one of the faiths and become a Druid, Follower of the Light or Servant of Darkness.

### *Rogue Basic Career*

Of all the career paths a player can choose for his character, none require the player to have as much out-of-game skill as the Rogue. These players must be able to do almost all the classic feats a fantasy Rogue can do. Even many of the skills a character will learn require the player to perform the task. Rogues in LAIRE are varied in how they apply their skills. They are the burglars, cutpurses, footpads, scouts, spies, sneaks, lookouts, treasure hunters, etc. of the fantasy genre.

Rogues can learn to fight with many more weapon types than the Mage but not as many as the Warrior. All of their fighting styles revolve around stealth, speed and dexterity. Additionally, the player will be able to choose from a few basic but useful skills to round out their character.

When a character is ready to advance their career they will have two choices, the Master Thief and the Assassin. There are other Advanced Careers that the character may pursue that do not depend on a Basic Career for its basis, namely the Alchemist, Spell Singer, Druid, Follower of the Light or Servant of Darkness.

## Sample Characters

Below are some examples of starting characters. They are here to give an idea what a starting character looks like and some suggestions to help a new player make their first character.

### *Sample Starting Fighters*

Sword and Board Fighter 1	
10	Warrior Basic Career Skill List
2	Weapon Skill: One-Handed Edge
5	Shield Skill
5	Critical Attack
2	First Aid
10	<b>Body Points</b>
0	<b>Power Points</b>

Sword and Board Fighter 3	
10	Warrior Basic Career Skill List
2	Weapon Skill: One-Handed Blunt
5	Shield Skill: Large Shield
4	Disarm
4	Stamina
11	<b>Body Points</b>
0	<b>Power Points</b>

Florentine Fighter 1	
10	Warrior Basic Career Skill List
2	Weapon Skill: One-Handed Edge
3	Florentine
10	+1 Weapon Proficiency: One-Handed Edge
10	<b>Body Points</b>
0	<b>Power Points</b>

Florentine Fighter 2	
10	Warrior Basic Career Skill List
2	Weapon Skill: One-Handed Edge
3	Florentine
4	Disarm
2	First Aid
4	Stamina
11	<b>Body Points</b>
0	<b>Power Points</b>

Two-Handed Weapon Fighter 1	
10	Basic Career Skill List
4	Weapon Skill: Bastard Edge
10	+1 Weapon Proficiency: Bastard Edge
9	<b>Body Points</b>
0	<b>Power Points</b>



<b>Two-Handed Weapon Fighter 1</b>	
10	Basic Career Skill List
4	Weapon Skill: Two-Handed Edge
5	Critical Attack
4	Disarm
9	<b>Body Points</b>
0	<b>Power Points</b>

### Sample Starting Mages

<b>Combat Mage 1</b>	
10	Mage Basic Career Skill List
1	Enchantments School
1	Bonds School
2	Pyrotechnics School
2	Weapon Skill: Quarter Staff
9	Power Points
5	<b>Body Points</b>
17	<b>Power Points</b>

<b>Combat Mage 2</b>	
10	Mage Basic Career Skill List
1	Enchantments School
2	Ice School
1	Bonds School
0	Weapon Skill: Small Weapon
10	Power Points
18	<b>Body Points</b>
15	<b>Power Points</b>

<b>Healer</b>	
10	Mage Basic Career Skill List
2	Auras School
2	Healing School
2	First Aid
9	Power Points
5	<b>Body Points</b>
17	<b>Power Points</b>

<b>Scholarly Mage</b>	
10	Mage Basic Career Skill List
2	Ice School
1	Thaumaturgy School
4	Literacy: Common
1	Read Magic
7	Power Points
5	<b>Body Points</b>
14	<b>Power Points</b>

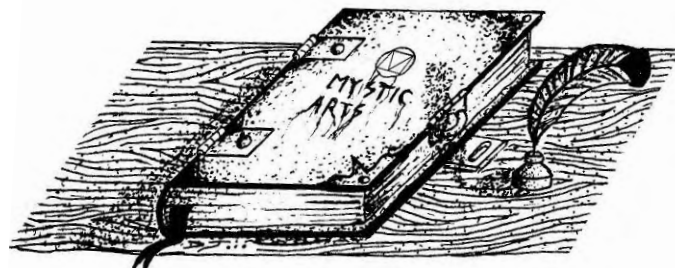

### Sample Starting Rogue

<b>Mugger</b>	
10	Rogue Basic Career Skill List
0	Weapon Skill: Small Weapon
2	Weapon Skill: One-Handed Edge
5	Waylay
6	Backstab
2	First Aid
6	<b>Body Points</b>
0	<b>Power Points</b>

<b>Burglar</b>	
10	Rogue Basic Career Skill List
0	Weapon Skill: Small Weapon
2	Weapon Skill: One-Handed Edge
3	Florentine
2	Pick Locks
2	Disarm Traps
4	Evaluate Item
2	First Aid
6	<b>Body Points</b>
0	<b>Power Points</b>

<b>Assassin in Training</b>	
10	Rogue Basic Career Skill List
0	Weapon Skill: Small Weapon
2	Weapon Skill: One-Handed Edge
5	Waylay
2	Herbal Lore
4	Literacy: Common
2	Poison Lore
6	<b>Body Points</b>
0	<b>Power Points</b>

<b>Scout</b>	
10	Rogue Basic Career Skill List
0	Weapon Skill: Small Weapon
2	Weapon Skill: One-Handed Edge
2	Weapon Skill: Thrown Weapon
3	Florentine
5	Waylay
2	Pick Locks
6	<b>Body Points</b>
0	<b>Power Points</b>

## Warrior Basic Career Skill List

The Warrior Basic Career Skill List costs 10 Build Points to purchase and may only be purchased once. For a full description of the skills, see Chapter 5.

Warrior Basic Career Skill List						
Skill	Cost		Duration	Prerequisite Skill	Purchase	Tagged
	On-List	Off-List				
<b>Weapon Skills:</b>						
Small Weapon	0	0	Constant	None	Once	No
One-Handed Edged	2	6	Constant	None	Once	No
One-Handed Blunt	2	6	Constant	None	Once	No
Bastard Sword	4	12	Constant	None	Once	No
Bastard Blunt	4	12	Constant	None	Once	No
Two-Handed Edged	4	10	Constant	None	Once	No
Two-Handed Blunt	4	10	Constant	None	Once	No
Quarterstaff	2	6	Constant	None	Once	No
Spear	3	8	Constant	None	Once	No
Polearm	5	12	Constant	None	Once	No
Thrown Weapon	2	6	Constant	None	Once	No
Bow	3	9	Constant	None	Once	No
Crossbow	4	12	Constant	None	Once	No
Shield	5	15	Constant	None	Once	No
Florentine	3	9	Constant	Any One-Hand Weapon Skill	Once	No
Weapon Proficiency	10	15	Constant	Any Weapon Skill	Multi	No
Critical Attack	5	10	Instant	Any Weapon Skill	Multi	Yes
Disarm	4	8	Instant	Any Weapon Skill	Multi	Yes
Stunning Blow	6	12	Instant	Weapon Proficiency	Multi	Yes

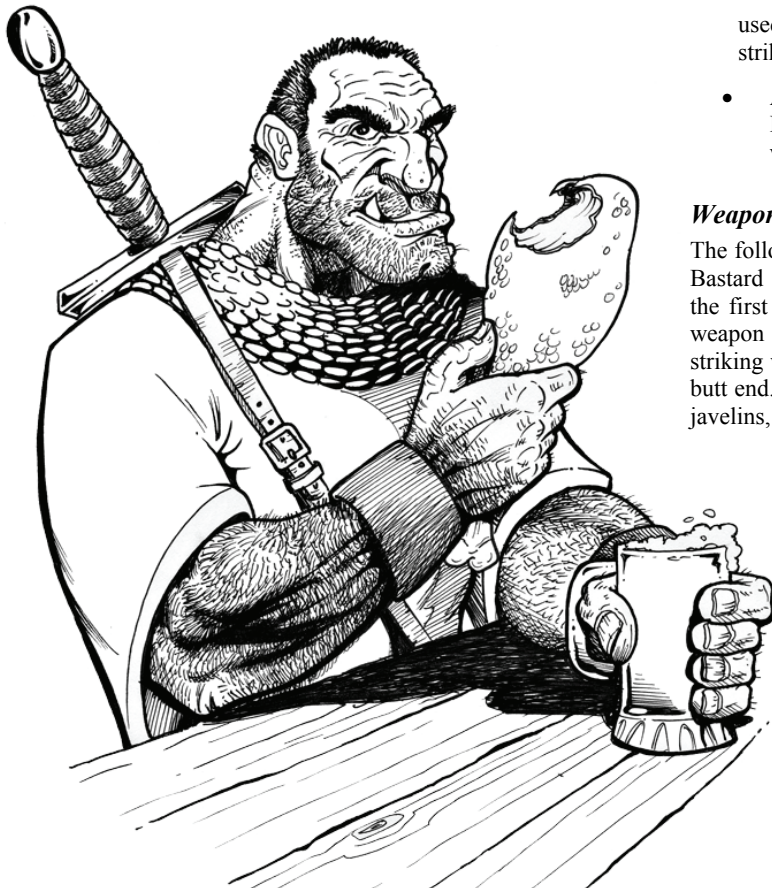

### Special Notes for the Warrior Basic Career Skill List

The following are some special notes and rules for the Warrior Basic Career Skill List. They are as follows:

- If a character purchases a one-handed and two-handed Weapon skill, they are able to use bastard weapons of the appropriate type. For example, if a player purchases One-Handed Edge and Two-Handed Edge they are able to use Bastard Edge Weapons.
- Two-handed weapons – Two-Handed Sword, Two-Handed Blunt, Polearm, Staff, and Bows – must be used with two hands to cause damage. However, the player may use these weapons with one hand to block.
- Bows and Crossbows may not be used to block an attack for they are too delicate. The one exception is Magic or unshatterable Bows, these weapons can be used to block attacks in melee combat but cannot be used to strike with in melee combat.
- All weapons gain the benefit of the character's Strength Bonus except Crossbows. Bows count as two-handed weapons.

### Weapon Damage

The following table outlines how much base damage a weapon does. Bastard Sword, Bastard Blunt, and Spear have two numbers listed, the first is using the weapon with on hand the second is using the weapon with two hands. For Polearms, the first number is for striking with the head, and the second number is for striking with the butt end. Lastly, all thrown weapons deal 1 point of damage, except javelins, which deal 2 points of damage.

Weapon Type	Damage
Small Weapon	1
One-Handed Edged	2
One-Handed Blunt	2
Bastard Sword	3/2
Bastard Blunt	3/2
Two-Handed Edged	3
Two-Handed Blunt	3
Quarterstaff	2
Spear	3/2
Polearm	4/2
Thrown Weapon	1/2
Bow	3
Crossbow	4

## Mage Basic Career Skill List

The Mage Basic Career Skill List costs 10 Build to purchase and may only be purchased once. When you buy this Skill List, you automatically get an award of 3 Power Points. For a full description of the skill, see Chapter 5.

Mage Basic Career Skill List						
Skill	Cost		Duration	Prerequisite Skill	Purchase	Tagged
	On-List	Off-List				
Read Magic	1	6	Constant	Any Literacy	Once	No
Power Points	1.5 PP per 1 Build	1 PP per 1 Build		None	Multi	Yes
Auras School	2/2/2/2/4	5/6	Constant	<i>See Below</i>	Multi	No
Bonds School	1/2/2/2/4	3/6	Constant	<i>See Below</i>	Multi	No
Charms School	1/2/2/2/4	3/6	Constant	<i>See Below</i>	Multi	No
Death School	1/2/2/2/4	3/6	Constant	<i>See Below</i>	Multi	No
Demonology	3/3/4/4/6	7/9	Constant	<i>See Below</i>	Multi	No
Enchantments School	1/2/2/2/4	3/6	Constant	<i>See Below</i>	Multi	No
Healing School	2/2/2/2/4	5/6	Constant	<i>See Below</i>	Multi	No
Ice School	2/2/2/2/4	5/6	Constant	<i>See Below</i>	Multi	No
Necromancy School	2/2/2/2/4	5/6	Constant	<i>See Below</i>	Multi	No
Pyrotechnics School	2/2/2/2/4	5/6	Constant	<i>See Below</i>	Multi	No
Thaumaturgy School	1/2/2/2/4	3/6	Constant	<i>See Below</i>	Multi	No
<b>Weapon Skills:</b>						
Small Weapon	0	0	Constant	None	Once	No
Quarterstaff	2	6	Constant	None	Once	No

### Special Notes for the Mage Basic Career Skill List

The following are some special notes and rules for the Mage Basic Career Skill List. They are as follows:

- The Build costs separated by slashes are the costs for each rank in the school of magic. Those ranks outlined and grayed out are lost and cannot be learned easily in Avalon. For example, the list cost of the Death School is given as 1/2/2/2/4; this means that the 1<sup>st</sup> Rank Death School costs 1 Build, 2<sup>nd</sup> Rank Death School costs 2 Build, 3<sup>rd</sup> Rank costs 2 Build, etc. and 5<sup>th</sup> Rank is lost and cannot be easily learned.
- No rank above two can be purchased off-list. Therefore, there is no off-list cost for 3<sup>rd</sup> Rank or higher Schools on the Table.
- The prerequisites for purchasing the next rank of a school is given in the table below:

Rank	Character Level	Power Points
1	1 <sup>st</sup>	3
2	3 <sup>rd</sup>	25
3	5 <sup>th</sup>	50
4	7 <sup>th</sup>	75
5	9 <sup>th</sup>	100

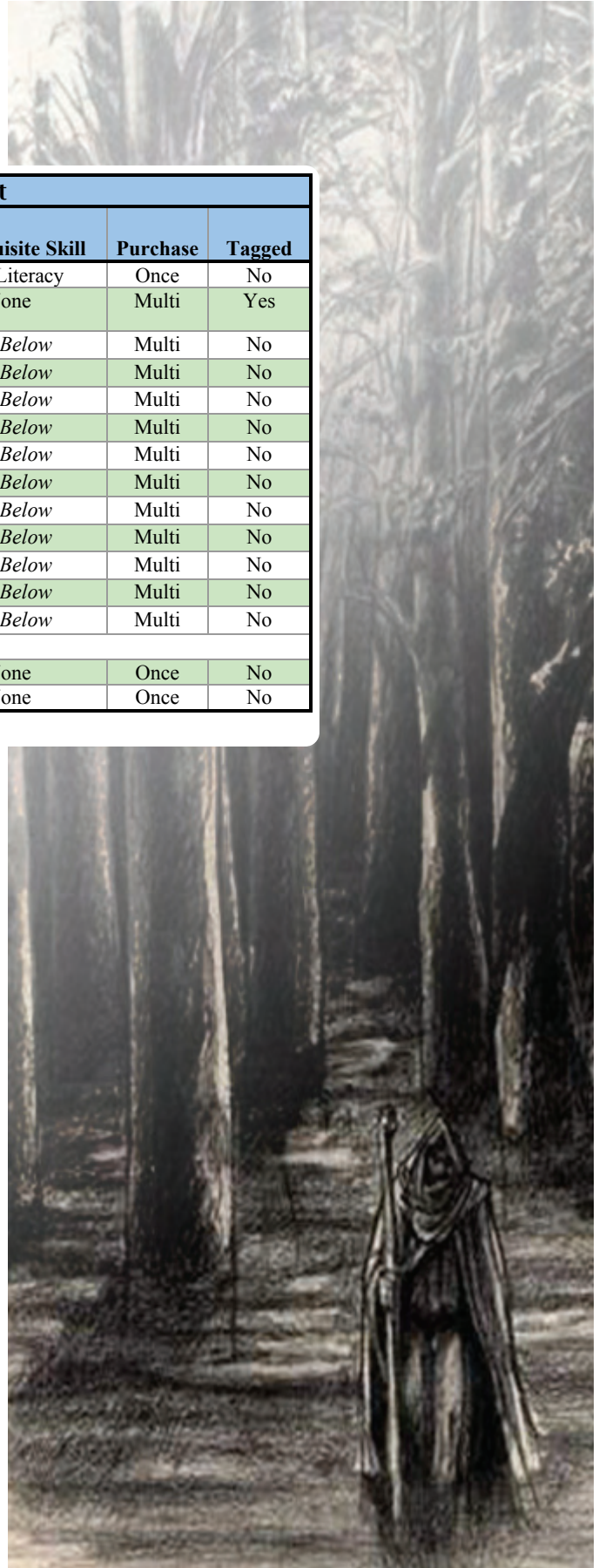



## Rogue Basic Career Skill List

The Rogue Basic Career Skill List costs 10 Build to purchase and may only be purchased once. For a full description of the skill, see Chapter 5.

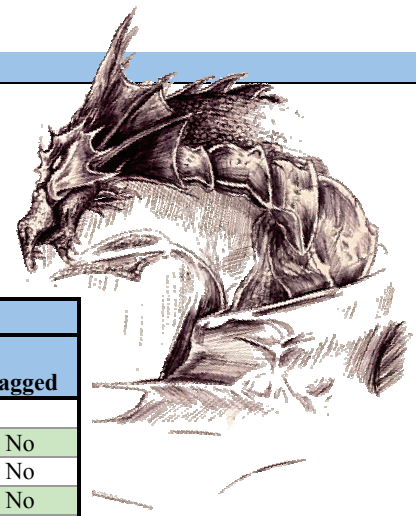

Rogue Basic Career Skill List						
Skill	Cost		Duration	Prerequisite Skill	Purchase	Tagged
	On-List	Off-List				
<b>Weapon Skills:</b>						
Small Weapon	0	0	Constant	None	Once	No
Thrown Weapon	2	6	Constant	None	Once	No
One-Handed Edged	2	6	Constant	None	Once	No
Crossbow	4	12	Constant	None	Once	No
Bow	3	9	Constant	None	Once	No
Florentine	3	9	Constant	None	Once	No
Disarm Trap	2	6	Constant	None	Once	No
Set Trap	1/2/3/4	3/6	Constant	Disarm Trap	4	No
Pick Lock	2	6	Constant	None	Once	No
Waylay	5	15	Constant	Small Weapon	Once	No
Backstab	6	12	Constant	Waylay	Multi	No
Poison Lore	2	6	Constant	Literacy, Herbal Lore	Once	No
Poisons Rank 1	2	6	Constant	Poison Lore	Once	No

### Special Notes for the Rogue Basic Career Skill List

- The Build costs separated by slashes are the costs for each rank of the Set Trap skill. For example, the on-list cost is given as 1/2/3/4; this means that the first purchase of this skill costs 1 Build Point, the second costs 2 Build Points, and so on. A character can only purchase this skill twice off list.

## Miscellaneous Skill List

There is no list cost associated with the Miscellaneous Skill List, therefore, there are no on- or off-list skill costs associated with it. For a full description of the skill, see Chapter 5.

Miscellaneous Skill List					
Skill	Cost	Duration	Prerequisite Skill	Purchase	Tagged
First Aid	2	Constant	None	Once	No
Battle Surgery	4	<i>Special</i>	First Aid	Multi	Yes
Stamina	4	Constant	None	Multi	No
Superior Strength	15	Constant	None	Once	No
Advanced Strength	10	Constant	Superior Strength	Once	No
Herbal Lore	3	Constant	None	Once	No
Evaluate Item	3	Constant	None	Once	No
Literacy	4	Constant	None	Multi	No
Armor Smith	3	<i>Special</i>	None	Multi	No
Weapon Smith	4/6/8/10	Constant	None	Multi	No
Craftsman Skills	3	Constant	None	Multi	No
Professional Skills	1	Constant	None	Multi	No
Divination	3	Constant	None	Once	No
Instructor	3	Constant	None	Once	No
Medium	3	Constant	None	Once	No
Researcher	3	Constant	None	Once	No
Quick Study	3	Constant	None	Once	No
Torture	3	Constant	None	Once	No

### Special Notes for the Miscellaneous Skill List

- The Build Point costs separated by slashes are the costs for each rank of the Weapon Smith skill.

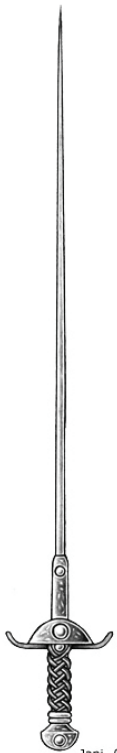

Jani -03



### ***Special Weapon Smith Rules***

The Weapon Smith skill is purchased in ranks. Each rank allows the character to make more complicated weapons. Additionally, the higher ranks of the Weapon Smith skill allow the character to create weapons of quality. All weapons require stock material which is purchasable in-game from the Armory or out-of-game from the Treasure Manager.

A character can create any number of normal weapons they wish in between Events. They need to pay the production cost for the raw materials to the Treasure Manager and receives the appropriate weapon card. If a character wishes to make a weapon during an Event, they must spend the indicated time in-game. All special weapons must be made in-game.

In addition to the stock materials, the character also needs access to a forge. A character can find a forge in the City of Avalon in the Armory. The player needs to find out in-game what their character needs to do to gain access to the forges in the armory.

The production times listed in the following table indicates how much time the character must spend making the listed weapons. All times, after the initial base crafting times, are cumulative. Therefore, if a character wanted to make a permanently silvered, unshatterable long sword with a +1 Damage Bonus, they would need to spend 1 hour and 30 minutes at a forge to complete the work. The time spent must be uninterrupted, but does not require concentration to complete. If the character is forced to stop their work, the task fails and the stock materials lost. The character may talk to other characters or move around the forge performing the forging. They may cast spells, fish an item out of a pouch, or perform other simple tasks, but not engage in combat for more than 30 seconds or move more than 20 feet from the forge.”

The costs of the stock materials must be found out in-game. With the exception of Mithril weapons, any broken weapon can be re-forged if the pieces are present. The base cost needs to be paid again and the time spent forging the weapon. Weapons destroyed with the *Shatter* spell, *Blast* spell and Shatter Weapon skill render the weapon into pieces too small to reasonably find or re-forged. Read the descriptions below for more information on re-forging those types of weapons.

Below is an explanation of the various special weapons and crafting skills listed in the table. All crafting must be done at the time the weapon is made with the exception of Metal Coatings, which is done after the weapon is constructed. Any combination of these crafting skills is possible, though some like Dwarven Crafting a Mithril weapon does not make sense.

**Normal Weapons** are common fare of weapons most characters have. They are the norm against which all others are compared. A broken weapon can be re-forged with no additional materials cost.

**Cold Forging** refers to a special process of making a weapon without the aid of fire. Without the tempering of the metal it is weaker and does not hold an edge well, therefore it suffers a -1 Damage Bonus. These weapons have a special effect on some characters, which the player must find out in-game. A Cold Forged Shield has no special qualities. A broken Cold Forged weapon can be re-forged with no additional materials cost. Cold Forging alone does not make a weapon an item of quality.

**Metal Coatings** allow a weapon to swing for that metal for 12 months – not Events – after its making. Eventually this coating will wear off and in 12 months – not Events – the weapon will be normal again. The metal to coat the weapon with must be available and is part of the stock material cost. Coated weapons are still considered

normal, not a weapon of quality. Copper, Silver and Gold coatings are the most common. A weapon with a Metal Coating can be re-forged if broken but without the coating. Mithril and Adamantite can never be coated with another metal nor can they be used to coat a weapon.

A **Dissection Knife** is constructed out-of-game as an edged throwing weapon, however, it can never be used in combat. Dissection knives are required to use the Dissection skill. They can be combined with other crafting skills, such as Elven and Dwarven crafting, and made of any metal.

**Wire Creation** is the ability to make wire from coins or stock. Each coin can make a 12 inch long piece of wire. The appropriate metal must be available to make the wire.

**Venom Weapons** are daggers or swords that have a special chamber in the pommel of the weapon that allows the character to load a contact alchemical item into the blade. Normally when a blade is coated with a contact alchemical item the next swing uses it up. The character can choose when to coat their weapon before they swing with the alchemical item, they suffix their damage with “Poison” when they swing. Only one dose of the alchemical item can be loaded at a time. Venom Weapons are far too intricate to re-forged and must be completely remade. Venom weapons are not marked in any special way and appear as normal weapons unless inspected closely.

Some rituals require a weapon or shield to be **Enchantment Quality** in order to hold the enchantment; this crafting creates such a weapon. This crafting does not change the properties of the weapon. The special property of the Enchantment Quality is lost if the weapon is broken and only the base normal weapon can be re-forged.

A weapon can be made **Permanently Alloyed** with Copper, Silver, or Gold with this crafting. The weapon must be created from scratch; an existing weapon cannot be Permanently Alloyed after its creation. This effect lasts until the weapon is destroyed. These weapons can be re-forged with no additional material cost.

A weapon smith can craft **Boxes** out of metal or wood of a maximum of 10 cubic feet. While not useful in and of itself, when combined with Dwarven Crafting and Dwarven Crafted Locks, characters have a safe place to keep their in-game belongings.

**Bone Crafting** allows the character to make a weapon out of the bones of a mystical creature that has Damage Resistance: Silver or better. The bone weapon will always suffer a -1 Damage Bonus penalty and can **never, ever** be combined with any other crafting skill except Enchantment Quality.

**Unshatterable or Dwarven Crafted** weapons and shields cannot be broken. They are not affected by the *Shatter* or *Blast* spells or the Shatter Weapon skill. They cannot be broken with any Strength Bonus. This does not mean they are indestructible. Anything that would melt a normal weapon will destroy an Unshatterable weapon. These weapons cannot ever be re-forged once destroyed.

**Elven Crafting** give a weapon a +1 **Damage Bonus**. This crafting can be combined with any other crafting including Mithril weapons. Once broken, the weapon can be re-forged but will not retain its Damage Bonus and the base cost must be repaid to regain the bonus. Elven Crafting a shield gives no additional bonus.

Weapons and shields can be forged with Mithril. These **Mithril Forged** weapons and shields are indestructible and nothing short of an Eldritch attack will harm these weapons and shields. Mithril ore is mined like any other ore and smelted into bars; however unlike mundane metals, once forged into something, Mithril can never be re-

forged. There are different types of Mithril – normal Mithril, Starfire Mithril, Moonfire Mithril, and Sunfire Mithril. Under starlight, Starfire Mithril gains a +1 Damage Bonus and is magical, Moonfire gains the same properties under moon light and Sunfire gains the same bonuses under sunlight. Mithril Forged weapons that have a wooden haft such as axes, hammers and polearms are assumed to have Unshatterable hafts and therefore the entire weapon is Unshatterable, this adds no extra time or cost and is assumed to be calculated in already.

	Weapon or Special Crafting	Production Time
Rank 1	Small and Thrown Weapons	10 Minutes
	One-Handed Blunt	15 Minutes
	Bastard Blunt	20 Minutes
	Two-Handed Blunt	20 Minutes
	Spear	15 Minutes
	Quarterstaff	10 Minutes
	Shield	15 Minutes
Rank 2	One-Handed Edge	15 Minutes
	Bastard Edge	20 Minutes
	Two-Handed Edge	20 Minutes
	Polearm	25 Minutes
	Bow	20 Minutes
	Crossbow	25 Minutes
	Cold Forging	Base Weapon Time
	Metal Coating (Copper, Silver, or Gold)	15 Minutes*
	Dissection Knife	15 Minutes
	Wire Creation	10 Minutes
	Rank 3	Venom Dagger
Enchantment Quality		Base + 20 Minutes
Permanently Alloyed Weapon		Base + 20 Minutes
Boxes		10 Minutes
Locks		15 Minutes
Rank 4	Bone Weapon	Base + 50 Minutes
	Venom Sword	50 Minutes
	Unshatterable (Dwarven Crafting)	Base + 30 Minutes
	+1 Damage Bonus (Elven Crafting)	Base + 30 Minutes
	Mithril Forging, Any Type	Base + 30 Minutes

\* The time given is for coating an existing weapon.

**Special Armor Smith Rules**

The player should review the armor section in Chapter 6: Combat.

The Armor Smith skill is purchased in ranks. Each rank allows the character to repair 6 Armor Points worth of cloth, leather or metal armor. Additionally the character can make a piece of leather or metal armor worth up to 6 Armor Points per purchase of the skill. When creating a new piece of armor the character must have the appropriate amount of stock material. This material is purchasable in-game from the Armory Guild or out-of-game from the Treasure Manager.

In between Events, the character can create any number of pieces of armor up to the number of Armor Points their skill allows. The player should see the Treasure Manager to get the cards made. If the character wishes to make the armor in-game they must spend the indicated time roleplaying the creation of the armor. All special armor types must be made in-game.

The chart below indicates the sectional armor pieces a character can make and the times associated with its creation. Additionally, there

is a Base Time needed to make any set of armor, whether it is one piece or a whole suit. These times are cumulative, so if the character wishes to make a piece of light plate chest armor (16 minutes) with shoulders (4 minutes) and sleeves (4 minutes) that covers the groin and thighs (8 minutes), the total time would be 72 minutes. The time spent must be uninterrupted, but does not require concentration to complete. If the character is forced to stop their work, the task fails and the stock materials lost. The character may talk to other characters or move around the forge performing the forging. They may cast spells, fish an item out of a pouch, or perform other simple tasks, but not engage in combat for more than 30 seconds or move more than 20 feet from the forge.

Armor Type	SL, RL, RM	CM	LP, HP
Base Time	20	30	40
Helmet, Full	4	6	8
Helmet, Partial	4	6	8
Helmet, Cap	2	3	4
Neck	2	3	4
Shoulders	2	3	4
Breast Plate	4	6	8
Back Plate	4	6	8
Upper Arms	2	3	4
Elbows	2	3	4
Lower Arms	2	3	4
Groin	2	3	4
Upper Legs	2	3	4
Knees	2	3	4
Lower Legs	2	3	4

Note: Abbreviations stand for: Soft Leather, Ridged Leather, Ring Mail, Chain Mail, Light Plate and Heavy Plate respectively.

Besides the raw material, the character needs access to a forge. In the City of Avalon, the Armory has a forge but the character must learn in-game what is required to gain access to the forge.

Armor Smith, like Weapon Smith, has special crafting techniques that give armor a special quality. All crafting must be done at the time the armor is made. Four purchases of the Armor Smith skill is needed for Eleven Crafting, Dwarven Crafting, Bone Crafting, and Enchantment Quality. Five purchases of the Armor Armor skill is needed for Mithril Crafting.

Armor Special Crafting	Production Time
Elven Crafting	50%
Dwarven Crafting	50%
Bone Crafting	50%
Enchantment Quality	25%
Mithril Crafting	50%

The times given in the above table are in addition to the time it would normally take to make the armor and are cumulative. For example, it would normally take the character 42 minutes to make a chain mail shirt that covers the torso and shoulders. If it was to be made Dwarven Crafted, it would take the character 63 minutes. If it was Elven and Dwarven Crafted, the total time would be 84 minutes.

There is little use in-game to make a shield using **Cold Forging**. This crafting alone does not make a shield an item of quality and therefore cannot be used to stop spells.

**Elven Crafting** a suit of armor increases the amount of Base Armor Points, the Armor Points without the Real Bonus, by 25%.

**Dwarven Crafting** a suit of armor makes the armor more durable, and therefore degrades, after taking damage, by 2 Armor Points instead of the normal 3 Armor Points.

**Bone Crafting** allows the character to create a suit of armor out of the bones of a character that has Damage Resistance: Silver or greater. The armor always counts as Chain Mail. This crafting cannot be combined with any other armor crafting except Enchantment Quality.

Some rituals require armor to be **Enchantment Quality** in order to hold the enchantment; this crafting creates such a piece of armor. This crafting does not change the properties of the armor. The special property of the Enchantment Quality is lost if the armor is broken and only the base normal armor can be re-forged. Armor that is Eleven Crafted, Dwarven Crafted, or Mithril Crafted is also considered Enchantment Quality.

**Mithril Crafting** allows the character to make a piece of chain mail, light plate, or heavy plate armor out of Mithril. This increases the Base Armor Points by 50%, the armor degrades after taking damage by 2 Armor Points instead of the normal 3 Armor Points, and makes the armor indestructible and nothing short of an Eldritch attack will destroy the armor. However, this does not mean the armor cannot be damaged during a fight. The same rules apply for Mithril armor, but the suit itself cannot be destroyed. Mithril ore is mined like any other ore and smelted into bars; however unlike mundane metals, once forged into something, Mithril can never be re-forged. There are different types of Mithril – normal Mithril, Starfire Mithril, Moonfire Mithril, and Sunfire Mithril. All these different types of metals work the same as standard Mithril when made into a suit of armor.

## Earning Build and Leveling

A “Level” is an overall indicator of how much adventuring a character has done. There are skills that characters cannot learn until they have achieved a certain Level; also, the strength of the monsters and the amount of treasure awarded on modules often depends on the average Level of the characters in the party.

A character’s level is determined by the number of Build Points they have been awarded **not** on the number of Build Points **spent**; your character can earn 20 Build Points and go up two Levels, but you may choose to spend only 2 Build Points on new skills.

**New characters receive 25 initial Build Points.** The **Awarded Build** is the number of Build Points you gain above that initial 25. The **Total Build** is the sum of the awarded Build Points plus the initial 25. The number of Build Points that corresponds to a character’s Level is on the following chart:

Level	Awarded Build	Total Build
1	0-9	25-34
2	10-19	35-44
3	20-29	45-54
4	30-39	55-64
5	40-49	65-74
6	50-59	75-84
7	60-69	85-94
8	70-79	95-104
9	80-89	105-114
10	90-99	115-124
11	100-109	125-134
12	110-119	135-144
13	120-129	145-154
14	130-139	155-164
15	140-149	165-174
16	150-159	175-184
17	160-169	185-194
18	170-179	195-204
19	180-189	205-214
20	190-199	215-224

Every character is awarded a blanket number of Build Points for attending an Event. **These Build Points are an award and not a right.** A player pays to attend the Event not for Build Points. The Builds Point awarded every Event is a privilege not a right and the Executive Board can chose to withhold Build Points from a character or the game if they wish or award extra Build Points if they wish.

The standard amount of Build Points awarded is given in the table below. In addition to the Build Point blanket, a player may wish to spend Brownie Points to increase this amount at a rate of 1 Brownie Point per 0.1 Build Points, up to a maximum of half the Awarded Build Points, rounded up. A player may also purchase Build Points for their characters. Only 10 Build Points per character per calendar year can be purchased. The player can buy Build Points in any amount up to the maximum in 1 Build Point increments.

Character Level	Awarded Build Points	Maximum Build from Brownie
1	6	3
2	5	2.5
3	4	2
4	3	1.5
5 to 25	2	1
26 to 30	1.7	0.9
31 to 35	1.5	0.8
36 and up	1	0.5

Characters can also gain extra Build Points for exceptional roleplaying and going on a Module. These extra Build Points are called Roleplaying Chips (RC) and are either written directly on a character’s card or handed to a player in the form of a round yellow chip. These chips are handed into Logistics at the end of the Event when you turn in your Character Card. Players earn RC not characters and a player may hand in the chips with any character they have; however, RC’s written on a character card are for that character only and cannot be transferred.



## Learning and Teaching Skills

Some skills have a prerequisite listed in the skill tables. This means that a character must know the prerequisite ability before they can learn that skill. For example, the Set Traps skill on the Rogue Basic Career Skill List has a prerequisite of Disarm Traps; a character must have the Disarm Traps Skill listed on the front of their Character Card before they can learn the Set Traps skill. **Both a skill and its prerequisite cannot be learned during the same event.** If your character has just learned Rank 1 of the Aura School of magic, you must wait until the next event before you can learn Rank 2 of the Aura School. **The character must actually know the prerequisite skill; it cannot come from an item.** For example, if a character has an item that gives them one Proficiency skill while worn, and they do not know the Proficiency skill, they cannot learn the Stun skill.

Most skills are gained only if a teacher can be found in-game. A teacher is not needed for the skills purchased with the initial 25 Build Points. A teacher is also not needed to learn an additional use of a skill from the Basic Skill Lists a character already has **provided they have purchased that Basic Career Skill List.** For example, if your character knows Weapon Proficiency +1, you can teach yourself Weapon Proficiency +2; if you have one use of the Disarm skill, you can gain a second use without a teacher; if you have purchased Power Points, you do not need a teacher for more. However you cannot teach yourself the next rank of a skill and must find a teacher in-game. For example, you cannot teach yourself Rank 2 of the Auras School or Rank 2 Weapon Smith.

**A teacher is needed to learn any skill off of a Basic Career Skill List if they have not purchased that list and a new Advanced Career skill even if the character already knows skills from that list.** Also, a teacher is needed to learn Miscellaneous Skills, but there is no list associated with these skills. **Further, a character has to be Level 5 before they can learn any Advanced Career skill.**

Normally, a character may learn as many skills as they want and have the unspent Build Points for. **However, only one new Advanced Career skill, including Master Miscellaneous, can be learned an Event.** If you are learning another use (an additional purchase) of a skill you already have, that does not count towards your one new skill. Limitations on learning ranks and prerequisites still apply.

There may be other restrictions to learning skills. For example, magic spells can only be taught with the aid of a Tome of Spell Lore. The Duchy of Avalon has many tomes available to characters in the City of Avalon. Those ranks listed as available on the Mage Basic Career Skill List can be learned using these books.

When a character is taught a skill, the teacher must write the following on the back of the Character Card: the name of the new skill, and the teacher's name and the teacher's Player Number. Aside from the exceptions noted below, anyone can teach any basic skill they know. Advanced Career skills require the teacher to have the Teach skill. There is a Teach skill for each Advanced Career and each must be learned separately. A character can teach any skill they have the teach skill for to any character that has the proper prerequisites to learn that skill." The Teach skill does not cost any Build Points but the player must have Plot approval to gain this skill. Additionally, any Master Miscellaneous skills the character has can be taught; a separate teach skill is not needed. The one exception to this rule about Advanced Career skills is Elemental Pool Points and Spell Singing Points, a character can teach themselves both without the Teach skill once they learn the first ones.

Players teaching a skill should roleplay the instruction and not just sign the Character Card. As a rule, it takes 5 minutes per Build Point

of roleplaying to teach a skill. So, to teach the First Aid skill would take 10 minutes, to teach the Slay Skill would take 50 minutes. However, some teachers may choose to take longer to teach a skill and others may have a skill or ability that will allow them to reduce the time it takes to teach a skill. Spending the time to roleplay the teaching will make the new skill more significant to the student. However, the student does not gain the use of the new skill until the next Event; characters do not suddenly gain the ability to pick locks at the instant the teacher signs their card.

**In addition to the in-game teaching of the skill, the teacher will instruct the player out-of-game how the skill works.** If the player teaches the out-of-game use of the skill incorrectly, they may lose the ability to teach.

Once a teacher signs the card, it is assumed they have taught the skill correctly. If a player wishes their character to teach a skill incorrectly then they should not sign the card.

Once a skill appears on a player's card their character has used the skill or cast the spell successfully at least once.

## Body Points

Body Points reflect the ability of the character to take damage. It is a measure of their hardiness and stamina in battle. A character with a low number of Body Points is more grievously affected by the damage they take than a character with an exceptionally high number of Body Points.

The LAIRE Logistics system is computerized, and a character's Body Points are calculated before the Event. The number of Body Points a character has is indicated on the Character Card. The complete procedure for determining a character's Body Points is given below. If a discrepancy is suspected between the number of Body Points on a Character Card and what is expected the player should report the problem to Logistics.

Body Points are calculated in a way that reflects how a character decides to spend their Build Points. The skill system is divided into different lists, and these lists are grouped into six categories. For each skill purchased, a fraction of a Body Point is received depending on the category of the list; the sum of these fractions gives the base number of Body Points. Another 3 Body Points are added to this base, and any remainder in the grand total is then rounded up to the next whole number. Finally, any racial or other special bonuses or penalties are added to the total. This gives a character's Body Point total.

There are five categories of Skill Lists: Martial, Dexterity, Arcane, Faith, and Racial. Miscellaneous skills fall into one of the first three categories. Each Skill on one of these lists will give you a different amount of Body Points per Build Point. See the table below for the values:

Skill List Category	BP per Build Spent	Associated Skill Lists
Martial	0.25	Warrior Basic Career Skill List Weapons Master Skill List
Dexterity	0.10	Rogue Basic Career Skill List Master Thief Skill List Assassin Skill List
Arcane	0.05	Mage Basic Career Skill List Alchemy Skill List Sorcery Skill List Warlock Skill List Spell Singing Skill List
Faith	0.20	Follower of the Light Skill List Druid Skill List Servant of Darkness Skill List
Miscellaneous	0.15	Some Miscellaneous Skills Some Master Miscellaneous Skills
Racial	0.15	Racial Skills

There is one exception of the on-list versus off-list Build Point value, for Power Points, you receive 0.05 Body Points for each Build you spend, even if you bought the Power Points off-list.

Some skills are found on more than one Skill List; for example, the One-Handed Edge skill is on the Weapons Skill List and the Rogue Basic Career Skill List. You receive the Body Points from the Skill List that gives you the greatest number of Body Points, even if you purchased the skill from a different Skill List. In the above example, if you purchased the One-Handed Edge skill from the Rogue Basic Career Skill List, you would still receive 0.25 Body Points, as if you purchased it from the Warrior Basic Career Skill List.

*For example, Lilith purchases: the Weapons Skill List, One-Handed Edged Weapon, and Shield. All 18 Build Points are spent on Martial skills, Lilith gets  $18 \times 0.25 = 4.5$  Body Points, plus 3 = 7.5 = 8 Body Points.*

*Tythis purchases: One-Handed Edged Weapon (6 BP), Battle Surgery (4 BP), First Aid (2 BP), Armor Smith (3 BP), Literacy (4 BP), 1<sup>st</sup> Rank Aura School (5 BP), and 11 Power Points (11 BP). This sums up as follows:  $6 \times 0.25$  (Martial skills) +  $13 \times 0.15$  (Miscellaneous skills) +  $16 \times 0.05$  (Arcane skills) = 3.95 Body Points, plus 3 = 6.95 Body Points, which is rounded to 7 Body Points.*

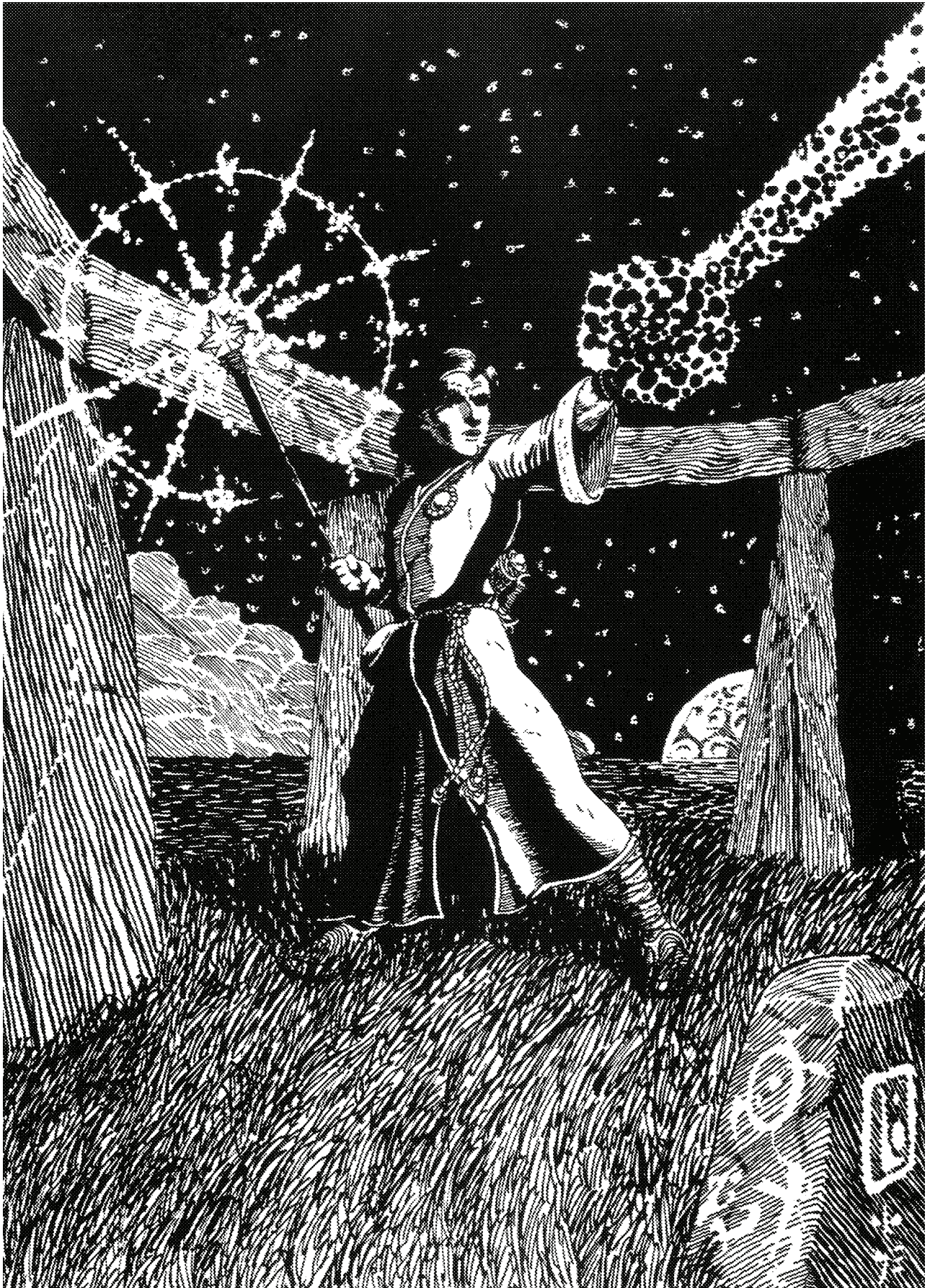





# Chapter 3: Magic...

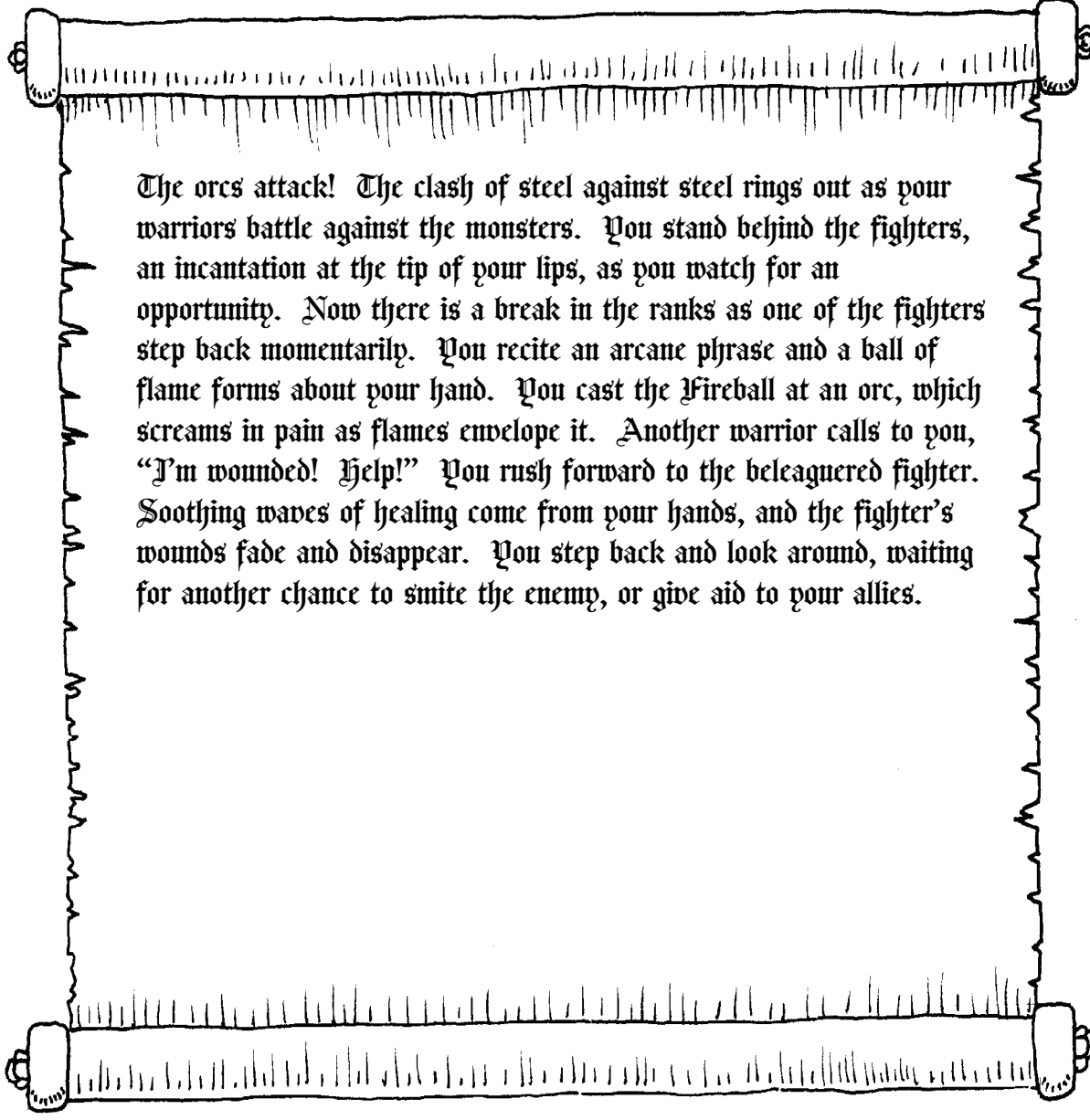

The orcs attack! The clash of steel against steel rings out as your warriors battle against the monsters. You stand behind the fighters, an incantation at the tip of your lips, as you watch for an opportunity. Now there is a break in the ranks as one of the fighters step back momentarily. You recite an arcane phrase and a ball of flame forms about your hand. You cast the Fireball at an orc, which screams in pain as flames envelope it. Another warrior calls to you, "I'm wounded! Help!" You rush forward to the beleaguered fighter. Soothing waves of healing come from your hands, and the fighter's wounds fade and disappear. You step back and look around, waiting for another chance to smite the enemy, or give aid to your allies.

Magic is an important element to any fantasy roleplaying game. Even if your character never casts a magic spell or uses a magic item, the existence of magic has an impact on your character. The LAIRE magic system has several aspects; the basic magic or low magic is described in this chapter. There are other, more complex forms of magic called high magic which is comprised of: Sorcery, Warlockery and Spell Singing. There is also the faith magic of the Druids called Nature Magic. These high magics are described in their respective Advanced Careers. This chapter deals solely with low magic and the various schools of magic that make it up, along with the general rules for how to use magic in our game.

## How Spells Work

The heart of any magic system is the spells that exist. In LAIRE, there are dozens of low magic spells; these are organized into schools according to the nature of the spell. To cast a spell, a player must recite a spell verbal, toss a small beanbag called a spell packet at a target, and hit the target. Each spell costs a certain number of Power Points; spell casters have a limited number of Power Points for casting spells. Spells may also be contained within items such as scrolls or magic items.

## Spell Casting 101

### How to Cast a Spell

These are the complete, formal steps necessary for a character to cast a spell:

- The caster must know the particular rank of the particular school to which the spell belongs. For example, to cast a *Kill* spell, a character must know Rank 4 of the Death School; knowing Rank 4 Charms School or Rank 1 Death School spells does not help.
- The caster must have an unbroken arm, a free, unfettered, undamaged hand with nothing in it in-game. Out-of-game, the only item that can be in the player's hand is a spell packet. So if a caster's wrists are bound, they can still cast, but not if their hands were broken, removed or restrained.
- The caster must recite the spell verbal loudly enough for at least one other person to hear. The target does not have to be able to make out the words or hear the verbal. However, if the only person that can hear the verbal is the target, then they must be able to hear the verbal. Therefore, in a battle, you may have to yell so your target can hear you. However, if you are alone you can still cast a spell on yourself or on an inanimate object.
- After the spell verbal has been recited, the caster must touch a target with the spell packet. The caster can hold on to the spell after reciting the verbal for no longer than 5 seconds. If the caster has not thrown the spell packet by then, the spell is wasted and the Power Points expended. While holding onto a spell, a caster can speak, "Get out of the way, I'm holding a Fireball" for example; otherwise they should be counting out the seconds by counting "One *Fireball*, two *Fireball*..." The caster will both count the seconds and remind others what the spell will do when it hits.
- For a spell to take effect, it must hit the target. It can hit any part of the target, any item of clothing that the target is wearing, or any item that the target is holding, including a

shield; regardless of whether the item is in or out-of-game. The one exception is the head, which is never a legal target for any physical contact in-game. While not a legal target for melee combat, the hands and groin are legal targets for spell packets. If the packet bounces off the ground or is deflected in some other way, by a tree branch for example, the spell does not affect the target. Also, a spell can affect an unintended target; if a caster throws a *Lightning Bolt* spell and a friend steps in and is hit by mistake, the caster cannot cancel the spell.

- If the spell does damage, the caster must call out the damage when the packet hits the target. For example, if a caster hits someone with a *Fireball* spell, the caster should say "Fireball, Sixteen Magic Fire" when the spell hits; if a caster hits someone with a *Maim* spell, the caster should say "Maim, Twelve Magic Body" when the spell hits. The proper form therefore is: spell name + damage + type of damage. If the spell does not deal damage, then simply the name of the spell is used unless the spell requires a choice to be made as in what limb is affected or what spell is affected. For example, casting an *Enslavement* spell at a target the caster would say: "Enslavement Spell". The caster should never call extended damage; that is, if they think a character takes double damage from fire, they should not call "Fireball, Thirty Two Magic Fire" if they hit with a *Fireball* spell, since this may confuse the player playing the target character.

A character always needs to have a spell packet to cast a spell, unless they are casting a spell upon themselves. Even if their intended target is unresisting, they must touch them with a spell packet. A character cannot physically restrain another player in order to cast a spell or for any other reason. For example, a player cannot grab another player's arm and cast a spell. A character cannot cast a spell on an opponent they are in combat with by touching them with a packet; they must throw the spell packets when fighting. This is also true for characters with claws – either the natural ability or the skill. **A character with claws can never "touch cast", in combat or out, with their claws. A character cannot use the Channeling skill with claws, no matter how big or powerful or magical the character is, their claws ARE NOT weapons of quality. This does not mean there are not creatures that have spell like abilities that they deliver with their claws.**

The target player is often a poor judge of whether a spell packet hit them. When someone tosses a spell packet at a character, they are often trying to dodge the spell or trying to run away; a spell can hit someone from behind or be tossed at them while it is dark. The spell caster or other people are usually in a better position see if the character has been hit. **As a general rule, if at least two people say you have been hit by a spell, assume you have been hit and keep on playing.**

### How to Interrupt a Spell or Fail to Cast a Spell

The Power Points required to cast the spell are spent at the end of the spell verbal, so if the spell casting process is interrupted in any way, the spell has no effect and the Power Points are not lost unless the caster has completed the verbal but not yet thrown the spell. If the character flubs the spell's verbal the spell fails and the Power Points are lost, but if the character catches themselves before the verbal is completed they can stop reciting or change to a different spell verbal. The ways a spell can be interrupted are as follows:

- The caster takes damage to their Armor Points or to their Body Points, either by being struck by a weapon or by another spell. The only ways a caster can continue casting a spell while taking damage are: to call an appropriate defense or by having the Concentration skill. It is acceptable to finish the spell verbal then call a defense even if this breaks the 5 second rule on calling defenses.
- The caster is unable to speak or move, for example, by being affected by a *Silence* or *Paralysis* spells, or is unable to move their hand.
- The spell verbal is recited incorrectly. Any mistake means the spell does not work, even if it is a single word. Note that invoking a latent spell while reciting a verbal is *not* a mistake.
- The spell packet leaves the caster's hand before the verbal is fully recited.
- The spell does not come into physical contact with a target. If the target of a spell is a character, then the spell can affect them or any item in their possession that can be seen; if a fighter is carrying a sword, then a *Shatter* <sword> takes affect if the spell hits the fighter, the sword, or any item they are holding. Spell casters often aim their offensive spells at an opponent's shield, and some fighters may drop their shield rather than risk being affected by a spell. However, if the spell is *Blast* <shield> and the spell hits the shield, then the shield is broken since the shield is a legitimate target of the spell. Some shields of quality can resist elemental damaging spells. See later in this chapter for a full description.
- The spell packet strikes the target character in the head. For safety reasons, the head is never a legal target for a spell packet.
- The caster does not have a spell packet to throw. It is the responsibility of the player to make sure they have enough spell packets. A player may **not** call a Hold to collect spell packets. However, if a Hold is called for some other reason, it is allowed to collect packets as long as the Hold is not prolonged and as long as the player returns to their exact position when the Hold was called.

### Power Points

Power Points of any kind, low magic, Spell Singing, or Elemental Pool Points, are a measure of the amount of magical energy a character has. A spell caster receives a certain number of Power Point tags with which to cast spells based on how many Build Points the character has spent learning Power Points. These tags are given to the player when checking in at Logistics. These tags should be kept on a ring with the player's other tags. Power Point tags are color coded; on a given Tag Cycle, a spell caster is only allowed to use those tags whose color has been assigned for that Tag Cycle.

When a character casts a spell, the player removes the appropriate Power Point tags from their ring. If the spells were used against another character, that player has the right to ask for the used Power Point tags as proof that the caster had enough power to cast the spell; otherwise the tags should be given to a Marshal or discarded. If the Power Points were used to cast a latent spell, the caster should write their out-of-game name and the name of the latent spell on the back of the tags and give the tags to the character receiving the spell; the target should put the tags on their ring so they can prove that they

have the spell when they invoke it. Often the character casting the latent spells will be in a fight or some other intense activity, during the action, it is not necessary to stop what is going on to write tags, but the player should keep track of what they cast and be ready to turn the tags over to the appropriate person when the action is over.

Power Points may not be traded between characters. They cannot be saved from day to day or from one Event to another. If, at the end of the Tag Cycle, a player has unused Power Point tags, they must be turned into Logistics at the end of the Event.

### Spell Verbals

In order to cast a spell, a player must recite a spell verbal, that is, a short phrase that uniquely identifies the spell to be cast. When a spell verbal is recited, each word must be distinct enough for at least one person to hear; "Isummrfrth nelldrich furlb!" is not a substitute for "I Summon Forth an Eldritch Fireball."

All the spell verbals for a rank within a school of magic begin with a common phrase; the name of the spell completes the verbal. For example, the spells of the second rank Aura school have verbals that begin with, "I Weave a Protective Aura of..." So, to cast a *Negation* spell, a player would say, "I Weave a Protective Aura of Negation." Similarly, the verbal for the first rank Charm school is, "I Command You to..." so to cast a *Speak the Truth* spell a player says, "I Command You to Speak the Truth."

A caster may always use the phrase of a higher rank to cast a spell of a lower rank. For example, "I Weave an Aura of Armor," "I Weave a Protective Aura of Armor," and "I Weave a Protective and Warding Aura of Armor" are all legitimate verbals for the *Armor* spell, a first rank Aura spell. However, "I Weave an Aura of Invulnerability" is not a valid verbal for the third rank *Invulnerability* spell; only "I Weave a Protective and Warding Aura of Invulnerability" is valid.

The spell verbal is in-game. If you see a player with a spell packet in their hand start to recite, "I Control Chaos..." then your character knows that the spellcaster is about to cast a Necromancy spell; if you hear "I Summon Forth..." then you know that a Pyrotechnics spell is about to be cast.

There are other in-game characteristics that distinguish spells from one another. Each spell gives off a flash of light when it is cast. The table below indicates what color goes with what school.

School	Color
Auras	Green
Bonds	Dark Blue
Charms	Yellow
Death	Gray
Demonology	Black and Aspect Color
Enchantments	Orange
Healing	Rosy/Pink
Ice	Light Blue
Necromancy	Black
Pyrotechnics	Red
Thaumaturgy	Purple

However, it takes more than just saying the words to cast a spell. A character who just says, "I Call upon Darkness and Terror to Kill You and Wreak Havoc upon Your Soul," has not necessarily cast a *Kill* spell; they must have the skill of Rank 4 Death Magic, spend the Power Points, have a spell packet in hand, and the desire to cast as well. Any character can say the verbal for a spell if they know them,



even a character with that school and rank of magic, but the spell is not cast unless the character wishes to; there needs to be a conscious effort on the part of the character to cast a spell. The spell is cast when the verbal is finished, so there is a visible effect when the character ends casting.

Players should avoid using the verbal for spells or the out-of-game skill activation descriptors in-game unless they are actually using that skill or casting that spell. A player cannot gain an unfair advantage by using an in-game spell or skill verbal.

*For example, Greg is playing an NPC rogue that has no magic. Before he leaves the NPC cabin he picks up a spell packet. Later, after being discovered, he is chased by some characters out of the inn. Greg tries to get away by scaring the characters by turning, with spell packet in hand, and recites the Death Slave verbal and pretends to throw the spell packet. His character cannot cast magic, but the players chasing him do not know that and assume, incorrectly that a very dangerous spell is coming at them and act appropriately. This gives Greg an unfair advantage by using an in-game spell verbal to fool other players.*

*Another example, Brian is playing an NPC Dark Paladin. He comes into the inn and begins telling the characters there about how his farm house was attacked by Dark Paladins. Many characters come over to listen. During the tail, he says, "Yeah and they said 'By the will of the Dark Lord I grant you DEATH!' and reaches over and uses his Death Touch skill to attack another character. No one can be sure what happened. This is taking an unfair advantage of the rules. However, had Brian gotten everyone's attention, then turned and said, "And I am that Dark Paladin, 'By my black heart I grant you DEATH' and used the skill on another character, that would be acceptable.*

## Special Rules for Spells

### Latent Spells

Not all spells have an immediate effect. Some spells give the target character the ability to hold on to a spell and to invoke it when they need it. These delayed action spells are called latent spells. Latent spells are identified as such in the spell descriptions.

The *Negation* spell is an example of a latent spell; when a character invokes it, this defense cancels another spell that was just cast on the character. A character with such a latent spell cast on them can choose when the spell is to take effect. If someone casts a Healing spell on them, the character probably will not want to invoke a *Negation* spell; if someone casts a *Kill* spell on them, they probably will.

To invoke a latent spell, the player says the name of the spell. This is out-of-game; a player can do this even if their character cannot

speak. In-game, there is a characteristic flash of light that indicates the use of a latent spell. An unconscious, sleeping, enfeebled, or Torso Stunned character cannot invoke a latent spell, nor can inanimate objects or a mindless creature such as a Zombie. Some latent spells do not need to be invoked out loud, nor do they all have the characteristic flash of light. One example of this is the *Resist Suggestion* spell. The player does not need to say anything in order to invoke the use of this defense, but they should give the tags to a marshal or the player – their choice – and explain why they did not take the effect of the spell.

A latent spell must be announced when it is used. If the player forgets they have a defense, too bad; there are no do-overs. Latent spells can only be used once. If a latent spell is invoked by mistake – for example, a player says "Invulnerability" when they meant to say "Negation" – then the spell has been used. **If a player is not sure what kind of spell defense to call for the attack, they may ask the attacking character what kind of attack it was, either physical or magical.** This is the limit to the information given. If the player is still not sure, they may call as many defenses as they wish, but they must be called at the same time, all the defenses called are used, and the player will find out at the end if the attack was stopped or not.

*For example, Errol is fighting a Basilisk which tries to turn him to stone. The player asks what kind of attack it is and the NPC responds with "Magical". Still not sure what he should call, Errol decides to call: "Negation, Spell Shield, Dodge!" All three defenses are used up and since one of the defenses worked the NPC tells Errol that the attack was stopped.*

**The player has 5 seconds in which to call a defense.** After this time, they forfeit their chance to call one. One exception to this is calling a spell defense while casting. It is acceptable to call a spell defense when the character finishes reciting the verbal. **In order to call a spell defense, the character must have the spell already cast upon them before they are affected by a spell. You cannot use the 5 second window to cast a spell upon yourself in defense of that attack.**

Latent spells cast on a character are attached to a character's body, not to their spirit. If a character dies and they are resurrected at the Healers Guild without their body, then they lose all the latent spells



that were cast on them in addition to any alchemical items they may have had active when they died.

When casting a latent spell on a character, take the Power Point tags used to cast the spell, write the caster's name and the name of the spell, and give the tags to the character. For convenience, a player may abbreviate the name of the latent spell. Here are some suggested abbreviations:

Latent Spell	Suggested Abbreviation
Absorption	ABS
Armor*	+3 AP
Aura of Resistance	ARES
Defense	DEF
Fire Shield	FS
Fortitude	FOR
Giant Strength	GS
Frost Brand	FB
Ice Shield	IS
Invulnerability	INV
Magic Weapon	MW
Negation	NEG
Obscure	OBS
Reflection	REF
Resist Suggestion	RS
Stamina*	+3 BP
Vigilance	VIG

\* These spells are not actually latent, but are active spells. They are in the list for completion.

Latent spells do not last past the end of the Event. When the Event is over, discard the Power Point tags used to represent the latent spells cast on your character or weapons.

### Stacking Spells

There can be no more than one of any given spell active on a character at any one time. A character cannot have three *Giant Strength* spells, be *Dominated* by two different spell casters, or have seven *Reflection* spells on them at the same time.

There are also some spells that cannot be cast in combination with other spells. For example, a character cannot have both a *Negation* spell and a *Reflection* spell cast on them. All of these limitations are listed in the descriptions of the individual spells.

If a character has a spell cast on them and they already have an incompatible spell, then in general the spell that uses the greater number of Power Points takes precedence; if the two spells have the same number of Power Points, then the more recently cast spell takes precedence. This is just a general guideline; there may be exceptions noted in the school and spell descriptions.

Note that these guidelines relate to spell *incompatibilities*, not spell *defenses*. A *Negation* spell will cancel a *Kill* spell, even though the *Kill* spell uses more Power Points.

The exception to this rule is the Warlock skill Overlay. This skill allows a character to have more than one of the same type of defensive spell on them. For example, a person could have a *Negation* and an *Overlaid Negation*. See the skill description for the Overlay skill for more information on this.

### Wall Spells and Concentration Rules

Wall spells, such as the *Wall of Flame* or *Wall of Force* spells, diverge from the normal rules for casting a spell. The caster must have physical representation for the spell in lieu of a spell packet.

The caster should recite the verbal for the spell following the normal rules for verbals and how long the caster has to release the spell. However, rather than throwing a spell packet the caster takes a piece of garland, of any color except green, that is 10 feet long and **in-game** roleplays drawing the wall while out-of-game they place the garland down. The player may not call a Hold to place the garland down and should their spell be interrupted before the garland is placed or they fail to place the garland down before 5 seconds after the end of the verbal has expired; the spell and the Power Points are expended. The character cannot throw the garland; they must place it down with their hand. The garland cannot be attached to anything such as sticks, weights, or weapons. The garland cannot be "pre-placed" and must be placed while casting.

The caster may lay the garland in any shape they wish, but care should be taken that the caster is not immune to their own wall spells. The caster can place the garland in a line, an oval, a semicircle, a right angle, etc, whatever shape they wish. The garland can only touch itself at the end points; doubling the garland back does not double the damage. For example, a character wants to fill a 5 foot wide doorway with a *Wall of Flame* spell, they can make a narrow oval or a "U" shape but anyone passing through will only be effected once by the wall and hence only take 14 points of magical fire damage.

The garland is always out-of-game, so a character cannot move it in-game. Once the wall spell ends for any reason, the garland can be picked up or moved out of the way, but no Hold should be called to do this. If any character wishes to cast a wall spell where there is garland already placed from a previous casting of a wall spell no longer than 5 minutes prior, but not in use, they can, but they must still roleplay drawing the wall by moving their hand over the garland from end to end. One piece of garland can only represent one wall at a time; three casters cannot use the same piece of garland for three separate wall spells. Additionally, walls cannot overlap and the garland must be at least 5 inches apart.

Wall spells are always vertical and parallel to the radial axis of the Earth. It can never be placed on an angle or parallel to the surface of the Earth. The wall is always 10 feet high and will always follow the contours of the natural terrain features of the ground it is cast upon. So if the wall is placed on a slope with a big rock in the way, the wall will be 10 feet high all along the path and look like the diagram to the right.

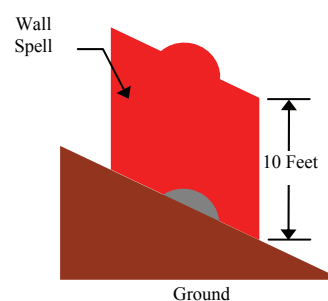

If the wall spell goes over a body or inanimate object, the wall spell will go through the object, and since damaging spells causes no damage to inanimate objects, there is no added effect. However, the *Wall of Force* spell works slightly differently. It still goes through the object but that object is locked in place and cannot be moved until the spell ends. If the object is a character or a character in their Death Count, then the player must choose what side of the wall they want to be on and can move appropriately.

In order to maintain the wall spell after it has been cast, the character must concentrate on it. To represent this concentration, the player should hold their arm – either one – out straight, perpendicular to their body and parallel to the ground with their palm facing the wall they are maintaining. If the caster's arm is no longer perpendicular to their body, for example, the player gets tired, then the spell has expired. **The caster may not rest their arm on any support.** These spells do not require total concentration and the character may move at a walking pace attack, block, call skills, invoke latent spells, or cast new spells so long as the new spell is not also a concentration spell. However, the character must maintain Line of Sight with the wall they are maintaining and cannot take any damage to their Armor Points or Body Points; be affected by any spell or effect, other than the *Pin* spell, that restricts movement; or any spell or effect that causes a Torso Stun. The caster must also remain awake; sleeping spell casters cannot concentrate on maintaining a spell.

All wall spells are not opaque and thus a character can see through the wall. Characters can maintain Line of Sight through these walls. Each wall can be seen as they glow with the color of their school.

### Durations

Spells do not last forever. Each spell has a duration given in its description. Some spells have a fixed time limit; for example, a *Sleep* spell lasts for 10 minutes. Other spells have a duration of Instant, which means the spell has an immediate effect.

Other spells last until the caster leaves Line of Sight. This means that the caster would be able to see the person or area affected if the player were to turn around or to take a step. If someone steps between the caster and the target, this will not block the spell; if the caster walks around to the other side of a wall then the spell expires. The spell also expires if the caster is Unconscious, Bleeding to Death, Mortally Wounded, at the Brink of Death, or Dead.

If the duration of a spell is listed as Event, then the spell lasts to the end of the current LAIRE Event.

Latent spells last until they are invoked.

All spells, including latent spells, expire at the end of an Event. Spells do not carry over from one Event to another.

Note that the above rules deal with the duration of *spells*. These rules do not apply to the duration of *curses* or any other forms of magic that affect a character's spirit; such magic can last indefinitely. Some sorcery effects also last longer than one Event. These times are given in the ritual's description.

### Overspending Power Points

A character cannot ever overspend Power Points. This is true for low magic Power Points, Spell Singing Points, Elemental Pool Points, Healing Pool Points or Wounding Pool Points. If you do not have the power to use, you cannot cast the spell or wield the effect. The spell simply fails and the balance of the points are not spent.

Should a player realize later that they have overcast, they should tell a marshal that is involved in the encounter and that marshal will make an appropriate call on what should happen. If there is no marshal available, and the issue is between a PC and an NPC, then the "tie" should go to the PC. If the issue is between PC's only, and no simple, reasonable resolution can be come to between the players, the players should find a marshal to resolve the problem.

*For example, Dennis is casting a Life spell on his sister Kaye. He correctly recites the verbal and the spell works. However when he looks at his*

*tag ring to hand over the Power Points, he realizes he only has 10 Power Points left. Kaye should lie down and resume her Death Count and Dennis still has his 10 Power Points.*

### Natural Immunities

Some races and creatures are naturally resistant or immune to the effects of some spells. You will have to learn about these immunities in-game; do not be surprised if a fire-breathing dragon ignores all the *Fireball* spells you cast at it.

Some races can only resist the effects of certain spells a limited number of times per day. If a player is playing a member of such a race, and they have both a racial defense and a spell defense, they must use their racial ability first. For example, if a character has both the Elven Resist skill and a *Negation* spell defense and someone hits them with a *Fumble* spell, they must call their Elven Resist first.

### Shields and Spells

Normal shields do not stop spells, and as stated before, if a spell hits a character's shield they are affected by the spell. Shields of quality, however, will stop damaging elemental spells. The shields of quality are: unshatterable shields, enchantment quality shields and magic shields. Even if the shield has been in the character's family for generations and is special to the character, unless it has the appropriate tag, it will not stop any spells.

The six elemental schools are given in the table below:

School of Magic	Element
Bonds	Earth
Death	Death
Enchantments	Air
Healing	Life
Ice	Water
Pyrotechnics	Fire

Only the spells from these schools that do damage are stopped by shields of quality. For example: the *Fireball*, *Ice Bolt*, *Lightning Bolt*, and *Maim* spells all do damage and are all stopped by shields of quality. Spells that have an effect are not stopped by shields of quality. For example: the *Pin*, *Paralysis*, *Shatter*, *Blast*, *Ice Cast* and *Artic Wind* spells are all effect spells and are not stopped by shields of quality.

### Stopping Spells for Someone Else

A spell that is not augmented by the Perfect Aim skill can be stopped for another character by using a martial parry skill. The character doing this still takes effect from the spell and has the option to call a defense that stops spells.

*For example, a necromancer throws a Death Slave spell at Mythies who does not see it coming. Hemist, standing within weapons reach of Mythies, uses his Critical Attack skill as a parry to stop the Death Slave spell. He then calls his Negation spell to stop himself from becoming a Death Slave.*

### Casting Spells on Inanimate Objects

In general, a spell may not be cast on inanimate objects such as rocks or weapons. You cannot cast a *Fire Shield* spell on a wooden box so that it cannot be burned, an *Obscure* spell on your magic sword so



that no one can tell it is magical, or a *Lightning Bolt* spell on a rock to destroy it.

There are exceptions to this general rule, and they are noted in the individual spell descriptions. Among these exceptions are: *Attachment* and *Lock* spells, which can be used to hold objects in place; *Shatter* and *Blast* spells, which can be used to destroy objects; or *Magic Weapon* spell, which makes a weapon magical for one strike. Under no circumstances can a spell be cast on an object more than once; in particular, a character cannot cast multiple *Magic Weapon* spells on a weapon, but they could have a *Magic Weapon* and *Frost Brand* spells on one sword, for example.

A Dying or Unconscious person is not an “inanimate object” for the purposes of these rules. A character can cast a *Sleep* spell on a person, give them a Killing Blow, cast a *Pin* spell on them, then cast a *Heal Life* spell; the result will be a *Pinned* character with 1 Body Point.

## Learning Low Magic

There are over 120 low magic spells in the game. The spells are divided into different schools of magic. A school of magic contains spells whose effects are all related in some way. For example, the Auras School only contains spells that help to defend a character; the Pyrotechnics School contains fire related spells.

Spells are also grouped by rank within a school; the more powerful a spell is, the higher its rank. What rank a character may learn is dependant upon the chart given below.

Rank	Character Level	Power Points
1	1 <sup>st</sup>	3
2	3 <sup>rd</sup>	25
3	5 <sup>th</sup>	50
4	7 <sup>th</sup>	75
5	9 <sup>th</sup>	100

All the lower ranks of a school must be learned before a higher rank can be learned; a character cannot learn the second rank of the Healing School unless they know the first rank of the Healing School.

The schools and spells are described in detail later in this chapter. A school may have special rules that override the standard rules on magic; a spell may have special rules that override the standard rules of the school. In order to understand all the rules that affect the use of a particular spell, you must read both the school description **and** the spell description.

When you choose a school of magic to learn, be aware that some schools of magic are illegal in some parts of the LAIRE game world. For example, the School of Necromancy is illegal in the lands of Avalon.

Though events in-game may change exactly how and what a character can learn, the norm is any character can teach any other character that has all the proper prerequisites and racial ability to learn the first rank of any school of magic they already know. This can be done anywhere and requires no special out-of-game supervision. While in the Guild of Arcane Lore or on another node of magic, a character can teach any second rank school of magic they know, without any aid. To learn any of the other schools and ranks in this rulebook, the character needs a teacher and use of the Magical Tomes located, usually, in the Guild of Arcane Lore. It is through these tomes that the knowledge is taught by the teacher to the student.

The Guild of Arcane Lore is one of the Guilds operating in Avalon, and there may be in-game requirements needed to gain access to these tomes. There are also other tomes that teach magic elsewhere in the world that the character must learn about on their own.

Some spells and ranks of magic are lost and cannot be found in the Magical Tomes Avalon currently has. There are currently no fifth ranks of magic in the Magical Tomes that Avalon currently has. The lost spells are indicated in the spell descriptions later in this chapter.

## Spell Books

There are many spell verbals in the game, and it helps to have a written reminder of what they are. However, no one is allowed to have an out-of-game cheat sheet of the spell verbals in-game. If a Hold is called, a player can use the opportunity to look at a reminder of a spell’s verbal. The spell verbals have to be memorized and reviewed in-game.

Many spell casters prepare a small in-game or in-play book that contains the spell verbals. This is optional, but it is strongly encouraged. Any book, sheet of paper, or other reference to the spell verbals is an in-game/in-play item. If a spell book is in-game, it can be stolen, used by others, or destroyed in-game. Out-of-game a player should never damage another players physical representation without that players permission; guard it carefully. There is no penalty for losing a spell book, except that the player has to find some other way to review the verbals for the spells. Of course, if a player memorizes every spell verbal in these rules, then they do not need a spell book. It is entirely up to the player.

If a player acquires someone’s in-game spell book and finds an out-of-game name inside, take the book immediately to the Merchants’ Guild. Out-of-game, if a player wants to get their spell book back by the end of an Event, make sure an out-of-game name is written on the book. If a player finds an in-play spell book, they may not take it, they can leave a note saying it was stolen and get a tag for that book from a marshal. It is the player’s responsibility to indicate in their spell books whether the book is in-game or in-play. A player should assume if the book is not marked, that it is in-play.

Even though a player may know a spell’s verbal, they still cannot cast it unless their character has learned the skill of casting the rank of the school to which the spell belongs. They may have memorized that the *Heal Person* spell has the verbal, “I Draw upon the Earth to Heal this Person,” but they cannot cast a *Heal Person* spell unless they know Healing Rank 1.

## New Spells

There are spells in the game that are not described in these rules. This means that even if a player memorizes all the spell verbals in the rules, a player may still be confronted with spells they do not know. If a player hears an unfamiliar spell verbal, they may call a Hold and ask what the spell does, but they should only do this if there is a serious question about the effects of the spell.

However, when the combat is over, a player should feel free to ask a spell caster for proof that they can cast an unfamiliar spell. Whether a spell caster is a player or an NPC, they must have proof that indicates what non-standard spells they can cast. Any spell that is not in this rulebook only exists because it has been approved by both the Plot Committee and the E-Board; a player who makes up spells without that approval will be disciplined.

It is possible for new spells, new ranks, and new schools to enter the game through research and ritual magic. A player must learn about these new schools and spells in-game.

## Schools of Magic Descriptions

The following pages contain all the Schools of Magic commonly available to players and some “common” lost ones as well. These schools and the subsequent spells in each rank can be learned at the Mages’ Guild. There are other means of learning magic: tomes, special scrolls, and special teachers. These methods may allow a character to learn a spell, rank or even a whole school not listed in this rulebook. The player must find these answers out for themselves in-game.

### Auras School

#### *Special Rules for the Auras School*

A character may only have one physical defensive Aura spell – *Vigilance* or *Invulnerability* – on them at any one time, not both. Similarly, a character may only have one magical defensive Aura spell – *Defense*, *Negation*, *Reflection*, or *Absorption* – on them at any one time. If a character has a latent defensive spell and an incompatible spell is cast on them, the spell that uses the most Power Points takes precedence. *Aura of Resistance* and *Purity* will not stack with themselves but can be combined with a physical and magical spell defense.

If a character is hit with a *Destroy Magic* spell then all the spells of the Auras School listed below are lost, excluding the *Armor* and *Stamina* spells. Further rules and description of the *Destroy Magic* spell is listed under the Thaumaturgy School.

The magical spell defenses may or may not work on other forms of magic than just the spells in these rules. For example, they are known to work against spell songs, but they do not work against curses. If you do not know whether some mystical attack on your character can be prevented by a magical defense, you can try invoking it, but even if the defense does not work, it is still used up.



### 1<sup>st</sup> Rank Auras

Spell Verbal: I Weave an Aura of...

**...Armor** **Duration:** Until Used Up  
1 Power Point

This spell gives the character an additional 3 Armor Points. These extra 3 Armor Points are the first Armor Points lost when the character is damaged.

**...Stamina** **Duration:** Until Used Up  
2 Power Points

This spell gives the character an additional 3 Body Points. These extra 3 Body Points are the first points lost when the character’s Body Points are damaged, but otherwise act as normal Body Points.

**...Defense** **Duration:** Latent  
3 Power Points

When invoked, this spell reduces the result of any damaging spell to one half. It has no effect against non-damage effect spells such as *Sleep* or *Drain Magic*.

A *Kill* spell is reduced to doing half the target’s full Body Points, rounded up, minimum of two. This spell will halve the effects of a *Life* spell cast upon a character hurt by the element of Life, if the undead is intelligent enough to invoke it. If the character drops to 0 or -1 Body Points they are Bleeding to Death, not at the Brink of Death.

### 2<sup>nd</sup> Rank Auras

Spell Verbal: I Weave a *Protective* Aura of...

**...Vigilance** **Duration:** Latent  
4 Power Points

When invoked, this spell gives protection against certain specific attacks: it prevents a Waylay with 3 or fewer points of damage from rendering the target unconscious and taking damage and it leaves the target of a Slay or an Assassinate skill with half their **current** Body Points. However, if direct body damage was done by the weapon, then any blade poisons on the weapon take effect.

*Vigilance* has no effect against any other form of attack, magical or non-magical, including a Waylay that does 4 or more points of damage.

**...Negation** **Duration:** Latent  
5 Power Points

When invoked, this spell completely cancels the effects of one spell cast upon the character. A *Negation* will stop spell like effects such as those from Nature Magic and Spell Songs normally.

**...Reflection** **Duration:** Latent  
6 Power Points

When invoked, *Reflection* turns a spell back upon its caster. If the caster also has a *Reflection* spell and chooses to invoke it, then the spell is reflected back upon the target again. If the original target still has some other appropriate form of defense against spells they may then invoke it.

A *Reflection* will stop magical spell like effects including those from Nature Magic and Spell Songs, but in these cases, while the spell is stopped, the spell is not redirected back at the caster.

For purposes of determining who the caster of a reflected spell is, the character that last used the reflection is considered the caster. For example, a character is hit with a *Paralysis* spell, they invoke a *Reflection* spell and the original caster is now paralyzed, and the original defending character can remove the *Paralysis* spell by touch since they are now considered the caster.

**3<sup>rd</sup> Rank Auras**

Spell Verbal: I Weave a *Protective and Warding* Aura of...

**...Fortitude** **Duration:** Latent, 5 Minutes  
7 Power Points

When invoked, this spell provides the character with a 4 Threshold, which negates all physical attacks on the target character that delivers 4 points of damage or less, for 5 minutes. If a blow does 5 or more points of damage, *Fortitude* will not block it.

If a character is under the affects of a *Fortitude* spell, then it takes a Waylay that does 5 or more points of damage to knock them unconscious. A *Fortitude* spell does protect a character from a Killing Blow, provided the damage done by the Killing Blow is four points or less and the spell's duration has not expired.

The Threshold provided by a *Fortitude* spell does not protect the character from any spells, only physical attacks are stopped and cannot be stacked with other Thresholds. As a rule, Thresholds do not add, only the most protective Threshold protects the character.

Once a *Fortitude* spell is invoked, it is no longer a latent spell and is considered an active spell. A character cannot invoke a *Fortitude* spell as a defense to an attack, they must already have the spell active to gain the benefits of the spell.

**...Absorption** **Duration:** Latent  
8 Power Points

When invoked, an *Absorption* spell negates the effect of a spell. Also, the actual, modified Power Points used to cast the negated spell are given to the character. This spell will not give a character any Power Points if they do not have the Power Point skill, nor will it give a character more Power Points than their normal Power Point maximum.

If a character uses an *Absorption* to stop an area of effect spell that does not strike them directly, the effect is stopped but the character gains no Power Points. For example, a character wishes to safely cross a *Wall of Flame* spell. They can call their *Absorption* to protect themselves from the damage, but gain no Power Points.

An *Absorption* will stop magical spell like effects including those from Nature Magic and Spell Songs, but in these cases, the effect is stopped but the character gains no Power Points from the spell even if the character is a Druid or Spell Singer.

**...Invulnerability** **Duration:** Latent  
8 Power Points

This spell protects against one physical attack. It cancels a Waylay, Slay, Assassinate, Stunning Blow, Critical Attack, or any other non-spell effect that does damage or harmful physical effect.

An *Invulnerability* spell can be used to stop a Killing Blow if the target is immobilized and still conscious, but the player *must* say the word "Invulnerability" audibly to give the attacker the chance to see the characteristic flash of light.

**...Purity** **Duration:** Latent  
8 Power Points

When invoked, this spell protects the character from one external alchemical attack. *Purity* will not stop any alchemy the character consumes.

*Paste of Binding*, acids, Fire Breath, Sunwater, *Paste of Stickiness*, and *Alchemical Lubricant* have an external effect but will not be stopped by this spell. These items are stopped by an *Invulnerability* spell.

**4<sup>th</sup> Rank Auras**

Spell Verbal: I Weave a *Protective and Warding* Aura of...

**...Resistance to Shield You** **Duration:** Latent  
12 Power Points

When invoked, this spell will stop any one physical or magical attack and follows all the standard rules for *Invulnerability* and *Negation* spells. A character can still only have one *Resistance* upon them at a time.

**5<sup>th</sup> Rank Auras**

Spell Verbal: I Weave a *Protective and Warding* Aura of...

**...Dragon Skin to Harden Your Hide** **Duration:** Latent, 10 Minutes  
16 Temporary Power Points,  
1 Permanent Power Point

When this latent spell is invoked, the character gains 25 Body Points that can be healed and Damage Resistance: Silver. Spells and other magical attacks still harm the character normally as does "Light" and "Dark" attacks.

This defense lasts for 10 minutes or until dispelled. The Body Points gained from this spell are the first to go, therefore when the spell ends, the character will not lose any additional Body Points if they are below their normal maximum.

**...Elder Resistance to Shield You from Harm** **Duration:** Latent  
24 Temporary Power Points,  
2 Permanent Power Points

This latent spell defense will stop any one attack or effect regardless of the nature of the attack. This includes warlock augmented spells, sorcery, martial skill, alchemy, faith, etc. Unlike some characters that have this affect as an innate ability, the character does not suffer a Torso Stun effect when they invoke this defense.



## Bonds School

### Special Rules for the Bond School

Any Bond School spell can be removed by its caster. The caster must touch the target player of the spell and say, "I Release You From (name of spell)". This also applies to the *Imprisonment* spell, as the act of touching the target player refers to the ability of the caster to make physical contact with the target, not the caster's character and the target character.

Almost all the Bond spells can be removed by a *Dispel Magic*; *Imprisonment* and *Impenetrable Portal* are the only two listed here that cannot. The *Pin*, *Bind*, *Paralysis*, and *Imprisonment* spells are not mutually exclusive and therefore, a character can be effected by all four at once.

Characters with an exceptional Strength Bonus are immune to the effects of certain Bonds School spells. **Only a Strength Bonus that is combinable counts at all towards determining if a character is immune to a Bonds School spell.** Skills, spells and alchemical items that grant a non-combinable Strength Bonus are never considered in the calculations, but skills and spells that grant even a temporary combinable Strength Bonus do count. The table below outlines the required Strength Bonus needed and what spell immunities are gained.

Spell Name	Strength Bonus
<i>Pin</i>	+2
<i>Bind</i>	+4
<i>Paralysis</i>	+6
<i>Imprisonment</i>	+8

Some characters are immune to the effects of Bond School spells. The commonly encountered ones are ethereal or incorporeal undead. Others to be sure exist, but the player must learn of these during game play.



### 1<sup>st</sup> Rank Bonds

Spell Verbal: I Create a Magical...

**...Attachment** **Duration:** 10 Minutes  
1 Power Point

This spell attaches an object that weighs no more than 10 pounds to another object. The caster must touch both objects during the casting of the spell. If more than 10 pounds of force is applied to the *Attachment*, it will break. For example, a bottle could have an *Attachment* to a staff, but an *Attachment* could not be used to fix a rope to a wall so a character could swing across a chasm.

You cannot cast multiple *Attachment* spells on an object.

This spell is not a combat spell. *Attachment* can be represented out-of-game by duct tape, but the caster is responsible for supplying the duct tape to attach the objects.

**...Pin** **Duration:** 30 Seconds  
2 Power Points

The spell attaches the right foot of the target character to the ground. The target can pivot on their right foot, but cannot lift it or move it.

A character can break a *Pin* with a +3 or more Strength Bonus and taking 5 seconds to complete.

There is a visible effect to this spell, and it is obvious to any one looking if the character is free or not.

### 2<sup>nd</sup> Rank Bonds

Spell Verbal: I Create a Magical *Seal That Will...*

**...Bind** **Duration:** 1 Minute  
5 Power Points

This spell attaches both of the target's feet to the ground and both of the target's arms to their sides. A *Bind* spell makes both spell casting and combat impossible. A bound character cannot be moved since their feet are attached to the ground, and if they are holding something in their hands, they cannot release it. Another player can remove an item from the target's hand(s), but doing so requires a +3 or more Strength Bonus and frees the target's arms. A bound character cannot be given a Killing Blow, provided that the character can still twist around.

A *Bind* spell can be partially broken with a +3 or more Strength Bonus. It takes 5 seconds to free either the character's arms or legs or 10 seconds to free both. If the character uses a *Giant Strength* spell to free themselves it would require two spells – the act of breaking either the arms or legs free counts as one action.

There is a visible effect to this spell, and it is obvious to any one looking if the character is free or not.

**...Lock** **Duration:** 1 Hour  
5 Power Points

This spell will seal a door, hold an object in place or attach an object to another object. A *Lock* spell can be represented out-of-game by duct tape, but the caster is responsible for supplying the duct tape to attach the objects.

This spell will not work on a character. An object cannot be attached to a character and a character cannot be attached to anything.

A *Lock* spell can be broken with +3 or more Strength Bonus such as by invoking a *Giant Strength* spell. If an object under the effects of a *Lock* spell is destroyed, then the spells ends.

**3<sup>rd</sup> Rank Bonds**

Spell Verbal: I Create a Magical *Seal that Will Cause...*

**...Paralysis** **Duration:** 5 Minutes  
7 Power Points

This spell completely paralyzes the target character; they cannot move or speak. The only acts a paralyzed character can perform are to move their eyes, blink, or invoke a latent spell. A character may be given a Killing Blow while they are paralyzed.

Paralyzed characters can be moved as they are not attached to the ground; in addition, their limbs can be moved by some external force such as another character. The target will still be unable to move from their new position. If the paralyzed character is reduced to 0 Body Points or lower, the player should still fall down.

There is a visible effect to this spell, and it is obvious to any one looking if the character is free or not.

**...Imprisonment** **Duration:** 5 Minutes  
9 Power Points

The target character is completely immobilized; they cannot move or speak. They are surrounded by a glowing, skin tight magical prison that protects them from all attacks, spells, or damage until the spell wears off. An *Imprisoned* character cannot be picked up or moved from the spot where the spell hit them. If the spell affects the character while they are not touching the ground – jumping in mid air, swimming, brachiating, being carried, in a tree, etc. – the character is immediately dropped to the ground under them when the spell hits.

The *Imprisonment* spell is not affected by the *Dispel Magic* or *Destroy Magic* spells. The effects of alchemical items cannot pass through an *Imprisonment*. If you cast an *Imprisonment* on yourself then you cannot remove it; you must wait until the 5 minutes elapse.

A target is still affected by the Hypnosis skill and other charm like gaze attacks. The Total Power skill will pierce through an *Imprisonment*, even if the original spell was cast with Total Power.

There is a visible effect to this spell, and it is obvious to any one looking if the character is free or not.

**...Free Action** **Duration:** Latent or Instant  
6 Power Points

This spell can be used in two different ways. First, it can be used to dispel any spell from the Bonds School when cast on the target character. It will only remove one active spell at a time and the character should call what spell they are dispelling when they cast this spell. If the character does not then the target player can choose what Bonds School spell they want dispelled if they are affected by multiple Bonds School spells.

The caster can choose to cast this spell as a latent spell defense. When used in this way, this spell defense will stop one spell from the Bonds School. This spell, when used in this manner, cannot be invoked to dispel an already active Bonds School spell.

**4<sup>th</sup> Rank Bonds**

Spell Verbal: I Create a Magical *Seal that Will Cause...*

**...a Wall of Paralysis** **Duration:** While  
9 Power Points Concentrating

This spell creates a 10 foot by 10 foot by 1 foot wall of magic; if anyone touches or passes through the *Wall of Paralysis* they are paralyzed and are affected as per the Paralysis spell.

This spell follows the normal wall spell rules found at the beginning of this chapter.

**5<sup>th</sup> Rank Bonds**

Spell Verbal: I Create a Magical *Seal that Will Cause...*

**...this Portal and Dwelling to be** **Duration:** 12 Hours  
**Impenetrable**  
20 Temporary Power Points  
1 Permanent Power Point

This spell will magically seal a building or room for 1 hour. No door, window or other exit can be opened and the entire building is indestructible for the duration. Only the caster may pass unhindered through the portals. Anyone else wishing to move through a portal requires a +7 Strength Bonus, non-combinable and the portal will remain open for as long as the character holds it open and can maintain the required Strength Bonus. If a portal is forced in this manner, the spell still stays in effect for the 1 hour duration.

While this spell is in effect, no attack can pass though any closed portal. If a portal is opened – either by the caster or by force – then any attack can pass through normally. The *Dispel Magic* and *Free Action* spells have no effect on this spell, however any sorcerous dispel will end this spell.

If there is no actual doorway – as with a lean-to, pavilion or archway for example – then the portal requires a +9 Strength Bonus to pass through and the character cannot bring any other character with them, nor can they get assistance from another character to pass through. No attacks can pass through no matter how strong the character is or how much damage attempts to pass the portal; only if the character actually forces their way through, can the spell be breached.



## Charms School

### *Special Rules for the Charm School*

Any Charm spell can be removed by its caster. The caster must touch the target of the spell and say, "I Release You From (name of spell)." Charm spells do *not* cease their effects if the caster falls unconscious or is in any stage of their Death Count.

The *Enslave* and *Dominate* spells are incompatible spells. If a character already has one of these spells cast on them and another spell is cast, the spell that uses the greater number of Power Points takes precedence. If a character has one of these spells cast on them and the same spell is cast on them again, the more recently cast spell takes precedence. Also, you cannot command someone to do something they cannot do; for example, you cannot order a character to resist a *Speak the Truth* spell if they could not normally resist it; you *can* cast a *Resist Suggestion* and order the character to use it. Similarly, you cannot order a person to use a Slay skill on someone if they do not have the skill or have already used it during that Tag Cycle.

Remember, a character can never be forced through the use of these spells to lose permanent pool points, Body Points or skills.



### 1<sup>st</sup> Rank Charms

Spell Verbal: I Command You to...

**...Fumble <right/left hand>**      **Duration:** Instant  
1 Power Point

This spell causes the target character to drop everything in-game they are holding in a specified hand. The target must let go completely, allowing all the items in that hand to fall to the ground. The caster of the *Fumble* must specify which hand is affected with an out-of-game comment when the spell packet hits the target; e.g., "I Command You to Fumble... Right Hand".

If an item is attached to a character by some means other than a physical grip, then that item is not dropped; for example, a sword that is glued to a character's hand with a *Paste of Stickiness* would stay in the character's hand even though the character releases their grip. The Disarm skill cannot be used as a Retain against the *Fumble* spell.

If you are the target of a *Fumble* spell, then after you have let go of everything you are holding in one hand, you may then bend down and pick it up. You may *not* bend down, let your hand relax, then immediately grab an item and straighten up. You must let everything in your hand drop, and *then* bend down to pick it up.

**...Speak the Truth**      **Duration:** One Question or  
2 Power Points      5 Minutes, Whichever  
Comes First

This spell causes the targeted character's answer to the next question the caster – and only the caster – asks to be direct and truthful; the target can choose not to speak, but if they do speak it must be the truthful answer to the caster's question. If the caster does not ask a question before 5 minutes have elapsed, the spell expires. Only the caster of the spell can ask the question; the target can still respond to questions from others but the target does not have to speak the truth.

*Speak the Truth* only lasts for the first sentence of an answer to the question. If the question is phrased in such a way that a simple answer can be given, then the target must state the simple, true answer. If the question is phrased such that only a long answer can be given, then the caster should only trust the first sentence. For example, "Did you kill the Duke?" has a simple answer; "What was your plan to kill the Duke?" may take more than a single sentence to answer.

### 2<sup>nd</sup> Rank Charms

Spell Verbal: I Command You to *Obey and*...

**...Be Dazzled**      **Duration:** 5 Seconds  
4 Power Points

The target character of this spell is affected by a Torso Stun for 5 seconds. The target should count slowly out of game, "One dazzle, two dazzle..." slowly up to five.

**...Resist Suggestion**      **Duration:** Latent  
5 Power Points

This spell cancels the effect of one spell from the Charms School. It is ineffective against all other forms of mental control, Hypnosis, *Dust of Sleep*, Fear Affects, Vampire Charm, etc. for example.

Unlike most latent spells, *Resist Suggestion* does **not** have to be announced when it is invoked; there is no characteristic flash of light when this defense is used. A player with a *Resist Suggestion* spell knows which Charm spell has been cast on them and can decide whether to invoke it based on that information. You must invoke your *Resist Suggestion* immediately after being hit with the charm spell. You cannot be affected by a *Speak the Truth* spell then invoke



the *Resist Suggestion* spell after hearing the question being asked and decide not to answer truthfully.

If a character invokes *Resist Suggestion* in a manner that is not immediately obvious, they should consult with a Marshal to confirm that the spell was used. For example, if a character uses *Resist Suggestion* against an *Enslave* spell but is still pretending to be affected, or if a character resists a *Speak the Truth* spell during an interrogation, a Marshal should be informed. It is therefore important that the caster of a *Resist Suggestion* give the player the Power Point tags used to cast the spell so that the player has proof that they could invoke it.

**...Be Silent and Mute** **Duration:** 1 Minute  
6 Power Points

The target character of this spell cannot speak. This means the target cannot use any spells, skills or abilities that require an in-game verbal. Remember, the use of latent spells, magic items, and weapon damage does not require the player to speak in-game, and is not affected by this spell. This spell lasts until a *Dispel Magic* or a *Heal Limb* spell is cast.

The target of this spell is still under their own free will and therefore not cut off from their faith based skills.

### 3<sup>rd</sup> Rank Charms

Spell Verbal: I Command You to *Obey and Charm You to...*

**...Fall Asleep** **Duration:** 5 Minutes  
6 Power Points

This spell causes the target character to fall asleep. The character will wake up before the 5 minute duration has elapsed if they take a point of damage. The character may be given a Killing Blow while asleep.

**...Be Enslaved** **Duration:** 5 Minutes  
8 Power Points

This spell causes the target character to obey all the caster's commands. A character affected by an *Enslaved* spell will commit suicide or attack their friends at the caster's command. However, the enslaved character will act without emotions or self determination; you should roleplay your enslavement so that it is obvious to everyone that the spell has been cast on your character.

An enslaved character cannot obey commands that require independent thought or initiative, such as "Solve this riddle for me," or "Figure out a plan to kill the princess." The character must do exactly as they are instructed; they cannot initiate conversation, take independent action, or act in any way in their best interests. If asked a question they will answer truthfully for they have no desire to protect themselves. If ordered to attack another character they will do so to the best of their abilities. They can be given contingent commands such as "Kill anyone entering the room," "Go to the inn and kill the Duke if he is there or wait there and kill him when he enters," or "Go find the Baron of the Dale and give him this missive."

The enslaved character will never attack the caster of this spell while they are still under the spell's effects.

After the spell wears off, the character will remember everything that occurred while they were enslaved, including the identity of the caster of the spell.

### 4<sup>th</sup> Rank Charms

Spell Verbal: I Command You to *Obey and Charm You to...*

**...Be Dominated and Controlled** **Duration:** 1 Hour  
12 Power Points

This spell causes the target character to obey all the caster's commands. A character affected by a *Dominate* spell will otherwise behave normally, except that a dominated character will not harm the caster or cause the caster to be harmed unless the caster commands them to do so. A dominated character is not aware they are under the affects of this spell; if asked with a *Speak the Truth* spell they will not realize they have been dominated and would correctly answer "No".

A dominated character can be commanded to perform tasks that require some thought – "Solve this puzzle" for example – but they cannot be ordered to do something they cannot normally do. You cannot order someone to use a Slay or Assassinate skill if they do not normally have the ability to do so or they have used that skill for the current Tag Cycle.

The caster can order a character to do something they would normally not do. The caster could order someone to kill their spouse or best friend for example. "Using all your skills, abilities and items to the best of your ability go and kill the Baron of the Dale when I leave this building," is an acceptable command. The caster can give any number of commands to the dominated character.

The caster can prompt the dominated character with false information or facts. The caster could, for example, tell the character "The undead outside are not dangerous or evil and will help you if you ask them." The character would not run or start a fight with the undead when they met them, but would defend themselves if attacked. The dominated character can be told that their best friend is their most hated enemy. No amount of convincing on someone else's part will change the character's mind. However, the character will not make up reasons why their best friend is their most hated enemy, and would remember being best friends. The caster can prompt the dominated character with complicated memories to make the false facts more believable to others but the dominated character needs no convincing they simply believe what the caster tells them as the absolute fact.

Similarly the caster can tell the dominated character to forget facts and events – even to forget skills. However, once the spell ends all the lost memories will return normally.

After the *Dominate* spell wears off, the target will remember who cast the spell on them and what they did while dominated. All false facts and information will be remembered as false and the character's own values and beliefs will be intact.

### 5<sup>th</sup> Rank Charms

Spell Verbal: I Command You to *Obey and Charm You to...*

**...Be My Soul Slave to Obey My** **Duration:** Event  
**Every Command as I Enslave**  
**your Mind and Body and**  
**Dominate your Soul Forever**

30 Temporary Power Points  
2 Permanent Power Point

This spell works like a *Domination* spell with the following differences. First, the spell's duration is until the end of the current Event and will persist even after the character resurrects. This spell is not detectable by any low magic spell.

The *Sever Magic* and *Dispel Magic* spells work normally.

## Death School

### *Special Rules for the Death School*

If a Death spell does damage, it does so directly to a character's Body Points. Death spells do not affect armor. Death spells that cause damage will heal undead; the undead adds to its Body Points the amount of damage that would normally be done by the spell, up to the character's starting total. The *Kill* spell has a special effect on undead and is described below, but note that lesser undead dissolve into dust when they are slain and cannot be restored by these spells. The rest of the non-damaging spells will have no effect on undead.

### 1<sup>st</sup> Rank Death

Spell Verbal: I Call Upon Darkness to...

**...Feign Death** **Duration:** 10 Minutes  
1 Power Point

This spell will make the target character look pale; their skin will be cold to the touch and their pulse and breath will be unperceivable and to most observations, they will appear to be dead. A *Detect Life* spell, *Assess Your Ailment* spell or First Aid will not reveal that the character is alive. *Feign Death* will allow a character to impersonate an undead; the illusion of death is destroyed if the target character takes any offensive actions or engages in combat, but not if they are attacked.

**...Cause Harm** **Duration:** Instant  
2 Power Points

This spell does 6 points of magical direct body damage.

### 2<sup>nd</sup> Rank Death

Spell Verbal: I Call Upon Darkness *and Terror* to...

**...Weaken** **Duration:** 1 Minute  
4 Power Points

This spell causes the target character to deal no more than 1 point of damage with all martial attacks regardless of their Damage Bonus or Strength Bonus. This spell does not affect special weapon attacks like the Slay skill, Assassinate skill, Stun skill, etc. For skills that modify damage, the base weapon damage is always 1. For example, if a weakened character uses a Critical Attack skill, they will deal 2 points of damage. Similarly, a weakened character will only Waylay dealing 1 point of damage.

A character will lose all Strength Bonuses for the duration of this spell.

**...Maim** **Duration:** Instant  
4 Power Points

This spell does 12 points of magical direct body damage.

**...Take Your Sight** **Duration:** 1 Minute  
6 Power Points

This spell causes the target character to be unable to see for 1 minute or until they are healed. A *Heal Limb* spell or effect can be used to restore their sight. While blinded a character cannot make any melee attacks unless they have the Blind Fighting skill. They can close their eyes and throw a spell "blind". They can use their weapons to attempt to block attacks directed at them, so long as their eyes are closed and do not attempt to swing their weapon around wildly. They are able to use any passive defensive skills they have, such as Martial Parry, Critical Parry, *Negation* spell, etc. Even if a character has the Blind Fighting skill, they cannot use the True Aim or Perfect Aim skills.

When you role-play the effects of a *Take Your Sight* spell, you can close your eyes. However, take care if you are on rough terrain or in a room with sharp furniture. It is better to keep your eyes open and be safe than it is to roleplay your character's blindness convincingly.

This spell damages the eyes of the target character so, like other damaging spells, the caster cannot remove their own spell nor can any other character dispel these effects, the target character must be healed.

**...Cause Agony** **Duration:** 5 Seconds  
5 Power Points

This spell causes the target character intense pain for 5 seconds during which time the character must fall to the ground and can take no other actions except to invoke latent spell defenses. This spell can be cured with a *Heal Body* or *Dispel Magic* spell.

### 3<sup>rd</sup> Rank Death

Spell Verbal: I Call Upon Darkness *and Terror* to...

**...Drain Life** **Duration:** Instant  
6 Power Points

This spell does 12 points of magical direct body damage and heals the caster for the amount of damage done by the spell. If the target had 12 Body Points or more, then 12 Body Points are transferred to the caster; if the target has less than 12 Body Points, then only the amount the target has are transferred. The caster cannot be healed to more than their normal Body Point limit.

This spell has no effect when cast on an undead character. If an undead character casts this spell, the target takes 12 Body Points of damage, but the undead is not healed.

The exchange of Body Point tags is mandatory when this spell is used. If this spell is used on an NPC who does not have any Body Point tags, then the NPC must take the Power Point tags used to cast the spell, write down the number of Body Points transferred, and sign their out-of-game name.

**...Cripple** **Duration:** Instant  
6 Power Points

This spell does 18 points of magical direct body damage.

**...Enfeeble Your Mind** **Duration:** 5 Minutes  
7 Power Points

This spell causes the target character to lose all intelligence; they cannot use any skills, spells, invoke latent spells, invoke magic items or take any defensive actions. An *Enfeebled* character effectively becomes the village idiot.

This effect lasts for 5 minutes or until healed with a heal mind effect. The *Dispel Magic* spell has no effect on this spell.

**...Incapacitate Your Body** **Duration:** Instant  
8 Power Points

This spell does 24 points of magical direct body damage.

# Lost Magic

**4<sup>th</sup> Rank Death**

Spell Verbal: I Call Upon Darkness *and Terror* to...

**...Kill You and Wreak Havoc Upon Your Soul** Duration: Instant

12 Power Points

This spell causes the target character to go to -1 Body Points and to the Brink of Death. The character can be restored to life with the appropriate spells or skills.

This spell is the equivalent of a *Heal Life* spell for an undead.

**...Cast a Wall of Enfeeblement** Duration: While Concentrating

9 Power Points

This spell creates a 10 foot by 10 foot by 1 foot wall of magic; if anyone touches or passes through the *Wall of Enfeeblement* they are affected by an *Enfeeblement* spell.

This spell follows the normal wall spell rules found at the beginning of this chapter.

**...Create a Spectral Weapon** Duration: Latent, 5 Minutes

10 Power Points

This latent spell is cast upon a weapon, and when invoked, will cause the weapon to swing for direct Body Point damage for 5 minutes. This spell will add no additional damage. The player should call "Body" after the amount of damage they are doing.

**5<sup>th</sup> Rank Death**

Spell Verbal: I Call Upon Darkness *and Terror* to...

**...Kill Any Who Dare to Cross this Wall of Ash Before Me** Duration: While Concentrating

18 Temporary Power Points

1 Permanent Power Point

This spell creates a 10 foot by 10 foot by 1 foot wall of magic; if anyone touches or passes through the *Wall of Ash* they are affected by a *Kill* spell.

This spell follows the normal wall spell rules found at the beginning of this chapter.

**...Kill You and Hold Your Soul in Agonizing Torment Until You Die** Duration: Instant, *Special*

20 Temporary Power Points

1 Permanent Power Points

This spell affects the target character just like a *Kill* spell, except their Death Count is reduced by half and the character must roleplay being in agonizing torment for the duration of this spell. During this time, the character can not move themselves from where they fell and can take no other actions. They cannot cast spells, attack, defend, call any latent spell, invoke any magic items, or even speak coherent thoughts.

A *Sever Magic* spell cast at the caster or a *Dispel Magic* spell cast at the target character will not end the torment, however the character can be healed normally.

**Demonology School*****Special Rules for the Demonology School***

Cost: 3/3/4/4

Demonology is a wholly evil school of magic. It allows its practitioners to summon and control demons and offers a limited number of damaging and utility spells.

When your character learns Demonology, you must carry any costuming and claws for the demons you wish to create and their approved demon Character Card.

None of the summoning spells will work on Followers of the Light. Additionally, these spells cannot be cast upon ground that has been sanctified to the High Lord or the Mother. If the character affected by a summon demon spell is on sanctified ground to either god when the spell ends, it will fail. Additionally, a *Dispel Magic* spell will not stop the demon from being summoned, only healing the affected character will save them from their fate.

If a caster summons a demon with a Demonology spell, they have control over it. For Lesser Demons and Demons which have a character level associated with them, the player should use their character's card for the demon. The summoned demon does not have any of the faith skills the character had except Servants of Darkness skills which the demon character can use freely without a focus.

It is important to note that while the demon summoned used the character's card, it is not the character. Therefore, they should reset all their Tag Skills while playing the NPC and whatever skills are used do not affect the player's character. The target character's in-game items can be used by the demon at the caster's desire. The demon summoned occupies the same place as the character once did, and the demon appears wearing the character's clothing and equipment.

If *Sever Magic* is used on the caster to cancel their control over their demons, they will continue to follow and carry out their last commands. If they did not have any specific commands, then the demon reverts to their normal behavior. If another caster uses a *Command Demon* spell to issue a command, the original creator may override that command if they are present; the original caster just has to speak for the demon to obey.

If your character is used to summon a demon, then a death must be recorded on your Character Card when you are resurrected, and they will suffer the normal consequences of the Death System. After the resurrection, your character will remember being tormented in Hell but no specific details.

All of the demons created in this school, unless noted in the spell description, will last for 1 hour then return to Hell. They do not take anything with them, leaving whatever items they are carrying on the ground where they were destroyed or the spell ended. However, if the character used to summon the demon is on their last death, the demon summoned will remain until killed.

The summon demon spells use the character's soul as the sacrifice to bring the demon to this world. The character's soul goes to Hell and is trapped there – and as a consequence cannot resurrect – until the demon here is destroyed.

**Demonology spells cannot be absorbed to gain Power Points. An *Absorption* spell will stop the effect, but gives the character no Power Points.**



### The Demonic Pact and Aspect

In order to learn Demonology, the character must be taught by a demon capable of teaching this magic. This demon will extract a price for this knowledge, nothing less than their immortal soul. This demonic pact marks the characters soul forever and when the character dies they are guaranteed to spend the rest of eternity in Hell.

Should this contract with Hell ever be broken, the character is unable to cast Demonology spells until a new pact is made.

Making the initial pact can be a tricky matter. The character must find a teacher in-game. Demons guard their knowledge most jealously and do not normally allow tomes to be made.

At the time the pact is signed, the character must choose which aspect of Hell they will follow: fire, ice or undeath. This will directly affect how the character's spells work. For example, should the character choose fire, then the type of demon they summon is fire and the spells will deal fire damage. Their aspect never changes unless their contract is passed to another and they change the aspect.

The three <Aspect> verbals would be:

- From the *Unending and Fiery* Pits of Hell I...
- From the *Unending and Icy* Pits of Hell I...
- From the *Unending and Undying* Pits of Hell I...



### 1<sup>st</sup> Rank Demonology

Spell Verbal: From the Pits of Hell I...

**...Detect Demon.** **Duration:** Instant  
0/1 Power Point

This spell can be cast upon a character or item and will reveal if the character is a Demon or possessed by a Demon. If cast upon an item, it will reveal if that item contains a trapped Demon.

**...Summon an Imp.** **Duration:** 1 Hour, *Special*  
3 Power Point

This spell will summon an Imp of the appropriate type depending on the Demonologists Aspect. The character must be in their Death Count for the spell to affect them; if cast upon an undead character or a character who is not at least Bleeding to Death, the spell has no effect and the Power Points are wasted. At the end of the character's Death Count, their soul is sacrificed to Hell and an Imp will emerge from the dead character's body. The character's soul spends a short time in Hell where it is tormented by the denizens of Hell. If the character is healed before the end of their Death Count, the spell ends and the summoning fails. Dispel magic will not stop the spell.

When the demon is destroyed, banished, or 1 hour passes, then the demon returns to Hell, leaving whatever worldly possessions it had behind. The player may now go to the Healer's Guild and resurrect. There is no special consequence of their time spent in Hell other than not being able to play, while playing the demon.

### 2<sup>nd</sup> Rank Demonology

Spell Verbal: From the *Unending* Pits of Hell I...

**...Scourge Your Hands.** **Duration:** Instant  
5 Power Point

This spell does 8 points of damage to the character with the effect listed below depending on the Demonologists Aspect. Additionally, the character must drop whatever is in their hands. They may pick up the item immediately after they drop the items. This is not a charm effect.

Aspect	Damage
Fire	8 Magic Fire
Ice	8 Magic Ice
Undeath	8 Magic Body*

\* Note this does not heal undead.

**...Summon a Demonling.** **Duration:** 1 Hour, *Special*  
5 Power Point

This spell will summon a Demonling of the appropriate type depending on the Demonologists Aspect. The character must be in their Death Count for the spell to affect them; if cast upon an undead character or a character who is not at least Bleeding to Death, the spell has no effect and the Power Points are wasted. At the end of the character's Death Count, their soul is sacrificed to Hell and a Demonling will emerge from the dead character's body. The character's soul spends a short time in Hell where it is tormented by the denizens of Hell. If the character is healed before the end of their Death Count, the spell ends and the summoning fails. Dispel magic will not stop the spell.

When the demon is destroyed, banished, or 1 hour passes, then the demon returns to Hell, leaving whatever worldly possessions it had behind. The player may now go to the Healer's Guild and resurrect. There is no special consequence of their time spent in Hell other than not being able to play, while playing the demon.

**...Command Lesser Demons.** **Duration:** 1 Hour  
6 Power Point

This spell will allow the caster to control all Imps, Demonlings, Hellhounds, and Minor Demons in the sound of their voice. This spell will not override a *Dominate Demon* spell, a Follower of Lights turn ability, or a Servant of Darkness command ability.

**...Shield my Body from Possession.** **Duration:** Latent, *Special*  
6 Power Point

This latent spell will protect the character from being possessed. Once invoked the character cannot be possessed from that character for the remainder of the Tag Cycle.

### 3<sup>rd</sup> Rank Demonology

Spell Verbal: From the *Unending* <*Aspect*> Pits of Hell I...

**...Summon a Hell Hound.** **Duration:** 1 Hour, *Special*  
7 Power Point

This spell will summon a Hell Hound of the appropriate type depending on the Demonologists Aspect. The character must be in their Death Count for the spell to affect them; if cast upon an undead character or a character who is not at least Bleeding to Death, the spell has no effect and the Power Points are wasted. At the end of the character's Death Count, their soul is sacrificed to Hell and a Hell Hound will emerge from the dead character's body. The character's soul spends a short time in Hell where it is tormented by the denizens of Hell. If the character is healed before the end of their Death Count, the spell ends and the summoning fails. Dispel magic will not stop the spell.

When the demon is destroyed, banished, or 1 hour passes, then the demon returns to Hell, leaving whatever worldly possessions it had behind. The player may now go to the Healer's Guild and resurrect. There is no special consequence of their time spent in Hell other than not being able to play, while playing the demon.

Hell Hounds cannot use the items of the character used to summon it.

**...Cast a Circle of Binding.** **Duration:** End of Tag Cycle  
7 Power Point

This spell is cast using the same rules as a wall spell, however it must always be a closed 10' long piece of garland in a roughly circular shape. The caster can make the circle with up to a 20' piece of garland if they wish.

Any demon or demon possessed character or item cannot pass out of the circle. They cannot attack, cast spells or use abilities or skills outside the circle. They can affect anything in the circle they wish. Additionally, demons may pass into the circle but not out again. Demons trapped inside the circle cannot affect the circle, but a demon on the outside can.

The circle will dissipate at the end of the Tag Cycle or if a *Dispel Magic* is cast upon the circle.

**...Summon a Minor Demon.** **Duration:** 1 Hour, *Special*  
8 Power Point

This spell will summon a Lesser Demon of the appropriate type depending on the Demonologists Aspect. The character must be in their Death Count for the spell to affect them; if cast upon an undead character or a character who is not at least Bleeding to Death, the spell has no effect and the Power Points are wasted. At the end of the character's Death Count, their soul is sacrificed to Hell and a Lesser Demon will emerge from the dead character's body. The character's soul spends a short time in Hell where it is tormented by the denizens of Hell. If the character is healed before the end of their Death

Count, the spell ends and the summoning fails. Dispel magic will not stop the spell.

When the demon is destroyed, banished, or 1 hour passes, then the demon returns to Hell, leaving whatever worldly possessions it had behind. The player may now go to the Healer's Guild and resurrect. There is no special consequence of their time spent in Hell other than not being able to play, while playing the demon.

**...Burn Your Soul.** **Duration:**  
9 Power Point

This spell does 24 points of damage to the character with the effect listed below depending on the Demonologists Aspect.. Additionally, the character is affected by a 5 second Torso Stun.

Aspect	Damage
Fire	24 Magic Fire
Ice	24 Magic Ice
Undeath	24 Magic Body*

\* Note this does not heal undead.

### 4<sup>th</sup> Rank Demonology

Spell Verbal: From the *Unending* <*Aspect*> Pits of Hell I...

**...Hasten Your Demise.** **Duration:** Instant, *Special*  
10 Power Point

This spell, when cast on a character in their Death Count, cuts their Death Count and current count in half. This can only be cast on a character once per Death Count; it does not stack with itself.

*For example, Zagon and his friends are fighting a Demonologist and his minions. Zagon is reduced to -1 Body Points and falls. The player begins his Death Count and hopes his friends come by to save him. The Demonologist casts a Hasten Your Demise on Zagon. His current Death Count is Bleeding to Death at 40 seconds. After the spell is cast, Zagon's current Death Count is Bleeding to Death at 20 seconds and only has 10 seconds before he goes to the Brink of Death. After that he will only have 2 and a half minutes at the Brink of Death to get a life effect.*

The spell ends when the character dies or receives appropriate healing. *Dispel Magic* has no effect on this spell.

**...Dominate this Demon.** **Duration:** 1 Hour  
12 Power Point

When a demon is affected by this spell, it will obey all the commands given by the caster. This spell will affect all demons, including greater demons, but not Hierarchs. However, intelligent demons cannot be ordered to kill themselves; they will also remember who cast the spell on them and may seek vengeance once the spell has worn off. Unlike the Charm School spells, the affected, intelligent demonic character may attack the caster if they wish unless ordered not to.

This spell allows the caster to control any demon type regardless of their aspect.

**...Summon Dark Energies to Power Me.** **Duration:** *Special*  
15 Power Point

This spell grants the caster a demonic energy pool of the type listed below. The caster can throw the pool at any rate up to the total of

their current points or empower their weapons or claws to swing for +1 for each pool point put into the attack. This requires no verbal to use.

The pool will fade away after 1 hour if not used.

Aspect	Pool
Fire	40 Magic Fire Pool
Ice	40 Magic Ice Pool
Undeath	40 Magic Body Necromantic Pool*

\* Note this does heal undead.

This spell is not stackable with itself.

**...Summon a Demon to Obey Me.** Duration: 1 Hour, *Special*  
20 Power Point

This spell will summon a Superior Demon of the appropriate type depending on the Demonologists Aspect. The character must be in their Death Count for the spell to affect them; if cast upon an undead character or a character who is not at least Bleeding to Death, the spell has no effect and the Power Points are wasted. At the end of the character's Death Count, their soul is sacrificed to Hell and a Demon will emerge from the dead character's body. The character's soul spends a short time in Hell where it is tormented by the denizens of Hell. If the character is healed before the end of their Death Count, the spell ends and the summoning fails. Dispel magic will not stop the spell.

When the demon is destroyed, banished, or 1 hour passes, then the demon returns to Hell, leaving whatever worldly possessions it had behind. The player may now go to the Healer's Guild and resurrect. There is no special consequence of their time spent in Hell other than not being able to play, while playing the demon.

**...Summon Total Demonic Power to Infuse me with Magic.** Duration: End of Tag Cycle  
20 Power Point

This spell draws upon Hell's infernal power to grant the caster extra Power Points which can only be used to cast other Demonology spells. Every time this spell is cast, the caster gains 30 Power Points. The character can only use unadjusted Power Points to cast this spell, they cannot use Demonic Power Points to cast this spell.

The character should write the spells name on the back of the Power Point Tags used to cast the spell indicating their increased value.

## 5<sup>th</sup> Rank Demonology

Spell Verbal: From the *Unending* <Aspect> Pits of Hell I..

**...Banish This Demon Back to the Abyss from Whence it came for a Moon and a Day.** Duration: 1 Event

30 Temporary Power Points  
2 Permanent Power Point

This spell will banish any demon back to Hell including Heirarchs for the rest of the current Event and the next Event.

## Enchantments School

### *Special Rules for the Enchantments School*

There are no special rules for the Enchantments School.

### 1<sup>st</sup> Rank Enchantments

Spell Verbal: With Pure Magic I Cast a...

**...Shock** Duration: Instant  
1 Power Point

This spell does 4 points of magical damage due to lightning.

**...Giant Strength** Duration: Latent  
2 Power Points

When invoked, this spell grants the character a temporary +3 Strength Bonus, Non-Combinable allowing the character to add +3 to the weapon damage of their next attack, or to perform one act of giant strength for no longer than 15 seconds. If the character normally calls "Two Damage" when they hit, if they invoke a *Giant Strength* they would call "Five Damage". If the character fails to hit, they do not use up the *Giant Strength* spell.

This spell can never be used to increase the distance a character jumps.

### 2<sup>nd</sup> Rank Enchantments

Spell Verbal: With Pure Magic I Cast a...

**...Lightning Shield** Duration: Latent  
3 Power Points

When invoked, this spell will cancel the effects of one Enchantments School spell. The *Lightning Shield* spell will also negate one blow from a weapon that does normal or magical lightning or electrical damage, but will not stop special damaging martial attacks such as the Slay, Critical Strike, Stun, Assassinate, etc. skills. A *Lightning Shield* will protect against extreme non-magical lightning or electricity for 5 seconds.

**...Lightning Bolt** Duration: Instant  
4 Power Points

This spell does 16 points of magical damage due to lightning.

**...Magic Weapon** Duration: Latent  
4 Power Points

This spell can only be cast on a weapon. If you hold the weapon, you can invoke this spell, which causes the next weapon attack done by the weapon to be magical. The *Magic Weapon* spell does not add any damage to the blow. The attacker must add, "Magic", to the damage done by the weapon when invoking the spell; for example, "Two Magic". The *Magic Weapon* spell only lasts for one blow, but if an attacker fails to hit their target the spell is not used up. *Magic Weapon* can be combined with any other combat skill such as Waylay, Slay, Assassinate, Critical Attack, etc.

This spell can be invoked and used with the Dissection skill to harvest a component from another character. This spell will last for 1 minute, but should the dissection be interrupted, the spell ends and must be recast.

This spell can never be invoked as a defense to the *Shatter* or *Blast* spells, nor does it give the weapon any properties of a magic weapon except what is listed here.



**...Mighty Shatter <item>****Duration:** Instant

4 Power Points

This spell will destroy a non-magical object of One-Handed Edge size or smaller. The name of the item that the caster wishes to shatter is an out-of-game comment that the caster says when the spell packet hits a target, for example, “With Pure Magic I Cast a Mighty Shatter... sword.” If the character is carrying more than one weapon in their hands, the caster can specify which weapon or hand is affected; if the caster does not specify then the target can choose which hand is affected.

The object that is being shattered must be visible to the caster; the caster cannot shatter a spell book completely contained within a pouch even if the caster knows that a spell book is there. This spell will not affect part of an object – a piece of the object that will damage or destroy it by removing the part out-of-game. For example, you could not destroy: the hinge on a box, the branch of a tree, a lock built into a box, the leg of a small stool, the doorknob of a door, etc. You can destroy: a box, a branch on the ground, a Master Lock on a box, a small stool, etc.

Clothing worn by a player can never be shattered with this spell; this includes: shirts, pants, belts, pouches, hats, shoes, etc. You can destroy jewelry or other things attached to the clothing such as: rings, bangles, necklaces, pins, etc. Armor cannot be shattered by means of this spell. No shield, regardless of size, can be shattered.

If any weapon or item card was associated with the shattered item, the card should be torn in two. An item that has been shattered is broken into too many pieces to be collected.

**3<sup>rd</sup> Rank Enchantments**Spell Verbal: With Pure Magic I Cast an *Unyielding*...**...Wall of Force****Duration:** While

6 Power Points

Concentrating

This spell creates a 10 foot by 10 foot impenetrable wall. Nothing can pass through the wall, including spells and alchemical items; only clean non-poisoned air is allowed to pass. The Total Power skill will pierce through a *Wall of Force*, even if the original spell was cast with Total Power.

This spell follows the normal wall spell rules found at the beginning of this chapter.

**...Powerful Blast <item>****Duration:** Instant

6 Power Points

This spell will destroy a non-magical object of door size or smaller. The name of the item that the caster wishes to blast is an out-of-game comment that the caster says when the spell packet hits a target, for example, “With Pure Magic I Cast a Powerful Blast... door” or “With Pure Magic I Cast a Powerful Blast... Polearm.”

In all other respects, this spell obeys the same rules as the *Shatter <item>* spell except any shield can be affected by the *Blast* spell.

**...Electrocution****Duration:** Instant

6 Power Points

This spell does 24 points of magical damage due to lightning.

**Lost Magic****...Magic Sanctuary****Duration:** While

9 Power Points

Concentrating

This spell creates a skin-tight impenetrable barrier around the caster. The *Magic Sanctuary* spell protects the caster from all attacks, spells, and alchemical items; and provides the caster with clean air. Neither the *Dispel Magic* nor *Destroy Magic* spells can negate this spell. A *Magic Sanctuary* is a complete protection against the outside world; other characters may not pick up or move the caster, nor may they apply weight to the caster's arm to make the caster lower it before the caster chooses.

The caster is still affected by certain attacks. Hypnosis is one such attack. The character can be ordered to drop the *Magic Sanctuary*. The Total Power skill will pierce through a *Magic Sanctuary*, even if the original spell was cast with Total Power.

While a caster maintains a *Magic Sanctuary*, they may not pick up objects, drop objects, strike with a weapon, drink potions, or cast any spells, even on themselves. The caster can pass through anything that is not actively resisting such as light branches. If someone blocks the caster's path, the caster cannot move them and cannot be moved by them either. This spell will allow the character to walk through water, blizzards, sandstorms, or even lava unharmed. A caster can move through a free swinging door, but cannot turn a knob or open a latch. The caster cannot affect the outside world with any skills, spells, abilities, magic items, etc while they are maintaining this spell. The caster could not, for example, use gaseous alchemical items or invoke area affect magic items while in a *Magic Sanctuary* spell.

A *Magic Sanctuary* only protects the caster; if someone is touching the caster when the spell is cast, they are **not** protected as well.

While they are maintaining a *Magic Sanctuary*, the player must hold an arm out to their side parallel to the ground, elbow bent up at a right angle, and palm forward. Also, the caster must walk slowly, no faster than one step per second. If the caster drops their arm or moves faster than one step per second, the sanctuary dissipates.

Like all spells, a *Magic Sanctuary* does not last beyond the end of an Event.

**4<sup>th</sup> Rank Enchantments**

Spell Verbal: With Pure Magic I Cast an *Unyielding*...

**...Powerful and Masterful Strength** **Duration:** Latent, 5 Minutes

10 Power Points

This latent spell grants the character a +2 Strength Bonus, Non-Combinable for 5 minutes after the character invokes the spell. This Strength Bonus can be stacked with other Strength Bonuses, even a *Giant Strength* spell.

**...Circle of Force to Protect Me** **Duration:** While Concentrating

12 Power Points

This spell creates a 10 foot high, 10 foot radius impenetrable wall. Nothing harmful can pass through the wall, including spells and alchemical items; only clean non-poisoned air is allowed to pass. The Total Power skill will pierce through a *Circle of Force*, even if the original spell was cast with Total Power. The *Circle of Force* is centered on the caster and the caster cannot move while maintaining this spell.

This spell follows the normal rules for wall spells found at the beginning of this chapter.

**5<sup>th</sup> Rank Enchantments**

Spell Verbal: With Pure Magic I Cast an *Unyielding*...

**...Haven About Me to Protect Me on My Way** **Duration:** While Concentrating

21 Temporary Power Points

1 Permanent Power Point

This spell creates a 10 foot high, 10 foot radius impenetrable closed cylinder centered on the caster. Nothing harmful can pass through the wall, including spells and alchemical items; this spell will provide clean air enough for everyone inside. The Total Power skill will pierce through a *Haven*, even if the original spell was cast with Total Power.

While they are maintaining a *Haven*, the player must hold both arms out to their sides parallel to the ground, elbows bent up at a right angle, and palms forward. If the caster drops their arm, the spell dissipates. Also, the caster must walk slowly, no faster than one step per second. Unlike Magic Sanctuary, this spell will push characters out of the way and will conform to allow the caster to move through smaller diameter portals. When cast, the caster can specify who is in the initial 10 foot radius; all other characters are pushed out to 10 feet.

This spell is not affected by *Dispel Magic* spell.

**...Electrical Storm to Incinerate All Before Me** **Duration:** Instant, *Special*

20 Temporary Power Points

1 Permanent Power Points

This spell allows the caster to throw ten bolts of lightning doing 16 points of magical lightning damage each. If the caster moves or takes damage then they will loose whatever bolts of lightning they have not yet thrown. The caster may pivot on their right foot while this spell is active without ending the spell. The caster has the option to throw all the bolts of lightning at once or one at a time or any combination they want.

**Healing School*****Special Rules for the Healing School***

If your character knows how to cast any Healing spells, you must be aware of all the logistical responsibilities involved. The necessary tag exchanges are described below, but you should read the Playing the Game Chapter for more details.

Healing magic that harms undead does double the normal damage. For example, a Heal Person spell that would normally heal for 12 Body Points would do 24 points of direct body damage to the undead character. Like with any spell, the caster should not double the damage when calling the effect of their spell, the player of the undead character will do the appropriate modifications themselves. If a spell does not list a special affect for undead characters, then it has no effect.

**1<sup>st</sup> Rank Healing**

Spell Verbal: I Draw Upon the Earth to...

**...Detect Life** **Duration:** Instant

0 Power Points,

1 Power Point if Thrown

This spell informs the caster of the state of a character's health. *Detect Life* can be used to determine if a character is truly dead or just faking it, is Unconscious, Bleeding to Death, Mortally Wounded, at the Brink of Death, or Dead and can be used to determine whether a character is undead. This spell can also be used to determine how hurt a character is. The target character of the spell should state how many Body Points they have lost. This spell cannot reveal a *Feign Death* spell or if the character has any parasitic or symbiotic life forms in them.

The *Detect Life* spell costs no Power Points if the caster is touching the character; the spell costs 1 Power Point if the caster tosses a spell packet at the character.

**...Heal this Person** **Duration:** Instant

3 Body Points per 1 Power Point,

Variable

This spell will cure 3 Body Points for every Power Point spent by the caster. When the spell is cast, the caster must state the number of Body Points being cured; for example, "I Draw Upon the Earth to

Heal This Person... Fifteen Body Points” cures 15 Body Points and means that the caster spent 5 Power Points. Characters may not be healed above their normal Body Point maximum.

This spell will damage undead. For every point that would normally be cured, an undead will take 2 Body Points of damage.

## 2<sup>nd</sup> Rank Healing

Spell Verbal: I Draw Upon the Earth to...

**...Purify Blood** **Duration:** Instant  
2 Power Points

This spell will undo the effects of most poisons and alchemical items the character is currently affected by, including intoxication. All applicable poisons or alchemical items are removed with one application of this spell.

**...Assess Your Ailment** **Duration:** Instant  
4 Power Points

By means of this spell, the caster can assess a character's condition revealing more than a *Detect Life* spell. This spell will reveal: if the character is alive, what stage in their Death Count they are at, how many Body Points they are down, if they are poisoned, diseased, and if they are waylaid. It will also reveal how much time has elapsed in the character's Death Count. This spell will also reveal any additional parasitic or symbiotic life forms inhabiting the character. This spell will not reveal more specific information such as what kind of poison or disease is affecting the character.

*For example, Pierre has been paralyzed by some ghouls and is currently Bleeding to Death. Additionally, while he was laying there, a necromancer cast a Cause Disease spell upon him. Nimue casts an Assess Your Ailment spell upon him. Pierre responds by telling Nimue, "I am Bleeding to Death for 30 seconds, poisoned, diseased and down 9 Body Points." Nimue begins to cast the necessary healing spells to restore Pierre.*

**...Heal This Body** **Duration:** Instant  
4 Power Points

This spell will cure most diseases, including the one caused by the *Cause Disease* and *Plague* spells. It will also undo the effects of a *Paralysis* or *Weaken* spell.

*Heal Body* has only one effect each time it is cast; you cannot both cure someone of a disease and paralysis with a single use of the spell.

**...Heal This Mind** **Duration:** Instant  
4 Power Points

This spell will undo the effects of an *Enfeeble* spell. It may also cure insanity, amnesia, and possession; a Plot Marshal will determine whether the *Heal Mind* is successful. This spell will also cure the affects of fear, but the caster must be out of Line of Sight with the source of the fear affect before they can cast it on themselves.

This spell has no affect on the Hypnosis skill, any Charm School spell, Rage skill, or charm like effect.

*Heal Mind* has only one effect each time it is cast; you cannot both cure someone of amnesia and of an *Enfeeble* with a single use of the spell.

## 3<sup>rd</sup> Rank Healing

Spell Verbal: I Draw Upon the Earth to *Aid Me and...*

**...Heal this Limb** **Duration:** Instant  
5 Power Points

This spell will restore a limb or body part that was severed or incapacitated even the head. A new limb is regenerated; it is not necessary to “re-attach” the severed limb. *Heal Limb* restores a limb that was damaged with a Stunning Blow. It will also undo the effects of a *Take Your Sight* spell or a *Mute* spell. It will not re-grow “dead” body parts like hair.

*Heal Limb* has only one effect each time it is cast; you cannot both cure someone of a broken arm and of a *Take Your Sight* with a single use of the spell.

**...Heal this Mortal Wound** **Duration:** Instant  
6 Power Points

This spell will restore a character who is Mortally Wounded, by the Slay or Assassinate skill for example, to 1 Body Point.

**...Return Your Spirit** **Duration:** Permanent  
6 Power Points

This spell will resurrect a character and restore all their Body Points. A substantial portion of the character's body must be available and the head must be attached; the character's spirit must be willing to be resurrected. For the *Return Spirit* spell to work, the caster must be in contact with the body for a full 10 minutes. The Death System must be used to determine whether *Return Spirit* is successful, and therefore the death must be recorded on the player's Character Card. Players who cast a *Return Spirit* spell must use the Power Point tags used in casting the spell to replace any Body Point tags of the target character.

To cast this spell, you must keep your hand on the target character's torso for the full 10 minutes. If you are attacked or are forced to run away during the time it takes to cast this spell, then the Power Points are lost and the spell does not work. Out-of-game, you may remove your hand to help the player pick a stone from the resurrection bag, write on Power Point tags, etc.

Characters restored by *Return Spirit* suffer the normal consequences of the Death System.

A character healed by a *Return Spirit* is restored to the state of health they had when last alive: broken limbs, diseases, amnesia, insanity, intoxication, etc. The *Return Spirit* spell is not a substitute for any other spell of the Healing school.

*Return Spirit* has no effect on an undead. If a character has been turned into a lesser undead and then killed, *Return Spirit* will not resurrect the character; the player must go to the Healers Guild to be resurrected.

The difference between this spell and *Heal Life* is that *Return Spirit* will work on a body no matter how long the character has been dead, restores the character to full Body Points, and requires use of the death system; *Heal Life* only works within a limited amount of time, restores the character to 1 Body Point, and does not use the Death System.



**...Bring this Ghoul to Life**      **Duration:** Instant  
8 Power Points

This spell will turn a character that has been made into a Ghoul back to life. The character cannot have been a Ghoul longer than 1 hour. The character is at 0 Body Points and will wake up in 5 minutes if left alone.

Ghouls that were created spontaneously or by means other than casting the *Create Ghoul* spell on a character are destroyed by this spell. Greater Ghouls and Ghoul Lords are not affected by this spell.

#### 4<sup>th</sup> Rank Healing

Spell Verbal: I Draw Upon the Earth to *Aid Me and...*

**...Heal this Life and Reclaim This Spirit**      **Duration:** Instant  
12 Power Points

This spell will restore a character back to life from the Brink of Death and leaves them at 1 Body Point; the Death System is not used. *Heal Life* must be cast on the character's body within 5 minutes – 10 minutes if the character has the Coma skill – of their character going to the Brink of Death. The character's body must be relatively intact and the head must be attached.



*Heal Life* will only work on a character once per day – a period of time from 7am to 7am the next day. When you cast *Heal Life* on a character, you should write “Life” on their Character Card along with the date, time and your initials; this allows another player to verify whether the character has already been lifed earlier that day. If the spell is cast on a character twice in the same day, the second use has no effect.

A character restored by a *Heal Life* is restored to the state of health they had when last alive: broken limbs, diseases, amnesia, insanity, intoxication, etc. The *Heal Life* spell is not a substitute for any other spell of the Healing school.

*Heal Life* is the equivalent of a *Kill* spell to an undead. If a character has been turned into an undead and then killed, *Heal Life* will not restore the character.

The difference between this spell and *Return Spirit* is that *Return Spirit* will work on a body no matter how long the character has been dead, restores the character to full Body Points, and requires use of the death system; *Heal Life* only works within a limited amount of time, restores the character to 1 Body Point, and does not use the Death System.

This spell cast upon a living character, a character that is Bleeding to Death, or a character who is Mortally Wounded has no effect and does not use up that character's ability to receive a *Life* spell for that day.

**...Purge this Death Slave of Their Necromantic Taint and Restore Their Will**      **Duration:** Instant  
20 Power Points

This spell will turn a character that has been made a Death Slave back to life and at the Brink of Death. They begin their Death Count normally and must receive the appropriate healing in the normal time.

**...Heal this Person and Restore them to Full Health**      **Duration:** Instant  
14 Power Points

This spell will totally restore the target character's Body Points. Additionally, this spell will also act as a *Purify Blood*, *Heal Mind*, *Heal Body*, and *Heal Limb* spells. Additionally, for the last three effects, all ailments or limbs are restored, not just one as in the spells of the same name.

This spell will not heal a person's Body Points if they are past the Bleeding to Death stage, however the rest of the spell will still take affect normally.

This spell does 50 direct Body Points of damage to a character hurt by the element of Life – such as undead characters. Undead characters still take double damage from this spell, i.e. 100 points of damage.

## Ice School

### *Special Rules for the Ice School*

There are no special rules for the Ice School.

### 1<sup>st</sup> Rank Ice

Spell Verbal: By the North Mist I Form a(n)...

**...Ice Dart** **Duration:** Instant  
2 Power Points

This spell does 8 points of magic damage due to ice.

**...Frost Brand** **Duration:** Latent  
2 Power Points

This spell can only be cast on a weapon. If you hold the weapon, you can invoke this spell, which causes the next weapon attack done by the weapon to be ice based. *Frost Brand* does not make the attack magical and it does not add any damage to the weapon. The attacker declares a blow to be ice based by adding the word “ice” to the damage done by the attack; for example: “Two Ice.” *Frost Brand* only lasts for one blow, but if an attacker fails to hit their target the spell is not used up. *Frost Brand* can be combined with any martial skill such as Weapon Proficiencies, Slay, Assassinate, Critical Attack, Waylay, etc.

**...Ice Cast** **Duration:** 30 Seconds  
3 Power Points

This spell can be used to immobilize one arm, leg, wing, tail or tentacle. The limb cannot be used for 30 seconds. The ice cast can be broken with a +3 or greater Strength Bonus, Non-Combinable and takes 5 seconds. If the target character is immune to the *Pin* spell due to their Strength Bonus, they are immune to this spell as well. The caster should state what limb is affected when they cast the spell, “By the North Mist I Form an Ice Cast... right arm,” but the name of the limb is not part of the spell verbal. If the caster does not specify which limb is being frozen, the target character must choose a limb to be immobilized.

While the limb is encased in ice, any blow on that limb will affect the character normally, leaving the ice cast unharmed. For example, a Stunning Blow to the limb will not shatter the ice cast, but this will incapacitate the limb as per a normal Stunning Blow. The ice itself is magical and therefore a *Dispel Magic* will remove the *Ice Cast* spell.

The ice from this spell sublimates when removed or the spell ends.

### 2<sup>nd</sup> Rank Ice

Spell Verbal: By the North Mist I Form a *Freezing*...

**...Ice Shield** **Duration:** Latent  
3 Power Points

When invoked, this spell will cancel the effects of one Ice School spell. The *Ice Shield* spell will also negate one blow from a weapon that does normal or magical ice or water damage but will not stop special damaging martial attacks such as the Slay, Critical Strike, Stun, Assassinate, etc. skills. An *Ice Shield* will protect against extreme non-magical cold for 5 seconds.

**...Ice Bolt** **Duration:** Instant  
4 Power Points

This spell does 16 points of magic damage due to ice.

**...Preservation** **Duration:** While the Caster  
5 Power Points Maintains Contact with  
the Target

This spell is cast on a character that is Bleeding to Death, Mortally Wounded or at the Brink of Death. While a hand of the caster is touching the target, the target’s Death Count pauses. This spell does not require concentration, just contact between caster and target. Should the caster be rendered unconscious or they remove their hand the spell is broken.

The maximum number of characters the caster can preserve at once is two.

### 3<sup>rd</sup> Rank Ice

Spell Verbal: By the North Mist I Form a *Freezing Cold*...

**...Spear of Ice** **Duration:** Instant  
6 Power Points

This spell does 24 points of magic damage due to ice.

**...Wall of Frost** **Duration:** While  
6 Power Points Concentrating

This spell creates a 10 foot by 10 foot by 1 foot wall of frost; if anyone touches or passes through the *Wall of Frost* spell they take 14 points of magical damage due to ice.

This spell follows the normal rules for walls described earlier in this chapter.

### 4<sup>th</sup> Rank Ice

Spell Verbal: By the North Mist I Form a *Freezing Cold*...

**...Arctic Wind to Stun You** **Duration:** 10 Seconds  
10 Power Points

This spell causes the targeted character to be Torso Stunned for 10 seconds.

**...Icy Imprisonment** **Duration:** 1 Hour  
10 Power Points

This spell will turn a character to ice. This spell can only be cast upon a character that is in their Death Count. This spell only affects the character’s body not their possessions or clothing. While under the effects of this spell, the character is in stasis and their Death Count and all other timed effects – alchemical durations, diseases, Death Slave, etc. – stop. Only normal strength is needed to move the character.

This spell will end after 1 hour, the caster ends the spell, or a *Dispel Magic* is cast upon the character.

### 5<sup>th</sup> Rank Ice

Spell Verbal: By the North Mist I Form a *Freezing*...

**...Arctic Maelstrom to Rend my Enemies with the Bone Chilling Power of Ice** **Duration:** Instant, *Special*

20 Temporary Power Points  
1 Permanent Power Points

This spell allows the caster to throw 10 bolts of ice doing 16 points of magical ice damage each. If the caster moves or takes damage then they will lose whatever bolts of ice they have not yet thrown. The caster may pivot on their right foot while this spell is active without ending the spell. The caster has the option to throw all the bolts of ice at once or one at a time or any combination they want.

## Necromancy School

### Special Rules for the Necromancy School

Necromancy involves the creation and control of undead. There are different categories of undead: lesser undead are creatures that are relatively easy for necromancers to create, such as those listed in the spells below, or some Sorcery rituals. The lesser undead are: Zombies, Skeletons, Ghouls, Revenants, Specters, Wraiths, Wights, Shadows, Shades, and “Superior” versions of these prior undead. Greater undead are more difficult to create and control and are always intelligent; they are: Death Slaves, Vampires, Death Knights, Death Assassins, Death Mages, Mummies, Liches, and any “Lord” undead such as Zombie Lords or Death Lords.

There are five types of undead that can be created with magic spells: Zombies, Skeletons, Ghouls, Revenants, and Death Slaves. All other forms of undead are created by ritual magic, which players must learn about in-game or are spontaneously created. When your character learns Necromancy, you must carry any costuming and claws for the undead you wish to create and their approved undead Character Card.

**No undead creation spell can be cast on a body in sunlight.** The *Create Zombie*, *Create Skeleton*, and *Create Revenant* spells work in two ways. First the character can cast it on an already dead corpse of the appropriate type. The second method allows the character to cast the spell on a character in their Death Count, “infecting” them with the creation spell. When character reaches the end of their Death Count, they will be raised as the appropriate type of undead.

If a caster creates an undead with a necromantic spell, they have control over it. The creatures made by *Create Zombie*, *Create Skeleton*, *Create Ghoul*, and *Create Revenant* are mindless undead; they can obey simple commands for example: “Guard me,” “Give all your possessions to that soldier,” “Walk around this cemetery and attack all living things but me,” but they cannot do anything that requires creative thought or forces them to make a decision, for example, “Establish a defensive perimeter,” “Guard my friends but attack my enemies,” “If I die, carry my body back to the Necromancer’s Guild.”



All undead are hurt by *Heal Person* and by *Heal Life* spells, and can be healed by certain spells of the Death School. *Heal Life* is never a saving grace for a living character that has been turned into an undead; the only common way an undead character can be brought back to life is through some Healing School spell or to be resurrected at the Healers Guild. There may exist other lost magical spells or sorcery rituals that can bring the character back from being undead.

If *Sever Magic* is used on the caster to cancel their control over their undead, they will continue to follow and carry out their last commands. If they did not have any specific commands, then the undead revert to their normal behavior: attack and slay all living things including their creator. If another caster uses a *Command Undead* to issue a command, the original creator may override that command if they are present; the original caster just has to speak for the undead to obey.

If your character is turned into an undead, then a death must be recorded on your character card when you are resurrected, and you will suffer the normal consequences of the Death System.

All of the undead created in this school, unless noted in the spell description, will last for 1 hour then turn to dust. However, if the character is un-resurrectable, the effect is permanent until destroyed. **As with all spells, the undead creation spells do not last past the end of an Event, so if a character is undead at the end of an Event, they are not undead at the beginning of the following Event. However, the player must still go to the Healer’s Guild and resurrect normally, unless their character is un-resurrectable.**

### 1<sup>st</sup> Rank Necromancy

Spell Verbal: I Control Chaos to...

#### ...Feign Life

**Duration:** 10 Minutes

1 Power Point

This spell will make an undead character look alive; their skin will be a normal, healthy color and feel warm to the touch; they will appear to have a normal pulse and breath. A *Detect Life* spell, *Assess Your Ailment* spell or the First Aid skill will not reveal that the character is dead. *Feign Life* will only work on undead whose bodies are intact; the skeletal class of undead or non-corporeal undead cannot impersonate a living being with this spell.

#### ...Cause Disease

**Duration:** 6 Hours

2 Power Points

This spell causes the target to contract a deadly disease and immediately loses 1 Body Point and swings 1 point of damage less, then the character will begin to lose an additional 1 Body Point and swing 1 point of damage less every 10 minutes. The character will stop losing Body Points at 1 Body Point and will always swing a minimum of 1 point of damage. The effects of this spell are not cumulative with other *Cause Disease* spells and the Body Points lost due to this spell cannot be healed until the disease is cured.

*For example, Orion has 10 Body Points and does 4 points of damage with his sword. He is hit with this spell and is not healed right away. After 30 minutes, he has 6 Body Points and swings 1 point of damage. After 80 minutes, he has 1 Body Point and would still swing for 1 point of damage.*

The target will be at the Brink of Death at the end of 6 hours unless a *Heal Body* spell or similar effect is cast on them.



**...Create a Zombie****Duration:** *Special*

2 Power Points

When cast on a **dead body**, this spell will turn the corpse into a Zombie. The body must have been dead for less than five days.

If this spell is cast upon a character in their Death Count, the character is infected with the creation spell and will be turned into a Zombie when the character reaches the end of their Death Count.

<b>Minor Zombie (Lesser Undead)</b>	
<b>Body Points:</b>	15
<b>Armor Points:</b>	As Worn
<b>Power Points:</b>	None
<b>Strength Bonus:</b>	+1, Non-Combinable
<b>Damage Bonus:</b>	+0
<b>Special:</b>	Natural Claws Charm Immunity Alchemical Immunity Immunity: Fear Immunity: Waylay Immunity: Paralysis Touch skill Immunity: Disarm Skill Immunity: Pain Touch Skill Immunity: Venom Touch Skill Harmed by healing magic Double damage from elemental life Healed by elemental death and Necromancy All zombies MUST move and fight slowly. They are unintelligent and can only follow simple commands. They will only attack moving living characters.
<b>Monster Skills:</b>	None
<b>Skills:</b>	Can never learn skills
<b>Alignment:</b>	Evil, Dark Lord's Creation

**...Command Undead****Duration:** 1 Command

3 Power Points

This spell allows the caster to give a single command that will be obeyed by all lesser undead who hear it. The command must be a single sentence, and it must be simple enough for a mindless undead to obey. The command cannot be "Obey my commands" or some similar command. No wishing for more wishes.

**2<sup>nd</sup> Rank Necromancy**Spell Verbal: I Control Chaos *and Evil* to...**...Create a Skeleton****Duration:** *Special*

3 Power Points

When cast on a skeletal **dead body**, this spell will turn it into a Skeleton. This spell will work on any corpse regardless of how long it has been dead, the bones of a fresh corpse will tear out of the body leaving the flesh behind.

If this spell is cast upon a character in their Death Count, the character is infected with the creation spell and will be turned into a Skeleton when the character reaches the end of their Death Count.

**Minor Skeleton (Lesser Undead)**

<b>Body Points:</b>	15
<b>Armor Points:</b>	As Worn
<b>Power Points:</b>	None
<b>Strength Bonus:</b>	+1, Non-Combinable
<b>Damage Bonus:</b>	+0
<b>Special:</b>	Natural Claws Charm Immunity Alchemical Immunity Immunity: Fear Immunity: Waylay Immunity: Paralysis Touch skill Immunity: Disarm Skill Immunity: Pain Touch Skill Immunity: Venom Touch Skill Harmed by healing magic Double damage from elemental life Healed by elemental death and Necromancy Skeletons move at normal speed. They are unintelligent and can only follow simple commands. They will only attack moving living creatures.
<b>Monster Skills:</b>	Weapon Skill of Choice
<b>Skills:</b>	Can never learn skills
<b>Alignment:</b>	Evil, Dark Lord's Creation
<b>Costume:</b>	

**...Rot Flesh****Duration:** Instant

5 Power Points

This spell does 15 points of magical rot damage. If cast on an undead, *Rot Flesh* will restore 15 Body Points; however, the spell cannot restore destroyed lesser undead.

**...Wither Limb****Duration:** Instant

6 Power Points

This spell will cause an arm or leg to wither and become useless. The caster can specify an arm or leg to affect when the spell is cast, however if the caster fails to specify a limb, the target character must choose one to be affected. The target character does not suffer any Body Point loss from this spell.

The affects of this spell are permanent until healed by a *Heal Limb* spell. A *Dispel Magic* spell has no effect on a withered limb.

**3<sup>rd</sup> Rank Necromancy**Spell Verbal: I Control Chaos *and Evil from my Heart* to...**...Create a Ghoul****Duration:** *Special*

8 Power Points

When cast on an Unconscious body, this spell will turn them into a Ghoul. The body must be Unconscious at 0 Body Points. A body that is unconscious solely due to a Waylay or a spell will not be affected by *Create Ghoul*; a character that is Bleeding to Death, Mortally Wounded or at the Brink of Death will also be unaffected.

Minor Ghoul (Lesser Undead)	
<b>Body Points:</b>	18
<b>Armor Points:</b>	As Worn
<b>Power Points:</b>	None
<b>Strength Bonus:</b>	+1, Non-Combinable
<b>Damage Bonus:</b>	+2
<b>Special:</b>	Natural Claws Paralysis Poisoned Claws Claws swing for Paralysis poison Charm Immunity Alchemical Immunity Immunity: Fear Immunity: Waylay Immunity: Paralysis Touch skill Immunity: Disarm Skill Immunity: Pain Touch Skill Immunity: Venom Touch Skill Harmed by healing magic Double damage from elemental life Healed by elemental death and Necromancy All Ghouls move at normal speed. They are cunning fighters and can follow multiple simple commands. They will normally only attack living creatures. When left to their own devices, will eat the flesh of their victims.
<b>Monster Skills:</b>	None
<b>Skills:</b>	Can never learn skills
<b>Alignment:</b>	Evil, Dark Lord's Creation
<b>Costume:</b>	

**...Dominate Undead** **Duration:** 1 Hour  
9 Power Points

When an undead is affected by this spell, it will obey all the commands given by the caster. This spell will affect all undead, including greater undead. However, intelligent undead cannot be ordered to kill themselves; they will also remember who cast the spell on them and may seek vengeance once the spell has worn off. A *Dominate Undead* spell will work on a Death Slave. Unlike the Charm School spells, the affected, intelligent undead character may attack the caster if they wish.

**...Shield from Sunlight** **Duration:** Until Sundown  
9 Power Points

When this spell is cast on an undead, it is no longer harmed or repelled by sunlight. *Shield from Sunlight* can be cast from the time light first shows in the sky through sunset; it does not work if cast at night.

**...Cripple You with the Plague** **Duration:** 5 Minutes  
9 Power Points

This spell causes the target character to be instantly infected with a debilitating, non-contagious plague for 5 minutes or until cured with a *Heal Body* spell or effect. While under the effects of this spell, the character looks pasty, weak and sickly. They have a fever and feel warm to the touch. The character will swing for 1 point of damage, is reduced to 1 Body Point until the spell ends, cannot use any Advanced Career skill except for Faith skills, and can only move at a normal walking pace.

At the end of the 5 minutes, if the character is not healed of the plague, they will be brought to the Brink of Death and the spell ends.

If the character dies from the Plague spell, they will rise up as a Superior Skeleton.

#### 4<sup>th</sup> Rank Necromancy

Spell Verbal: I Control Chaos *and Evil from my Heart* to...

**...Decay Flesh and Bones** **Duration:** Instant  
10 Power Points

This spell does 30 points of magical rot damage. If cast on an undead, *Decay Flesh and Bones* will restore 30 Body Points; however, the spell cannot restore destroyed lesser undead.

**...Create a Revenant** **Duration:** *Special*  
12 Power Points

When cast on a large corpse, this spell will turn it into a Revenant. *Create Revenant* requires a substantial portion of the body of a large creature such as: Ogres, Giants, Adult Trolls, Colossal Trolls, Titans, etc.; it does not work on a human body, no matter how tall it is.

If this spell is cast upon a character in their Death Count, the character is infected with the creation spell and will be turned into a Revenant when the character reaches the end of their Death Count.

Minor Revenant (Lesser Undead)	
<b>Body Points:</b>	60
<b>Armor Points:</b>	As Worn
<b>Power Points:</b>	None
<b>Strength Bonus:</b>	+3
<b>Damage Bonus:</b>	+1 with claws only
<b>Special:</b>	Natural Claws Charm Immunity Alchemical Immunity Immunity: Fear Immunity: Waylay Immunity: Paralysis Touch skill Immunity: Disarm Skill Immunity: Pain Touch Skill Immunity: Venom Touch Skill Harmed by healing magic Double damage from elemental life Healed by elemental death and Necromancy Damage Resistance: Silver All Revenants move at a slow speed, but fight normally. They are cunning fighters and can follow complex commands. They will normally only attack living creatures.
<b>Monster Skills:</b>	Weapon Skill of Choice
<b>Skills:</b>	Can never learn skills
<b>Alignment:</b>	Evil, Dark Lord's Creation
<b>Costume:</b>	

**...Create a Death Slave Who Will Obey my Each and Every Whim**      **Duration:** 1 Hour

20 Power Points

This spell turns a character – with the exception of undead, constructs or other characters as indicated on their Character Card – into a Death Slave, a special form of greater undead. The Death Slave has all the abilities, knowledge, and skills the character had when alive. Death Slaves are completely obedient to their creators, and will obey their creators' commands with all their intellect and creativity; for example, "Trick your best friend into stealing the Queen's crown." Death Slaves know who controls them, but they will not reveal their controller unless the revelation fits in with the controller's commands.

The targeted character is brought to full Body Points and all limbs are healed when affected by a *Death Slave* spell. Even if the character was at the Brink of Death, they will be turned into a Death Slave at full Body Points. Note that this does not use up one of the characters life effects for the day as they are turned into an undead not lifed.

When the character is brought back to life they recall everything they did during the time they were a Death Slave and they remember who cast the *Death Slave* spell on them. They retain their memory even if they are killed before their hour of undead existence is over. The character's death must be recorded on their character card.

Should the caster die or be affected by a *Sever Magic* spell, the Death Slave will continue to carry out any orders it was already given; otherwise, it will act according to its own volition. A *Dominate Undead* will override a creator's control over their Death Slave.

Death Slaves have the normal Death Count their character had while alive. A Death Slave will only exist for 1 hour. During that time the character looks obviously undead with pale rotting flesh. After 1 hour, the Death Slave turns to dust, even if they are being persevered by an *Icy Preservation* spell.

Death Slave (Greater Undead)	
<b>Body Points:</b>	+50
<b>Armor Points:</b>	As Worn
<b>Power Points:</b>	+0
<b>Strength Bonus:</b>	+2
<b>Damage Bonus:</b>	+2, with claws
<b>Special:</b>	Natural Claws Charm Immunity Alchemical Immunity Immunity: Fear Immunity: Waylay Immunity: Paralysis Touch skill Immunity: Disarm Skill Immunity: Pain Touch Skill Immunity: Venom Touch Skill Damage Resistance: Silver Harmed by healing magic Double damage from elemental life Healed by elemental death and Necromancy All Death Slaves move and fight normally. They are intelligent and can follow any command.
<b>Monster Skills:</b>	None
<b>Skills:</b>	Skills character had in life
<b>Alignment:</b>	Evil, Dark Lord's Creation
<b>Costume:</b>	<i>Special</i>

## 5<sup>th</sup> Rank Necromancy

Spell Verbal: I Control Chaos *and Evil from my Heart* to...

**...Raise all the Dead Who Rest in this Graveyard to Serve my Each and Every Whim**      **Duration:** Until Destroyed

30 Temporary Power Points

2 Permanent Power Points

This spell can be cast anywhere, not just a graveyard as the name implies, and will raise 100 lesser undead. The specific undead raised is up to the Plot Committee, but they will be a mix of what is listed below.

Lesser Undead	Up to...
Zombie	80%
Skeleton	60%
Ghoul	40%
Revenant	20%
Specter	10%
Wraith	10%

The undead are under the control of the caster and will remain until destroyed.





## Pyrotechnics School

### Special Rules for the Pyrotechnics School

Except for the *Match* spell, Pyrotechnics spells do not create actual fires. The flames do magical damage and do not actually burn anything; a caster can hurt a character with a *Fireball* spell, but they cannot use *Fireball* to set a house on fire.

### 1<sup>st</sup> Rank Pyrotechnics

Spell Verbal: I Summon Forth an Eldritch...

#### ...Light Duration: *Special*

0 Power Points

1 Power Point if Thrown

This spell causes an object long sword or smaller to glow. This spell has no effect on most characters. *Light* costs no Power Points if the caster is touching the object or 1 Power Point if the caster throws the spell. The character holding the light spell may extinguish the light by covering it with their hand, but they cannot restore the light again without another *Light* spell.

Out-of-game, a small flashlight that must be supplied by the player represents the *Light* spell for each *Light* spell cast. If there is no flashlight then the spell will not work. However, if the player casts this spell during the out-of-game daytime, the caster gets one free *Light* spell without the need for a flashlight. The *Light* spell lasts until the flashlight's batteries run out. Even if you have replacement batteries, the *Light* spell must be recast after the new batteries are installed.

#### ...Match Duration: Until the Flame Burns Out

0 Power Points

1 Power Point if Thrown

This spell causes the tip of a piece of wood to burst into flame. The piece of wood can be no larger than 2 feet by 2 inches by 2 inches. You may light an actual match or torch if a Marshal permits and if it is permitted by the rules of the campsite. Otherwise, you must use some representation of the torch and, if necessary, a Marshal will note that the wood is on fire.

#### ...Flare Duration: Instant

2 Power Points

This spell does 8 points of magical damage due to fire.

#### ...Fire Brand Duration: Latent

2 Power Points

This spell can only be cast on a weapon. If you hold the weapon, you can invoke this spell, which causes the next weapon attack done by the weapon to be fire based. *Fire Brand* does not make the attack magical and it does not add any damage to the weapon. The attacker declares a blow to be fire based by adding the word "Fire" to the damage done by the attack; for example: "Two Fire." *Fire Brand* only lasts for one blow, but if an attacker fails to hit their target the spell is not used up. *Fire Brand* can be combined with any martial skill such as Weapon Proficiencies, Slay, Assassinate, Critical Attack, Waylay, etc.

### 2<sup>nd</sup> Rank Pyrotechnics

Spell Verbal: I Summon Forth an Eldritch...

#### ...Fire Shield Duration: Latent

3 Power Points

When invoked, this spell will cancel the effects of one Pyrotechnics spell. *Fire Shield* will also negate one blow from a weapon that does normal or magical flame damage but will not stop special damaging

martial attacks such as the Slay, Critical Strike, Stun, Assassinate, etc. skills. A *Fire Shield* will protect against extreme non-magical heat such as molten lava for 5 seconds.

#### ...Fireball Duration: Instant

4 Power Points

This spell does 16 points of magical damage due to fire.

#### ...Inferno Duration: Instant

6 Power Points

This spell does 24 points of magical damage due to fire.

### 3<sup>rd</sup> Rank Pyrotechnics

Spell Verbal: I Summon Forth an Eldritch *and Fiery*...

#### ...Wall of Flame Duration: While Concentrating

6 Power Points

This spell creates a 10 foot by 10 foot by 1 foot wall of fire; if anyone touches or passes through the *Wall of Flame* spell they take 14 points of magical damage due to fire.

This spell follows the normal rules for walls described earlier in this chapter.

#### ...Dragon's Breath Duration: Instant

8 Power Points

This spell does 32 points of magic damage due to fire.

### 4<sup>th</sup> Rank Pyrotechnics

Spell Verbal: I Summon Forth an Eldritch *and Fiery*...

#### ...Lava Burst to Burn My Enemies Duration: Instant

12 Power Points

This spell does 48 points of magic damage due to fire.

### 5<sup>th</sup> Rank Pyrotechnics

Spell Verbal: I Summon Forth an Eldritch *and Fiery*...

#### ...Meteor Swarm to Destroy my Enemies with the Power of Fire Duration: Instant, *Special*

20 Temporary Power Points

1 Permanent Power Points

This spell allows the caster to throw 10 balls of fire doing 16 points of magical fire damage each. If the caster moves or takes damage then they will loose whatever balls of fire they have not yet thrown. The caster may pivot on their right foot while this spell is active without ending the spell. The caster has the option to throw all the balls of fire at once or one at a time or any combination they want.

#### ...Volcano to Smite Down my Foes with the Raging Power of the Deep Fires of the Earth Duration: Instant, *Special*

30 Temporary Power Points

2 Permanent Power Points

This spell allows the caster to throw 10 balls of fire doing 24 points of magical fire damage each. If the caster moves or takes damage then they will loose whatever balls of fire they have not yet thrown. The caster may pivot on their right foot while this spell is active without ending the spell. The caster has the option to throw all the balls of fire at once or one at a time or any combination they want.

## Thaumaturgy School

### Special Rules for the Thaumaturgy School

The *Detect Magic*, *See Magic*, *Identify Magic*, *Detect Curse*, and *Know Your Curse* spells have a logistical limitation. If there is no one present who, out-of-game, can inform the caster of the magical properties of an item, then these spells do not work but do not cost the character any Power Points. Also, the first three spells cannot detect the presence or effects of alchemical items.

Thaumaturgy spells work the same on low magic, Nature Magic and Spell Singing. Many work normally on most sorcery rituals.

The word “thaumaturgy” is pronounced “THAW-ma-tur-jee.”

### 1<sup>st</sup> Rank Thaumaturgy

Spell Verbal: I Pierce the Veil to...

**...Detect Magic** **Duration:** Instant  
0 Power Points  
1 Power Point if thrown

This spell will identify if an object is magical. The spell costs no Power Points if the caster is touching the object; the spell costs 1 Power Point if the caster tosses a spell packet at the object.

**...See Magic** **Duration:** Instant  
1 Power Point

This spell will cause all magic within 5 feet to glow with a cerulean color; the 5 feet is measured from the point of impact of the spell packet. Magic items, scrolls, and characters with latent or active spells will all glow briefly. Only the caster can see this glow and the glow is the same regardless of the power level of the magic. The glow cannot be hidden by an intervening object; a magic ring cannot be protected from a *See Magic* by hiding it in a pouch.

A defense against magic will stop the spell if cast directly at a character, but if the spell is targeted at an inanimate object or if a character is in the area of effect, they can only invoke an *Obscure* spell to stop the effect. If they are not the target of the spell, they will only know that the *See Magic* was cast in their area if they have an *Obscure* upon them, and then they will only know that the spell was cast, not who cast it.

**...Know Your Magic** **Duration:** Instant  
2 Power Points

This spell will reveal to the caster all the spells that are currently affecting that person. The caster gets to look at all the latent spells on the target character. If the character has any active spells affecting them – *Dominate*, *Enfeeble*, *Death Slave*, etc. – those are also revealed to the caster. This includes any Warlock augmented spells.

This spell does *not* reveal any rituals or curses that currently affect a character. It does not determine any natural racial or natural magical powers that a creature may possess for example, it cannot determine if an elf can resist a *Sleep* spell. A *Know Magic* spell cannot detect the effects of any alchemical items.

### 2<sup>nd</sup> Rank Thaumaturgy

Spell Verbal: I Pierce the Veil of Force to...

**...Detect Curse** **Duration:** Instant  
3 Power Points

This spell will reveal to the caster whether or not the target character is cursed – as by a werewolf, a vampire, a gypsy, etc. It does *not*

reveal the type of curse or the number of curses on the character, only the fact that a character is cursed.

**...Sever Magic** **Duration:** Instant  
4 Power Points

This spell destroys the magical link between a character and one of the active spells they have cast. The spell must be cast on the character that is actively controlling the spell. *Sever Magic* spell can be used against an *Enslave*, *Dominate*, *Dominate Undead*, *Command Undead*, *Wall of Flame*, *Wall of Force*, the undead creation spells, etc. This spell will not end a spell that does not require concentration, for example, in the case of a *Dominate* spell the character is still dominated and must follow the commands already given. However, spells that do require concentration such as a wall spell will end if the caster is severed from the spell.

Normal defenses against magic do not work against a *Sever Magic* spell, it is the link that is affected, not the caster, but an *Obscure* spell will stop the spell. If the caster has multiple magical links, the caster of *Sever Magic* spell must specify which link is being severed; otherwise the target caster chooses a link to drop.

**...Obscure** **Duration:** Latent  
5 Power Points

When invoked, this spell will protect against one Thaumaturgy spell. For example, if someone casts a *See Magic* spell on a character and they do not want to reveal that they possess any magic items, if the character invokes an *Obscure* spell then the caster will see no magic when they look at the target character.

Important: Unlike most latent spells, an *Obscure* spell does *not* have to be announced when it is invoked; there is no characteristic flash of light when this defense is used. If a player invokes an *Obscure* spell in a manner that is not immediately obvious, they should consult with a Marshal to confirm that the spell was used. For example, if a character uses this spell against a *Detect Curse* spell to avoid suspicion that they are a werewolf, a Marshal should be informed.

An *Obscure* spell cannot protect against nor prevent a *Destroy Magic* or *Disrupt your Defenses* spell.

**...Dispel Magic** **Duration:** Instant  
6 Power Points

This spell undoes the effect of one currently active spell. For example, this spell can cancel the effects of most Bond spells, Charm spells, wall spells, etc. The *Dispel Magic* spell can be cast at the effect of the spell as in the case of *Wall of Force* or *Lock* spells or at the character affected by the spell. When the spell is used against the target character directly, the character should make an out-of-game comment indicating which spell is being canceled; if the caster does not specify, then the target player must choose one active spell to be removed.

*Dispel Magic* does not work against latent spells. It also does not work against *Imprisonment* or *Magic Sanctuary*, and it cannot undo the creation of undead by the Necromancy School.

### 3<sup>rd</sup> Rank Thaumaturgy

Spell Verbal: I Pierce the Veil of Force and Energy to...

**...Drain Magic Power** **Duration:** Instant  
6 Power Points

This spell will cause the target character to lose up to 10 Power Points and transfer the lost points to the caster of the spell. The target cannot lose more Power Points than they have left, and the caster cannot gain more than their normal Power Point maximum. However, if the caster is at his maximum Power Points and the target

has power left, the target character will still loose up to 10 Power Points.

The exchange of Power Point tags is mandatory when this spell is used. If this spell is used on a non-player character that does not have any Power Point tags, then the NPC (not the player!) must take the Power Point tags used to cast the spell, write down the number of Power Points transferred, and sign their out-of-game name.

**...Destroy Magic** **Duration:** Instant  
9 Power Points

This spell destroys all spells with a duration of latent, even those augmented by Warlock skills, on a character. No spell from the Aura School can prevent this; neither can an *Obscure* spell. A *Destroy Magic* spell does not effect active spells such as *Paralysis*, *Imprisonment*, and *Magic Sanctuary* or an active *Fortitude*.

This spell will be stopped by any sorcery ritual that stops spells such as Ritual of Spell Shield. No low magic spell, even one contained in an item, can be used to stop this spell.

**...Quiet Sorcery** **Duration:** Instant  
9 Power Points

This spell will temporarily bring down defensive latent sorcery rituals cast directly upon a target character for 5 minutes. If the target has a magic item that is giving them the benefit of some ritual, such as Ritual of Defense, the ritual will not be affected. No ritual magic, even one contained in an item, can be used to stop this spell.

This spell will be stopped normally by any low magic defense that stops spells such as the *Negation*, *Absorption*, or *Obscure* spells.

**4<sup>th</sup> Rank Thaumaturgy**

Spell Verbal: I Pierce the Veil of *Force and Energy* to...

**...Identify Magic** **Duration:** Instant  
10 Power Points

This spell will reveal to the caster all the magical properties of an object. Out-of-game, this requires that either the caster sees the item's card, or that a Marshal has the information to give to the caster. If you have cast an *Identify Magic* spell on an item, then you know how to use it and can teach someone else how to use it.

In addition, if cast on a person, the spell will reveal all the information gained by a *Know your Magic* spell and what rituals are cast upon a person directly and what they do. If the person has a magic item that is giving them the benefit of some ritual, such as Ritual of Defense, the spell will not reveal such.

This spell will never tell the word to any kind of ward or any other key word an item may have.

**...Identify Your Curse** **Duration:** Instant  
10 Power Points

This spell will reveal to the caster the type and effect of all curses upon the targeted character. For example, if the character has been cursed by a Gypsy to stutter and suffers from werewolf lycanthropy, this spell will reveal that the character is a werewolf and stutters because of a Gypsy curse. This spell will not reveal the source of the curse.

**5<sup>th</sup> Rank Thaumaturgy**

Spell Verbal: I Pierce the Veil of *Force and Energy* to...

**...Disrupt Your Magical Defenses and Kill You Where You Stand** **Duration:** Instant

21 Temporary Power Points

1 Permanent Power Points

A character hit with this spell will lose all latent low magic spells – even ones augmented by Warlock skills – and all latent defensive rituals on the character for 5 minutes. The character will be brought to 0 Body Points if they have any latent low magic spells and the character will be brought to the Brink of Death if they have any warlock augmented spell defenses or any defensive latent rituals. All these spells must be cast upon the character, ones cast in an item do not count. If a character only suffers damage from other effects that brings them to the Brink of Death – *Kill* or *Life* spells for example – they are still brought to the Brink of Death.

Defensive sorcery rituals that stop spells cast from an item can be used to stop this spell and the character suffers no ill effects. No low magic spell, even one contained in an item, can be used to stop this spell.







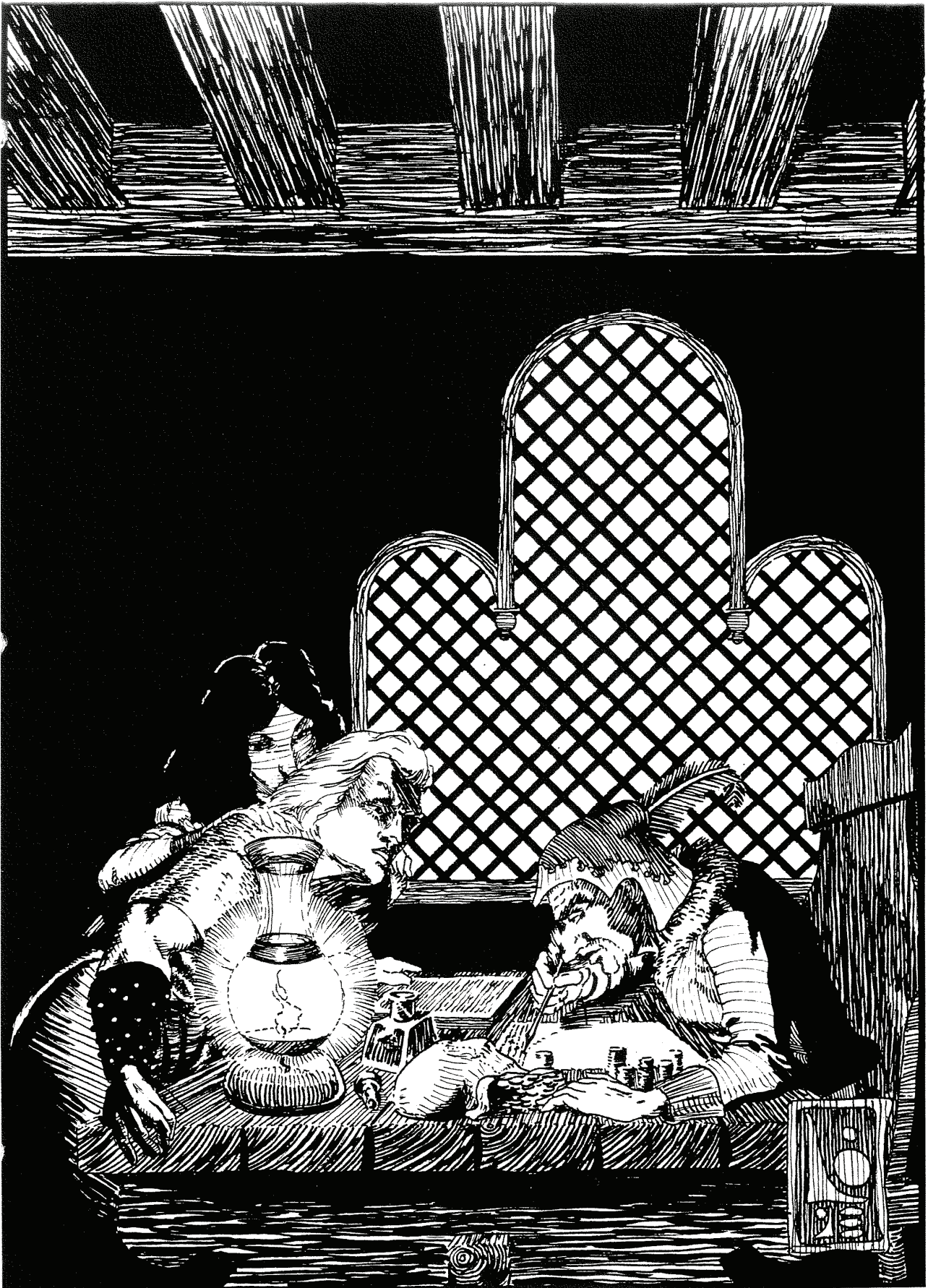



## Chapter 4: Advanced Careers...

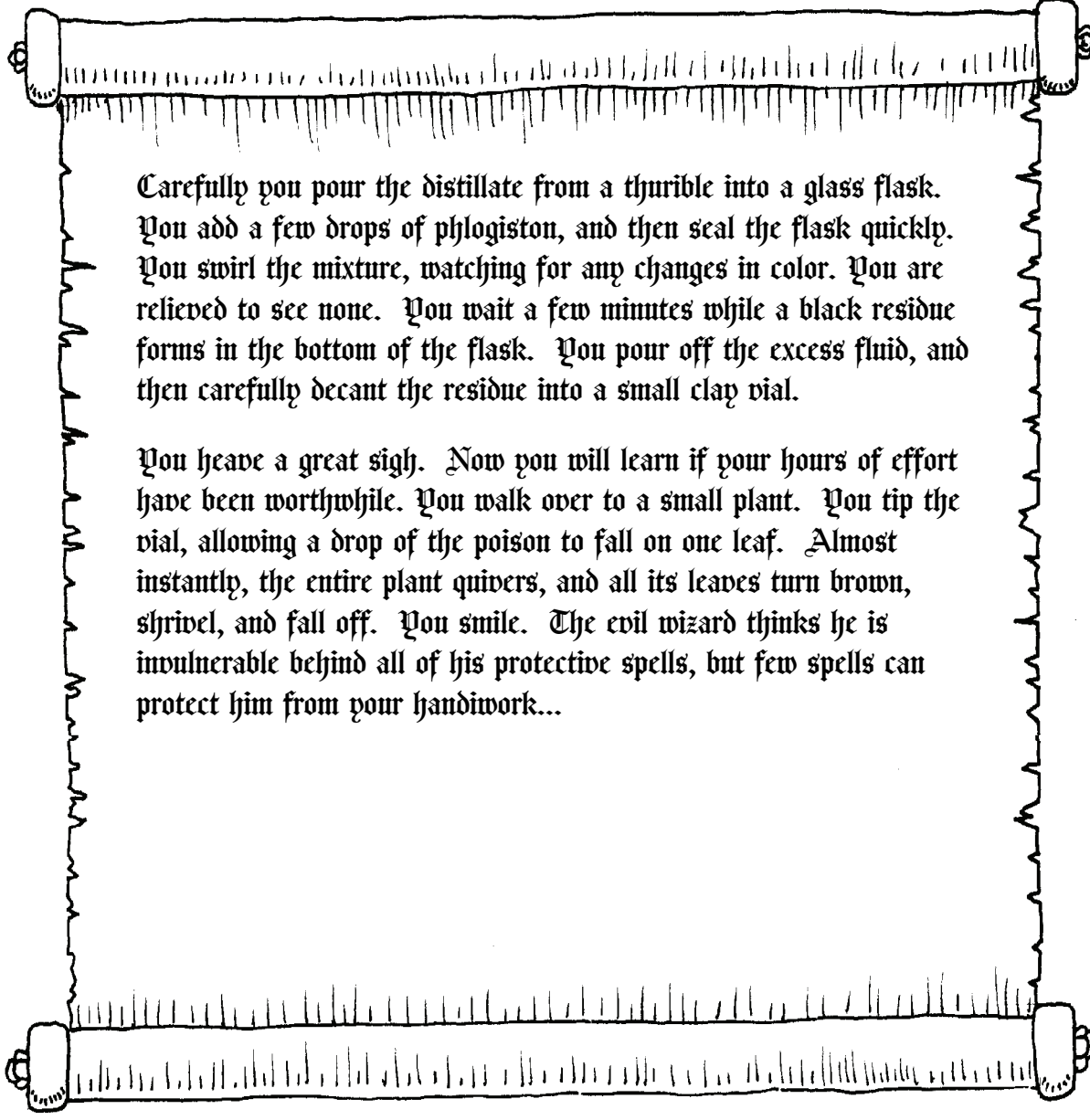

Carefully you pour the distillate from a thurible into a glass flask. You add a few drops of phlogiston, and then seal the flask quickly. You swirl the mixture, watching for any changes in color. You are relieved to see none. You wait a few minutes while a black residue forms in the bottom of the flask. You pour off the excess fluid, and then carefully decant the residue into a small clay vial.

You heave a great sigh. Now you will learn if your hours of effort have been worthwhile. You walk over to a small plant. You tip the vial, allowing a drop of the poison to fall on one leaf. Almost instantly, the entire plant quivers, and all its leaves turn brown, shrivel, and fall off. You smile. The evil wizard thinks he is invulnerable behind all of his protective spells, but few spells can protect him from your handiwork...



This section of the rulebook describes the advanced careers a player may choose for their character. All of these groups of skills advance the three Basic Careers – fighters, mages and rogues.

None of these Skill Lists have a Skill Point cost associated with them and therefore do not have an on- or off-list cost. **All characters must be Level 5 to learn an Advanced Career skill.**

## Alchemist Advanced Career

Below is the list of skills available to players who wish to play an Alchemist. For a full description of the skill, see Chapter 5.

Alchemy Skill List					
Skill	Cost	Duration	Prerequisite Skill	Purchase	Tagged
Alchemy Lore	2	Constant	Literacy, Herbal Lore	Once	No
Potions I-V	2/2/3/4/5	Constant	Alchemy Lore	Multi	No
Poisons I-V	2/2/3/4/5	Constant	Alchemy Lore	Multi	No
Solutions I-V	2/2/3/4/5	Constant	Alchemy Lore	Multi	No
Create Golem I-VI	2/2/2/2/2/2	Constant	2 Rank 5 Alchemy Schools, Embalming	Multi	No
Dissection	5	Constant	Alchemy Lore	Once	No
Embalming	2	<i>Special</i>	Alchemy Lore, Dissection	Once	No
Identify Components	3	Constant	Alchemy Lore, Dissection	Once	No
Advanced Refining	5	Constant	Identify Component	Once	No
Make Contact	3	Constant	Any One Rank 3 Alchemy School	Once	No
Resist Alchemy	3	Instant	Alchemy Lore, Any Two Rank 3 Alchemy School	Multi	Yes
Poison Immunity	5	Constant	Resist Alchemy	Multi	No
Extend Duration	5	Constant	Alchemy Lore, Any Rank 4 Alchemy School	Once	No
Make Gaseous	3	Constant	Any Two Rank 4 of an Alchemy School	Once	No
Alchemical Focus	0	Constant	Alchemy Lore, Rank 3 of One School	Once	No
Inner Catalyst	0	Constant	Alchemy Lore, Rank 5 Potions	Once	No

### Special Notes for the Alchemy Skill List

- The Build costs separated by slashes are the costs for each rank in the school of Alchemy. For example, the list cost of the Potions School is given as 2/2/3/4/5; this means that the Rank 1 Potions School costs 2 Build, Rank 2 Potions School costs 2 Build, Rank 3 costs 3 Build, Rank 4 costs 4 Build and Rank 5 costs 5 Build.

## The Alchemist

An Alchemist is an individual devoted to understanding and unlocking the secrets of nature and using them to create rare and exotic substances. In addition to a devotion to studying all the available alchemical literature, the basis of the Alchemist consists of tradesman skills, such as refining, distilling, and preparing dissected parts into alchemical components. As the Alchemist advances they learn to combine these trades with their knowledge of the arcane and science to create standard alchemical items from known recipes. Once an Alchemist has advanced well into their career the famous alchemical skills become available, such as the creation of golems. At the apex of their career, after many years of hard work and study the alchemist may be able to achieve rank 5 of their chosen specialty and there by perform research and design their own alchemical items.

It is truly the rare and almost unheard of alchemist who has achieved rank 6 in any one school of alchemy.

## Alchemy Rules

Below are some special rules on the use and practice of Alchemy.

### Using Alchemical Items

Some alchemical items are easily used by anyone, while others require the wielder to be instructed. Any character can use any Potion, Solution, or Poison, so long as it is used in the correct manner.

If the character, for example drinks an *Oil of Sharpness* they would gain no benefit and would get an upset stomach instead; or if a character used a *Healing Potion* on a sword the potion would have no effect.

A character cannot be forced to drink an alchemical item if they are unwilling. They can be charmed or coerced into drinking something however. Characters who are Unconscious, Bleeding to Death, Mortally Wounded or Dying cannot drink alchemical items. Golems and non-corporeal undead cannot drink alchemical items either.

Although some alchemical items duplicate magical spell effects, these items are not magical themselves. Therefore, detection spells do

not detect alchemical items as magical.

Defenses that stop spells such as a *Defense*, *Negation*, *Reflection*, *Absorption*, and *Resist Suggestion* spells are ineffective against alchemical items. The *Purity* spell and Ritual of Alchemy Shield will stop most alchemy. These magical defenses and the Resist Alchemy and Nature's Purity skills will not stop alchemical items that produce an effect and therefore do not affect the character directly. The following alchemical items are stopped by magical defenses that stop physical attacks: *Paste of Binding*, *Acids*, *Fire Breath Potion*, *Sun Water*, *Paste of Stickiness*, and *Alchemical Lubricant*. Additionally, alchemical items like *Oil of Striking*, *Oil of Mithril Blade*, *Oil of Fire Blade*, and *Oil of Armor* affect the weapon or armor and are not stopped by these defenses. The *Purity* spell will not stop any ingested alchemical item. Gases and dusts are not stopped by defensive martial skills, if a character chooses to use one they take the affect of the alchemical item.

A *Purify Blood* spell cures or removes all alchemical effects that do not cause damage that





affect the character directly. For example, the effects of a *Sleep Poison*, *Paralysis Poison*, *Silence Poison*, *Giant Strength Potion*, etc. will end if the character is affected by a *Purify Blood* spell.

An alchemical item that is thrown like a dust, contact item or gas is used as soon as it is thrown, no matter where it lands or if a character catches the packet. **The player must tear about half the tag off the physical representation before throwing the item.** A character cannot “prepare” more than one alchemical item ahead of time before throwing them and the character has 1 minute to use the item before it becomes inert. Thrown contact poisons, in order to take affect, must hit a character with no physical Armor Points remaining. Alchemical items in a pouch or pocket are not broken if struck with a weapon. As a general rule, if you find any thrown alchemy on the ground during a big battle, you should assume it is used. This is also true for contact substances that are placed on a weapon or object. If the sword hits the player – not their weapon or shield – the alchemical item is used. If a defense that stops physical attacks is called against the alchemical item, the item is also used. Once any alchemy – thrown or applied – is used it cannot be reused or collected.

If a weapon or object coated with a poison is touched by bare skin, the poison is expended and the character is affected. If a character is immune to a poison, they cannot apply that poison to their bare hand. While they will not be affected by the poison, it is still expended.

It is possible to stack a spell and an alchemical item at the same time. As a rule, only one type of alchemical item can be drunk or used at one time. The same is true for alchemical items on objects. In other words, only one *Giant Strength* potion can be used at one time, or one *Oil of Striking*. You can use two oils on a weapon so long as they are of different types. If you do mix two like items, both will be destroyed.

*For example, Duncan uses an Oil of Striking +2 and an Oil of Silver Blade on his weapon. Now the weapon will swing for a base of 4 points of damage and with the “Silver” suffix, so “8 Silver” with all of his other bonuses. But if Duncan adds another Oil of Striking – of any strength – all oils of striking are destroyed or an Oil of Mithril Blade or Ghost Blade then all the blade oils are destroyed.*

Alchemical items on an item are used as soon as the item is used. If a person dies and must go to the Healers’ Guild, without their body, all alchemical effects are gone. If an item is shattered or destroyed, all

alchemical items on it are destroyed as well. All alchemical items take effect instantly after being administered, unless noted elsewhere.

### **Special Rule of Poisons**

A poison or other alchemical item that is an ingested substance can be placed in food or drink. Most of the food or drink must be consumed before the item will take effect, for marshaling purposes at least 75% of the food or drink counts as most.

If a character wants to poison a large container or vessel, such as a cask of ale or a pot of stew, they need to have enough doses of the alchemical substance to dose the entire batch or container.

*For example, Balthazar decides he wants to “spice” things up at the feast one night. He goes to a Marshal and asks how many servings of stew are in the pot in the kitchen. The Marshall rules that the pot holds 25 servings of stew. Balthazar would then need 25 Gypsy Love Poisons to dose the batch, any less and the attempt completely fails and all doses are lost. But Balthazar has been planning this for a long time and has the needed 25 doses of the poison. He sneaks in the kitchen and while Fugazi the Cook is not looking, dumps the poison into the pot, while the Marshal is watching. Now whenever someone finishes their stew they will fall in love with the next person of the opposite sex they see.*

Even though there is a potential for a lot of an alchemical item needed for a container, unless a character has the first rank of the appropriate school, the alchemical item is undetectable.

### **Material Components**

Alchemical items are produced by following a prescribed recipe. This involves physically and chemically transforming the material components into the desired product by sheer force of will. There are two types of components: common ones, called Reagents, and Rare Components. Reagents are simple, common chemicals and herbs that are used in brewing the item. They are found all over Midlantia: from the Elven forest to the Dwarven mines, from the ocean to the Northern Ice. None of these are difficult to get, nor do they require special skills to collect, but require some one willing to get them, like merchants. The Reagents can be purchased, typically for 5 copper pieces each, from the Alchemist Guild, found while adventuring, or at the Merchants Guild. The second component type, the Rare Component, must be acquired in game.

In order to properly collect material components, the player must have Dissection for characters, Herbal Lore for plants, and anyone can collect minerals once identified. When gathering material components, a player should write down the nature of the component and have an appropriate witness sign their name and player number. It should then be taken to an Alchemy Marshal or the Treasure Marshal, where a tag will be generated. In game, the Alchemist actually sits down after dissecting and refines, to a certain degree, the component to get from it all he needs to make it useful. For example the Alchemist needs the blood of a Troll. All the blood in the Troll is bled out and the final drops are collected and brought back to the guild. There the Alchemist refines it down to a few useful doses. A player can increase the usefulness of these Rare Components with the Advanced Refining skill.

A character may never substitute one component for another. If the recipe calls for the Willing Blood of a Paladin, only the Willing

Blood of a Paladin may be used. Even if that blood comes from a human, a Solar or a Dragon, it is the same component. If a character wishes to use a different component in a recipe, they must research a new version of that alchemical item. Players should read the section on creating new alchemy for further information.

Some characters, especially monster types, might be worth more doses of a component being dissected. For example, the character is looking for Essence of a Memory Moss and discovers a creature called the Mother of all Memory Mosses. Instead of the two doses the character would normally get, they will receive four doses from dissecting the character. The Plot Committee will indicate on any special character if they yield more than the normal number of doses, the player does not need to ask. If the NPC's card does not say it gives more doses, then it does not.

### Alchemical Tags

Alchemical items can only be identified by characters with the appropriate Alchemy skill. Therefore, a character who acquires alchemical items will not know what the item is until it is properly identified. This does not preclude anyone from labeling the item in-game either correctly or incorrectly but the number, and/or description on the LAIRE item tag must be present, correct and whole. An out-of-game tag will be placed on the physical representation for each item. This tag should have the code number for the item; this allows characters with the appropriate skills to identify the item. The character identifying an item should initial the out-of-game tag as proof of a character's in-game knowledge of the item's identity with their initials and player number.

**All finished products must be in a vial.** A player cannot have their character carry a stack of finished items while they adventure. It is acceptable to have just tags and no vials when a character has their items in its place of storage.

*For example, Pyrrhus has several poisons and potions in his in-game box in his room at the event. He keeps them on a tag ring, not in vials. He decides he wants to sell some about town and use a few others on an adventure. He must place all the tags he is taking from his room into vials; he cannot simply take the tags and carry them on his tag ring.*

### Recipe Books

Every alchemist is required to have a recipe book. The alchemist must produce the recipe to the marshal when he makes his alchemical item, including golems. A recipe can be copied as any other text, but must be done in-game. Each recipe must appear on its own piece of paper. This information must appear on the page:

- School of Alchemy the item belongs to
- Name of item
- Rank
- Rare component(s)
- Description of the item
- The marshal's initials and date

The player may feel free to add other information to the page, such as directions for brewing the potion, but the basic information must be present.

If the recipe is copied from someone or somewhere, the marshal needs to see the original source and sign and date the new copy. There is effectively no limit to the number of copies an alchemist can have.

### Producing Alchemical Items

All alchemical items must be produced in-game with a marshal present. The player must produce the Reagent Tags, the Rare Component Tags and their copy of the Alchemical Recipe before they begin to brew. The character is limited to the amount of

Alchemy Production and Cost Table						
	Production Time (Min)	Production Point Cost	Number of Reagent Tags			Production Points for a Rank
			In Guild	Portable Lab	On the Road	
Rank 2	5	2	2	4	8	10
Rank 3	10	4	4	8	16	15
Rank 4	20	6	8	16	32	20
Rank 5	30	8	16	32	64	25
Rank 6	40	10	32	64	128	35
Rank 7	50	12	64	128	n/a	40
Rank 8	60	14	128	n/a	n/a	45
Rank 9	70	16	256	n/a	n/a	50
Rank 10	80	18	512	n/a	n/a	55

alchemy they can create in one month's time. The rate of production, in-game production time, and cost is given in the table below.

An Alchemist receives 5 Production Points per Rank of skill that they know, per school that they know. So a character with Rank 2 Potions will have 10 Production Points for potion creation only and a character with Rank 5 Solutions would have 25 Production Points of solution creation only. The Alchemist gets to renew their Production Points on the first day of the month, regardless of when the LAIRE Event takes place. The character gets their production for each school of Alchemy they know. However, the earned Production Points for each school are not transferable between schools; a player cannot use their Poison Production Points to make Solutions. The points may only be combined when making a Golem. Each alchemical item must be made separately and cannot be created in "batches". The alchemist does not have to work on their items consecutively, but must complete the item once started. Brewing alchemical items does not require the characters complete concentration. Therefore, they are able to converse, cast spells, etc, however if they are attacked or forced to walk away from their work their brewing automatically fails and all Reagents and Rare Components are lost.

*For example, Terrance with Rank II Solutions, Rank IV Poisons and Rank V Potions has 10 Production Points towards Solutions, 20 Production Points towards Poisons and 25 Production Points towards Potions. He cannot use his Potion Production Points to make a Solution or Poison.*

A character with the Alchemy Skills must turn in the Rare Component tags and the necessary number of Reagent tags at the beginning of the production to the Alchemy Marshal. The marshal will note on the player's Character Card the number of Production Points for each school they have expended.



There is a chance of failure when making alchemical items. If a character rolls a Failure or a Critical Failure, the major component and all reagents are expended. The chance to fail to make an alchemical item is:

- An Alchemist making an alchemical item at the rank they know has a 15% chance of Failure. When creating items below their rank, the Alchemist gains +5% to their roll per rank. See table below.
- An Alchemist making an alchemical item at the rank they know has a 3% chance of Critical Failure. When creating items below their rank, the chance is reduced by 1%. See table below.
- A roll of 100 always fails.

Failure/ Crit Fail		Rank of Alchemy School Known				
		2	3	4	5	6
Rank of Item Being Created	2	15%/3%	10%/2%	5%/1%	1%/0%	1%/0%
	3	-	15%/3%	10%/2%	5%/1%	1%/0%
	4	-	-	15%/3%	10%/2%	5%/1%
	5	-	-	-	15%/3%	10%/2%
	6	-	-	-	-	15%/03

- +5% bonus for doubling the Production Time.
- +5% bonus for using double the number of base reagents.

For example, Terrence from the example above wants to use his Production Points and alchemy skills to make some alchemical items. First, he finds an Alchemy Marshal. Then together they go to the Alchemist's Guild to brew up his concoctions. First he decides to make three 8 Point Sun Water solutions. He takes three doses of Blood of a Willing Healer, and six reagent tags (2 reagents x 3 solutions). Each solution takes 5 minutes to make. The marshal times each solution and, at the end of each, he asks Terrence to roll percentile dice. Terrence rolls a 37, 24, and a 94. Terrence successfully creates two solutions, and fails at one. The marshal writes out two tags for the successful creations.

Next, Terrence wants to create two gaseous Silence poisons. He takes out two doses of Tongue of a Halfling. Each poison takes 5 minutes, 4 Production Points (2 Production Points x 100%), and 4 reagent tags (2 reagent tags x 100%). A total of 10 minutes, 8 Production Points, and 8 Reagent tags. After each poison is completed the marshal has Terrence roll and he gets a 12 and a 100. The first poison is created successfully, but the last is a flaw. The marshal informs Terrence he takes 4 points of damage. The marshal fills out the tag for the successful creation.

Lastly, Terrence wants to make a contact Heal Mind potion and a Strength Potion +3 with an extended duration of 10 minutes. Terrence takes

out his Darkwood Mushroom and Muscles of a Troll component tags. Also, he counts out 12 reagent tags for the former (8 reagent tags x 50%) and 6 reagent tags for the latter (4 reagent tags x 50%). The potions Terrence wishes to make will cost 9 and 6 Production Points respectively. Once again the marshal times the creation of the potions, 20 minutes for the first and 10 minutes for the second. Terrence rolls a 45 and a 26. The marshal fills out two tags for Terrence and tares up the used component and reagent tags.

Now Terrence takes his new alchemy and heads out, ready for an adventure. He still has 4 Solution, 12 Poison, and 10 Potion Production Points left he can use later.

### Modifying Alchemical Items

There are three skills a player can have their Alchemist character learn and use to modify the basic alchemical recipes found later in this section. The first is Extend Duration, which increases the duration of some alchemical items. The most a character can increase the duration is two steps down on the following chart. Each level has its own associated cost. The following table outlines the duration times and what it takes to use this skill.

Time Increments	Extend Duration Table		
		Production Point Increase	Reagent Tag Increase
Instant			
10 Min	+1 Level	+50%	+50%
1 Hour	+2 Levels	+100%	+100%
6 Hours			
24 Hours			
1 Event			

Note: "Level" refers to how many time increment increases you make. Going from 10 Min to 1 Hour is +1 Level; going to 6 Hours is +2 Levels.

No alchemical item can have a duration longer than 1 Event.

The second and third skills the character can use to modify their alchemical items are Make Contact and Make Gaseous. These are two separate skills and are mutually exclusive; the player must choose one or the other when producing their items. Make Contact skill allows the alchemical item to be delivered by touch: a thrown item, placed on an object, or applied to a blade. Make Gaseous skill makes the alchemical item affect everyone in a radius indoors or outdoors. To determine who is affected, the character struck with the gas or the closest player to the gas should stretch their arms out to either side and turn in a circle and anyone in that radius that the player can touch is affected. In the below table, the cost and Production Point increase for using these skills are outlined.

Contact and Gaseous Table			
	Production Point Increase	Reagent Tag Increase	Additional Component
Contact	+50%	+50%	Pitchblende
Gaseous	+100%	+100%	1 pt. of Acid

For purposes of making gases, any level acid will do and the character can use only one point of it. The Alchemy Marshal will mark off the point on the tag.

All Production Point and Reagent Tag increases are cumulative. So if an Alchemist wanted to make a gaseous 6 hour Heroism potion it

would cost them 24 Production Points (8 Base + 8 for Extend Duration + 8 for Make Gaseous), 48 Reagent Tags (16 Base + 16 for Extend Duration + 16 for Make Gaseous), and 30 minutes in-game.

No item once made can be changed. **Therefore Extend Duration, Make Contact and Make Gaseous must be used at the time of creation and cannot be used on an already existing item.** For a full description of Extend Duration, Make Contact and Make Gaseous skills see Chapter 5.

### Creating a Golem

The pinnacle of alchemical mastery is the art of golem crafting. By means of the Create Golem skill, the character is able to animate a golem to serve his needs. The golem has no free will and will obey the commands given to it to the fullest extent of its ability. While the golem is robotic in nature, it does understand the intent of the commands given to it, understanding the will of the creator. It is able to remember any number of commands.

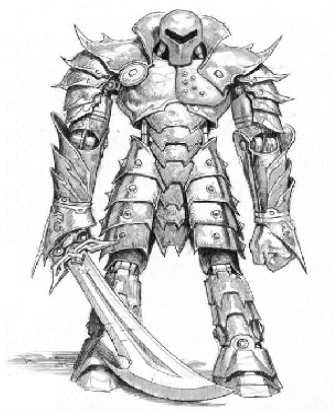

The golem however is unable to make rational choices. If the golem is ordered to: “Kill anyone who attacks me,” the golem will attack a person who gives a friendly slap. The golem cannot be ordered to “Attack anyone who steals something from this room,” but can be ordered to “Attack anyone who takes anything from this room they did not come in with.” In the latter case the golem will attack a character even if the alchemist gives them something to take with them.

The golem can never be made to harm the creator, and similarly the creator cannot order the golem to strike them self. The golem can be ordered to listen to the commands of someone else, but the creator’s command will always override anyone else they have given control

fashion the golem. The alchemist needs to find someone with Rank 2 of either the Weapon Smith or Armor Smith skill to create the husk needed to animate the golem.

The creation process ends with the alchemist transfusing all of their blood to the golem thereby delivering a Killing Blow to the character. The alchemist may be healed appropriately. The character will lose a number of Body Points equivalent to the level of golem created until the golem is destroyed. The Body Points must come from the creator and not a potion or spell. This creates the link between creator and golem. The golem must be created in the Alchemist Guild or an equivalently outfitted laboratory.

Should the golem be destroyed, the creator will know it instantly (or as soon as a marshal can tell the player) and will experience pain as the Body Points return.

A character who has a golem must find a volunteer to play the golem. Any player can volunteer their own time to play the golem, but they cannot make it part of their NPC duty without a Plot Marshal’s approval. However, if a Marshal has foreknowledge that a golem is present in someone’s room and they send out a group to specifically engage that area, they should send an extra NPC to play the golem.

### Creating New Alchemical Items

Once a character learns Rank 5 in a school of Alchemy, they are able to perform research to create new alchemical items. There are some guidelines that the player should follow and think about when proposing a new item.

- Items that heal or cure cannot be made gaseous. The basic premise or in-game justification for this is the process of making an item gaseous – namely adding acid in the final steps – destroys the item or adds too many impurities to the item for it to work.
- There are no “Purify Blood” potions. The only items that do something similar to this are the antidote poisons.
- Alchemical items do not affect magic directly. While there are potions that make you indirectly immune to a magical effect, generally speaking, items that destroy or dispel

Golem Creation Table						
	Golem	Creation Time	Production Points	Reagent Tags*	Major Component	Minor Component**
Rank 1	Wood	30 min	40	100	Knot of Wood from Mistwood Tree	Carved Wood Statue Made from Material Worth 5 silver pieces
Rank 2	Flesh	45 min	50	200	Copper Heart (25cp) and 400 points of Lightning Damage	Embalmed Parts from 4 Creatures
Rank 3	Stone	60 min	60	300	Stone from the Heart of a Bed of Lava	Carved Stone Statue Made from Material Worth 1 gold piece.
Rank 4	Iron	90 min	70	400	Essence of a Level 5 Fire Elemental	Forged Iron Statue Made from Material Worth 2 gold pieces
Rank 5	Steel	105 min	80	500	Saliva of a Red Drake	Forged Steel Statue Made from Material Worth 3 gold pieces
Rank 6	Mithril	120 min	90	600	Fire Ruby	Forged Mithril Statue Made from Material Worth 100 gold pieces

\*\* Two whole, un-dissected, destroyed golems of the same type can be substituted for the minor component.

of the golem to.

The character must gather the needed components to create the golem before starting to animate the golem. In the case of flesh golems, the alchemist has the required skill to sew the golem together. Wood and stone golems require someone with the appropriate craftsman skill to

magic; drain or add Power Points; stop spells; or duplicate special magical effects like Total Power or sorcery rituals are not viable alchemical items.

- The Rare Component should reflect or symbolize the desired alchemical effect. Lizardman scales would be a poor choice for a potion of Fire Breathing.
- As a general rule, each item only has one Rare Component. There are some instances where an item has two Rare Components, as in the case of *Dust of Sleep*, but the player should limit themselves to one basic Rare Component.
- An item that gives the character more uses or effects from another item is also disallowed. No wishing for more wishes.

There are other considerations, such as game balance, that will take into account when approving the new item.

**Any alchemical item not found in these rules must have a simple description of the effect on the back of the item tag.**

The player is required to make their proposal in writing. This proposal must include:

- The desired effect of the alchemical item.
- The desired duration of the effect (instant, 10 minutes, 1 hour, etc.)
- The Rare Component needed.
- The proposed school and rank.

After approval, the chance of initial success is 50% after fulfilling these base requirements:

- 1 silver piece times the rank of the alchemical item.
- The number of doses of Reagents the alchemical item requires.
- 10 minutes per rank of in-game roleplaying; then an additional month of out-of-game research for modifying an existing recipe or two months of out-of-game research to create a new recipe.
- A single dose of the Rare Component.

To increase this success chance, the character may spend more time and money:

- +5% per extra Event of roleplaying up to a maximum of four extra Events.
- +1% per extra 1 silver piece spent but the maximum chance is 95%.
- +25% bonus for modifying an existing recipe.
- +1% times (Character's Rank of Alchemy School – Rank of Alchemical Item being Researched)
- Special bonuses assigned by the Plot Committee, which could be either a positive or a negative bonus.

The maximum chance of success is always 95%.

After submitting the proposal, the player will be informed if the alchemical item will not be allowed in-game or if the character will never be able to make the item. If approved, the character then spends the required time and rolls to determine the success of the research and tries to create the item. If they succeed their research roll but some aspect of the recipe is inappropriate – wrong Rare Component, wrong effect etc – the E-Board will inform the player after they attempt to create their new alchemical item. If they fail the research roll, the player will be informed after they failed to create the new alchemical item that the roll failed and they should try again after researching at least another Event gaining the appropriate bonus, however the character needs not spend more money.

## Alchemical Item Lists

Below are the commonly available items players can find in-game. Players are able to make new items, therefore you should not be surprised to find new things as you play the game.

### Description Headings

Each alchemical item has a description heading that summarizes some of the important information pertaining to each item. Below is an explanation of what each heading indicates.

### Forms

There are three forms each alchemical item can take: Ingested, Contact, and Gaseous. Ingested indicates that the substance must be consumed to work. Alchemical items, like Poisons, can be placed into a drink or on food and still function normally. Contact indicates that the Make Contact skill can be used on the item to make it able to be applied to a weapon or object and will take effect if touched. Gaseous indicates that the substance can be turned into a gas with the Make Gaseous skill. Some alchemical items have a *Special* application method. The player should read the descriptive text to learn more.

### Duration

Every alchemical item has a duration. These include Instant, 10 Minutes, 1 Hour, 6 Hours, 24 Hours, or 1 Event.

### Component

This is the Rare Component needed to make this item.

Some components have a descriptor in parentheses juxtaposed to the components name that indicates the amount of that substance that constitutes a dose – the amount of that substance that is needed to make that alchemical item.

### Yield

Some Rare Components come from characters. When a player dissects a character, this heading indicates how many usable doses they can get from that character. For a full description on how the Dissection skill works, see the Dissection skill description in Chapter 5.

### Rarity

This heading indicates how rare the component is. Advanced Refining skill takes longer on more rare components. This also gives the player a relative idea of how much the component is worth.





## Poisons School

Poison school represents those alchemical items that are designed to harm or incapacitate a character directly.

### 2<sup>nd</sup> Rank Poisons

**6 Point Poison** **Forms:** Ingested, Contact,  
**Duration:** Instant Gaseous

This poison delivers 6 points of direct body damage.

Extend Duration has no effect on this poison. This recipe will produce 2 alchemical items when made.

**Love Poison** **Forms:** Ingested, Contact,  
**Duration:** 10 Minutes Gaseous

When this poison affects a character, they fall in love with the first member of the opposite sex they see. A *Purify Blood* spell will remove the effect before the duration expires.

**Slow Death** **Forms:** Ingested, Contact,  
**Duration:** Instant Gaseous

This poison will bring the affected character to the Brink of Death after 6 hours, and can be healed normally. A *Purify Blood* is not needed before the character is lified; the poison has run its course. After being poisoned, the character begins to feel ill – stomach pains, headache, weakness and a fever – and these symptoms get worse over the 6 hours. If the character is sleeping when affected by this poison, they will wake up after an hour of being affected.

Extend Duration has no effect on this poison. This recipe will produce 2 alchemical items when made.

**Silence Poison** **Forms:** Ingested, Contact,  
**Duration:** 10 Minutes Gaseous

The character affected by this potion is unable to speak and therefore unable to cast spells or use any other skill that requires a verbal. The character is still able to call damage and invoke latent spells, as these actions are out-of-game. The effect can be cured by a *Purify Blood* spell.

### 3<sup>rd</sup> Rank Poisons

**12 Point Poison** **Forms:** Ingested, Contact,  
**Duration:** Instant Gaseous

This poison delivers 12 points of direct body damage.

Extend Duration has no effect on this poison. This recipe will produce 2 alchemical items when made.

**Blindness Poison** **Forms:** Ingested, Contact,  
**Duration:** 10 Minutes Gaseous

This poison causes the target character to be blind. They will remain blind for 10 minutes or until a *Purify Blood* spell is used to cure the poison. While blinded a character cannot make any melee attacks unless they have the Blind Fighting skill. They can close their eyes and throw a spell “blind”. They can use their weapons to attempt to block attacks directed at them, so long as their eyes are closed and do not attempt to swing their weapon. They are able to use any defensive skills or spell defenses they have, such as Master Parry, Crit Parry, or *Negation*.

When you roleplay the effects of a *Blind Poison*, you can close your eyes. However, take care if you are on rough terrain or in a room

with sharp furniture. It is better to keep your eyes open and be safe than it is to role-play your character’s blindness convincingly.

**Paranoia Poison** **Forms:** Ingested, Contact,  
**Duration:** 10 Minutes Gaseous

The target character becomes paranoid that everyone and everything is out to get them. A *Purify Blood* spell will end the effect before the duration expires.

**Quick Death Poison** **Forms:** Ingested, Contact,  
**Duration:** Instant Gaseous

This poison will bring the affected character to the Brink of Death after 1 hour. They require the normal healing methods for healing a character at the Brink of Death. A *Purify Blood* is not needed before the character is lified; the poison has run its course. After being poisoned, the character begins to feel ill – stomach pains, headache, weakness and a fever – and these symptoms get worse over the hour. If the character is sleeping when affected by this poison, they will wake up after 10 minutes of being affected.

Extend Duration has no effect on this poison.

**Rank 3 Antidote** **Forms:** Ingested, Contact,  
**Duration:** Instant Gaseous

This antidote will relieve all the effects of any Rank 3 or lower poison and any other toxins or natural poisons that mimic a poison in the poison school.

Extend Duration has no effect on this poison. This recipe will produce 2 alchemical items when made.

**Weaken Poison Poison** **Forms:** Ingested, Contact,  
**Duration:** 10 Minutes Gaseous

This poison causes the target character to deal no more than 1 point of damage with all martial attacks regardless of their Damage Bonus or Strength Bonus and lose all Strength Bonuses for the duration of this poison.. This poison does not affect special weapon attacks like the Slay skill, Assassinate skill, Stun skill, etc. For skills that modify damage, the base weapon damage is always 1. For example, if a weakened character uses a Critical Attack skill, they will deal 2 points of damage. Similarly, a weakened character will only Waylay dealing 1 point of damage.

This recipe will produce 2 alchemical items when made.

### 4<sup>th</sup> Rank Poisons

**18 Point Poison** **Forms:** Ingested, Contact,  
**Duration:** Instant Gaseous

This poison delivers 18 points of direct body damage.

Extend Duration has no effect on this poison. This recipe will produce 2 alchemical items when made.

**Amnesia Poison** **Forms:** Ingested, Contact,  
**Duration:** *Special* Gaseous

When the target character is affected by this poison, they will forget everything 10 minutes prior to the poisoning. If a *Purify Blood* is used within 6 hours of taking the poison, the poison is cured. If Extend Duration is used during creation, then the length of time forgotten is extended; therefore, the Amnesia poison can be made to cause the target to forget everything 1 hour and 6 hours back.

The Poison will last for three months, including the month it was taken. This is not three Events, so even if the player does not play that character, the time will expire in three months. So, if a character takes the poison in January, it will end at the end of the March Event.

**Feeblemind Poison**                      **Forms:** Ingested, Contact,  
**Duration:** 10 Minutes                      Gaseous

This poison reduces the target character to a blithering idiot, unable to use any skills, call latent spells, or defend themselves. This effect can be removed with a *Purify Blood* spell.

**Paralysis Poison**                      **Forms:** Ingested, Contact,  
**Duration:** 10 Minutes                      Gaseous

This poison completely paralyzes the target character; they cannot move or speak. The only acts a paralyzed character can perform are to move their eyes, blink, or invoke a latent spell. A Killing Blow may be delivered while a character is paralyzed.

Paralyzed characters can be moved as they are not attached to the ground; in addition, their limbs can be moved by some external force such as another player. The target will still be unable to move from their new position.

**Rank 4 Antidote Poison**                      **Forms:** Ingested, Contact,  
**Duration:** Instant                      Gaseous

This antidote will relieve all the effects of any Rank 4 or lower poison and any other toxins or natural poisons that mimic a poison in the poison school.

Extend Duration has no effect on this poison. This recipe will produce 2 alchemical items when made.

**Sleep Poison**                      **Forms:** Ingested, Contact,  
**Duration:** 10 Minutes                      Gaseous

This Poison causes a character to sleep for 10 minutes. Unlike the *Sleep* spell, one point of damage will not awaken the character; rather the character needs to receive the appropriate antidote or a *Purify Blood* spell.

## 5<sup>th</sup> Rank Poisons

**24 Point Poison**                      **Forms:** Ingested, Contact,  
**Duration:** Instant                      Gaseous

This poison delivers 24 points of direct body damage.

Extend Duration has no effect on this poison.

This recipe will produce 2 alchemical items when made.

**Forget and Remember Poison**                      **Forms:** Ingested, Contact,  
**Duration:** Special                      Gaseous

A character affected by this poison will forget one selected incident, as told by the first person the character comes in contact with, and will remember what is prompted with false memory. If a *Purify Blood* is used within 6 hours of taking the poison, the poison is cured.

The Forget and Remember Poison will last for three months, including the month it was taken. This is not three Events, so even if the player does not play that character, the time will expire in three months. So, if a character takes the poison in January, it will end at the end of the March Event.

When the poison ends, whatever the means, the character will remember both the true memory and the false ones and will know the difference.

A character cannot be made to forget skills, but they can be made to forget they have those skills. This poison cannot be self induced. The next character who issues the commands to “Forget” and “Remember” are obeyed.

Extend Duration has no effect on this poison.

**Instant Death Poison**                      **Forms:** Ingested, Contact,  
**Duration:** Instant                      Gaseous

This poison will bring the affected character to the Brink of Death instantly. They require the normal healing methods for healing a character at the Brink of Death. A *Purify Blood* is not needed before the character is Lived; the poison has run its course.

Extend Duration has no effect on this poison.

**Rank 5 Antidote**                      **Forms:** Ingested, Contact,  
**Duration:** Instant                      Gaseous

This antidote will relieve all the effects of any Rank 5 or lower poison and any other toxins or natural poisons that mimic a poison in the poison school.

Extend Duration has no effect on this poison. This recipe will produce 2 alchemical items when made.

## 6<sup>th</sup> Rank Poisons

**30 Point Poison**                      **Forms:** Ingested, Contact,  
**Duration:** Instant                      Gaseous

This poison delivers 30 points of direct body damage.

Extend Duration has no effect on this poison.

**Rank 6 Antidote**                      **Forms:** Ingested, Contact,  
**Duration:** Instant                      Gaseous

This antidote will relieve all the effects of any Rank 6 or lower poison and any other toxins or natural poisons that mimic a poison in the poison school.

Extend Duration has no effect on this poison.

**Sleeping Beauty Poison**                      **Forms:** Ingested, Contact,  
**Duration:** Instant                      Gaseous

A character affected by this poison will fall into a catatonic sleep. While under the effects of this poison, the character no longer needs nourishment, air, and stops aging. The character is not immune or protected from attacks and is affected normally, even from other alchemical items.

This poison is cured by a *Rank 7 Antidote*, Unicorn Pool Water or a Ritual of Absolute Healing only; a *Purify Blood* spell or similar affect will not awaken the character.

At the time of creation, a condition that will awaken the character must be chosen. Identifying the poison will not reveal the condition only what type of poison it is. This condition must be approved by the Head of Plot. The condition must be general enough to be possible and cannot be so specific as to be impossible or improbable to discover. Examples of acceptable conditions are: A kiss from a Royal Noble (kings, queens, dukes etc.), the touch of a rose, the tear of a child, etc. Unacceptable conditions are: a slap from Bob, the left toe nail of George the monkey, the target’s own voice, etc.

Extend Duration has no effect on this poison.

## Potions School

This school of alchemy is comprised of items that heal or augment a character. These items are highly sought after by fighters and other characters to increase their fighting prowess.

A special note to the potions school, potions that heal some ailment can be made into a contact substance, but **cannot** be applied to a weapon and delivered as damage.

### 2<sup>nd</sup> Rank Potions

**Hang-over Cure** **Forms:** Ingested, Contact  
**Duration:** Instant

When used, this potion will cure a hangover.

Extend Duration has no effect on this potion. This recipe will produce 3 alchemical items when made.

**6 Point Healing Potion** **Forms:** Ingested, Contact  
**Duration:** Instant

This potion heals 6 Body Points when used.

Extend Duration has no effect on this potion. This recipe will produce 2 alchemical items when made.

**Restore Sight Eye Drops** **Forms:** *Special*  
**Duration:** Instant

This potion will cure blindness, but will not re-grow eyes. This potion cannot be made into a contact or gas version. It must be applied to the eyes and is inherently a contact item.

Extend Duration has no effect on this potion. This recipe will produce 2 alchemical items when made.

**Super Alcohol x3** **Forms:** *Special*  
**Duration:** Permanent

This potion permanently triples the potency of an alcoholic drink. Imbibing this potion directly has no effect; it must be used on an existing alcoholic beverage. This potion cannot be made into a contact or gas version.

Extend Duration has no effect on this potion.

**Truth Serum 1** **Forms:** Ingested, Contact  
**Duration:** 1 Question, 10 Minutes

This potion forces the character to immediately answer the next question directed at the character directly and truthfully with up to a 10 minute answer.

Extend Duration has no effect on this potion.

### 3<sup>rd</sup> Rank Potions

**12 Point Healing Potion** **Forms:** Ingested, Contact  
**Duration:** Instant

This potion heals 12 Body Points when used.

Extend Duration has no effect on this potion. This recipe will produce 2 alchemical items when made.

**Cure Disease Potion** **Forms:** Ingested, Contact  
**Duration:** Instant

This potion will remove all diseases affecting the target. Some diseases may be resistant to the effects of this potion and stronger more specific cures must be found.

Extend Duration has no effect on this potion. This recipe will produce 2 alchemical items when made.

**Endure Condition** **Forms:** Ingested, Contact  
**Duration:** 10 Minutes

This potion halves the effects of one condition for the duration of the potion. The conditions that the alchemist can create potions for are fire, water, air, earth, life, death or alchemy (poison, solutions and potions), and in the case of alchemy, it does not affect external damaging alchemy such as acids and pastes. The desired condition must be specified at time of creation and recorded on the item tag.

In the case of damaging elemental or alchemical effects, the damage is halved. If the effect has a continuing effect, such as an *Enfeeblement* spell, the duration is halved. For spells which do not affect the character directly, such as *Wall of Force*, there is no effect.

This potion does not work against Eldritch attacks. This recipe will produce 2 alchemical items when made.

**Heroism Potion** **Forms:** Ingested, Contact  
**Duration:** 10 Minutes

This potion will make the character immune to all fear affects for the duration of the potion.

**Resist Suggestion** **Forms:** Ingested, Contact  
**Duration:** 10 Minutes

The character under the effects of this potion avoids the affects of the next *Truth* spell or serum. While the latent nature of this potion lasts for the duration of this potion, it can only stop one *Truth* spell. If a Truth Serum is used, the entire serum is negated. For example, if a Truth Serum 6 is applied to a character, then all six questions are negated. A subsequent use of another Truth Serum will have normal effects.

**See Magic Eye Drops** **Forms:** *Special*  
**Duration:** Instant

The character using this potion can see magic (as the spell) for the duration of this potion. This potion cannot be made into a contact or gas version. It must be applied to the eyes and is inherently a contact item.

This potion will only work if there is a Marshal present.

**Stamina Potion +6** **Forms:** Ingested, Contact  
**Duration:** 10 Minutes

Using this potion adds +6 Body Points that can be healed.

**Strength Potion +3** **Forms:** Ingested, Contact  
**Duration:** Instant

This potion grants the user a +3 Strength Bonus, Non-Combinable which allows one feat of great strength or +3 points of damage for the duration of the potion.

**Super Alcohol x6** **Forms:** *Special*  
**Duration:** Permanent

This potion permanently increases the potency of an alcoholic drink six fold. Imbibing this potion directly has no effect; it must be used on an existing alcoholic beverage. This potion cannot be made into a contact or gas version.

Extend Duration has no effect on this potion.

**Truth Serum 3** **Forms:** Ingested, Contact  
**Duration:** 3 Questions, 10 Minutes

This forces the target to immediately answer the next three questions directed at the character directly and truthfully with up to a 10 minutes in answer for each question.

Extend Duration has no effect on this potion.



**4<sup>th</sup> Rank Potions**

**18 Point Healing Potion**      **Forms:** Ingested, Contact  
**Duration:** Instant

This potion heals 18 Body Points when used.

Extend Duration has no effect on this potion.

This recipe will produce 2 alchemical items when made.

**Bainite Cure**      **Forms:** Ingested, Contact  
**Duration:** Instant

This potion will cure a character who has been turned into a Bainite brining them to the Brink of Death. If the character has not completely turned into a Bainite, they will simply be cured with no other ill effects. This potion has no effect on True Bainites.

Extend Duration has no effect on this potion.

**Fire Potion 16 pts**      **Forms:** Ingested  
**Duration:** *Special*

The character using this potion can breathe fire three times for 16 points of fire damage each time. The three attacks must be used within 1 hour, or the character takes the damage of the remaining charges of the potion.

Extend Duration has no effect on this potion. This recipe will produce 2 alchemical items when made.

**Heal Mind Potion**      **Forms:** Ingested, Contact  
**Duration:** Instant

This potion will undo the effects of an *Enfeeble* spell. It may also cure insanity, amnesia, and possession (a Plot Marshal must determine whether the *Heal Mind* is successful). All mind effects are cured by application of this potion.

Extend Duration has no effect on this potion. This recipe will produce 2 alchemical items when made.

**Stamina Potion +12**      **Forms:** Ingested, Contact  
**Duration:** 10 Minutes

Using this potion adds +12 Body Points that can be healed.

**Strength Potion +6**      **Forms:** Ingested, Contact  
**Duration:** Instant

This potion grants the user a +6 Strength Bonus, Non-Combinable which allows one feat of great strength or +6 points of damage for the duration of the potion.

**Super Alcohol x9**      **Forms:** *Special*  
**Duration:** Permanent

This potion permanently increases the potency of an alcoholic drink six fold. Imbibing this potion directly has no effect; it must be used on an existing alcoholic beverage. This potion cannot be made into a contact or gas version.

Extend Duration has no effect on this potion.

**Truth Serum 6**      **Forms:** Ingested, Contact  
**Duration:** 6 Questions, 10 Minutes

This forces the target to immediately answer the next six questions directly and truthfully with up to a 10 minutes in answer for each question.

Extend Duration has no effect on this potion.

**5<sup>th</sup> Rank Potions**

**24 Point Healing Potion**      **Forms:** Ingested, Contact  
**Duration:** Instant

This potion heals 24 Body Points when used.

Extend Duration has no effect on this potion. This recipe will produce 2 alchemical items when made.

**Fire Potion 32 pts**      **Forms:** Ingested  
**Duration:** *Special*

The character using this potion can breathe fire three times for 32 points of fire damage each time. The three attacks must be used within one hour or the character takes the damage of the remaining charges of the potion.

Extend Duration has no effect on this potion.

**Restore Limb Potion**      **Forms:** Ingested, Contact  
**Duration:** Instant, *Special*

This potion will instantly mend all broken limbs. In addition, any severed limb can be re-grown in 10 minutes.

This potion can also re-grow a severed head, but the use of this potion in this manner requires one use of the Battle Surgery skill and will only re-grow the head, not any other limbs. This process takes 10 minutes.

This recipe will produce 2 alchemical items when made.

**Resist Condition**      **Forms:** Ingested, Contact  
**Duration:** 10 Minutes

This potion renders the character immune to the effects of one condition for the duration of the potion. These are: fire, water, air, earth, life, death, or alchemical items and effects and in the case of alchemy, this potion has no affect on external damaging alchemy such as acids and pastes. The desired condition must be specified at time of creation and recorded on the item tag.

The elements you can resist and what the component is, are given in the table below.

Condition to Resist	Component
Fire	Essence of a Fire Elemental
Water	Essence of a Water Elemental
Air	Essence of a Air Elemental
Earth*	Essence of a Earth Elemental
Life	Essence of a Life Elemental
Death	Essence of a Death Elemental
Alchemy	Scaven Stone

\*Resist Condition: Earth makes the character immune to the Bonds School spells and elemental Earth damage attacks and effects, not to physical damage.

This potion will protect the character from spells, effects, magical attacks, and specialty attacks for that element.

A Scaven Stone has 1 Dose for every 25 Power Points in the stone, rounded down.

**Resist Necromancy**      **Forms:** Ingested, Contact  
**Duration:** 10 Minutes

This potion renders the character immune to the effects of necromancy for the duration of the potion rendering the character immune to the Necromancy School, being turned in to an undead, spell and effects.

This potion is not stackable with the *Resist Condition* potion.

**Stamina Potion +18** Forms: Ingested, Contact

**Duration:** 10 Minutes

Using this potion adds +18 Body Points that can be healed.

**Strength Potion +9** Forms: Ingested, Contact

**Duration:** Instant

This potion grants the user a +9 Strength Bonus, Non-Combinable which allows one feat of great strength or +9 points of damage for the duration of the potion.

## 6<sup>th</sup> Rank Potions

**20 Point Healing Potion** Forms: Ingested, Contact

**Duration:** Instant

This potion heals 20 Body Points when used.

Extend Duration has no effect on this potion.

**Alchemical Life** Forms: Contact

**Duration:** Instant

This potion will restore a character back to life from the Brink of Death and leaves them at 1 Body Point; the Death System is not used. *Alchemical Life* must be used on the character within 5 minutes – 10 minutes if the character has the Coma skill – of their character going to the Brink of Death. The character’s body must be relatively intact and the head must be attached.

*Alchemical Life* will only work on a character once per day – a period of time from 7am to 7am the next day. When you use an *Alchemical Life* on a character, you should write “Alchemical Life” on their character card along with the date, time and your initials; this allows another player to verify whether the character has already been “lived” earlier that day. If the spell is cast on a character twice in the same day, the second use has no effect.

Extend Duration has no effect on this poison. This potion is inherently a contact potion.

**Doppelganger Potion** Forms: Ingested, Contact

**Duration:** 1 Hour

This potion will change the outward appearance of the imbiber into that which is specified at the time of creation. It will only change the race of the imbiber and therefore will not exactly copy a specific character. The imbiber gains none of the special abilities of that race, even physical characteristics. So, if the imbiber is turned into a troll, they will look like a troll, but not gain the trolls strength or vulnerability to fire. If the imbiber is human, for example, and they drink a potion that transforms the imbiber into a human, the potion will have no effect. The imbiber must wear their normal garb/custom, to indicate that their basic appearance has not changed. In addition, the character’s voice is unaffected by the potion. The imbiber will be identifiable to anyone who knew them in their natural form.

When the potion is created, in addition to the major component, a drop of blood of the creature to be copied is required.

**Eye Drops of True Sight** Forms: Contact

**Duration:** 10 Minutes

These eye drops grants the user the ability to see the true nature of characters and creatures revealing cloaked undead, possessed people, shaped changed creatures, characters or creatures hiding in shadows, melding with nature, invisible, etc. This potion will not reveal the character’s true nature, i.e. if they are a follower of a faith or if they are good or evil.

**Fire Potion 48 pts** Forms: Ingested

**Duration:** *Special*

The character using this potion can breathe fire three times for 48 points of fire damage each time. The three attacks must be used within one hour or the character takes the damage of the remaining charges of the potion.

Extend Duration has no effect on this potion.

**Remove Curse** Forms: Ingested, Contact

**Duration:** Instant

This potion will remove all curses currently affecting the character.

Extend Duration has no effect on this potion.

**Stamina Potion +24** Forms: Ingested, Contact

**Duration:** 10 Minutes

Using this potion adds +24 Body Points that can be healed.

**Strength Potion +12** Forms: Ingested, Contact

**Duration:** Instant

This potion grants the user a +12 Strength Bonus, Non-Combinable which allows one feat of great strength or +12 points of damage for the duration of the potion.

**Superior Stamina Potion +6** Forms: Ingested, Contact

**Duration:** 1 Hour

Using this potion adds +6 Body Points that can be healed.

**Superior Strength Potion +3** Forms: Ingested, Contact

**Duration:** 10 Minutes

This potion grants the user a +3 Strength Bonus, Non-Combinable which allows one feat of great strength or +3 points of damage for the duration of the potion.

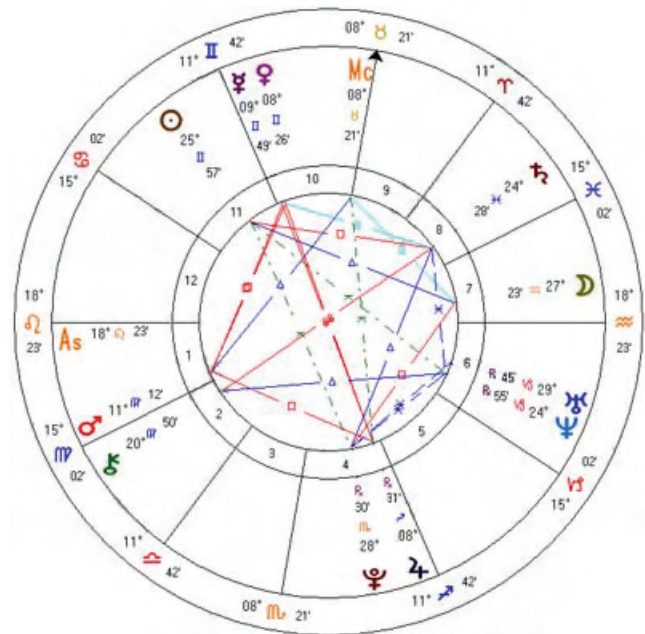

## Solutions School

### Using Acids

Acids affect corporeal undead normally, but has no effect on non-corporeal undead. The following chart shows how acids affect various substances. Note: metals do not include Mithril or higher, which no known acid will effect. There is no known acid that can affect glass.

Acid Effect Table				
	Parchment/ Cloth	Wood/Rope/ Leather/Bone	Metal/ Ceramic	Stone/ Gems
Rank 2	4x4x1 in	1x1x1 in		
Rank 3	12x12x1 in	4x4x1 in	1x1x1 in	
Rank 4	24x24x1 in	12x12x1 in	4x4x1 in	1x1x1 in
Rank 5	36x36x1 in	24x24x1 in	12x12x1 in	4x4x1 in
Rank 6	4x4x1 ft	36x36x1 in	24x24x1 in	12x12x1 in
Rank 7	5x5x1 ft	4x4x1 ft	36x36x1 in	24x24x1 in
Rank 8	6x6x1 ft	5x5x1 ft	4x4x1 ft	36x36x1 in
Rank 9	7x7x1 ft	6x6x1 ft	5x5x1 ft	4x4x1 ft
Rank 10	8x8x1 ft	7x7x1 ft	6x6x1 ft	5x5x1 ft

## 2<sup>nd</sup> Rank Solutions

### 6 Point Acid **Forms:** Contact

**Duration:** Instant

This alchemical solution will cause 6 points of normal damage to a character. It will not destroy armor if simply thrown at the target. To destroy armor, clothing, items, etc., the player must apply the acid directly. The table at the beginning of this section details the effects of acids on various substances.

This alchemical item is inherently a contact substance. Extend Duration has no effect on this solution.

### 8 Point Sunwater **Forms:** Contact, Gaseous

**Duration:** Instant

This Solution does 8 points of direct body damage to undead only.

This alchemical item is inherently a contact substance. Extend Duration has no effect on this solution and cannot be applied to a weapon, only thrown.

### 8 Point Moonwater **Forms:** Contact, Gaseous

**Duration:** Instant

This Solution does 8 points of direct body damage to Solars and other good outsiders.

This alchemical item is inherently a contact substance. Extend Duration has no effect on this solution and cannot be applied to a weapon, only thrown.

### Alchemical Lubricant **Forms:** Contact

**Duration:** 10 Minutes

This Solution covers four square feet and creates a frictionless surface. It is impossible to properly use any item covered in it or walk upon a surface covered with it. This Solution cannot be thrown and must be applied. To represent the area, the player should use tape, garland, or a sheet.

This alchemical item is inherently a contact substance. This recipe will produce 2 alchemical items when made.

### Embalming Oil **Forms:** *Special*

**Duration:** Instant

This Solution is used with the Embalming skill to preserve an entire body. Only characters with the Embalming skill can use this Solution correctly.

This alchemical item is inherently a contact substance. Extend Duration has no effect on this solution.

### Oil of Copper Blade **Forms:** Special

**Duration:** 10 Minutes

This Solution coats a weapon with copper for its duration. The character should suffix their damaged called with "...Copper".

This solution is only able to be applied to a weapon and cannot be drunk or made gaseous.

### Oil of Silver Blade **Forms:** Special

**Duration:** 10 Minutes

This Solution coats a weapon with silver for its duration. The character should suffix their damaged called with "...Silver".

This solution is only able to be applied to a weapon and cannot be drunk or made gaseous.

### Paste of Stickiness **Forms:** Contact

**Duration:** Permanent

This Solution covers one square foot of material and has similar effects to an *Attachment* spell. The effects of a *Paste of Stickiness* are permanent. The effect can be broken with normal strength, which takes 5 seconds.

This alchemical item is inherently a contact substance. Extend Duration has no effect on this solution. This recipe will produce 2 alchemical items when made.

### Rank 2 Solvent **Forms:** Contact

**Duration:** Instant

This will immediately destroy the effects of a *Paste of Stickiness*, *Alchemical Lubricant*, or any lesser adhesive. Once applied, all lesser adhesives affecting the character or item are instantly destroyed.

This alchemical item is inherently a contact substance. Extend Duration has no effect on this solution.

This recipe will produce 2 alchemical items when made.

### Smelling Salts **Forms:** Contact

**Duration:** Instant

Applying this solution to an unconscious character will wake them up. This will wake a character up who has been waylaid, affected by a *Dust of Sleep*, or under the effects of a *Sleep* spell. The character must be at 1 Body Point or more.

This alchemical item is inherently a contact substance. Extend Duration has no effect on this solution.



**3<sup>rd</sup> Rank Solutions****12 Point Acid**                      **Forms:** Contact**Duration:** Instant

This alchemical solution will cause 12 points of normal damage to a character. It will not destroy armor if simply thrown at the target. To destroy armor, clothing, items, etc., the player must apply the acid directly. The table at the beginning of this section details the effects of acids on various substances.

This alchemical item is inherently a contact substance. Extend Duration has no effect on this solution.

**16 Point Sunwater**                      **Forms:** Contact, Gaseous**Duration:** Instant

This Solution does 16 points of direct body damage to undead only.

This alchemical item is inherently a contact substance. Extend Duration has no effect on this solution and cannot be applied to a weapon, only thrown.

**16 Point Moonwater**                      **Forms:** Contact, Gaseous**Duration:** Instant

This Solution does 16 points of direct body damage to Solars and other good outsiders.

This alchemical item is inherently a contact substance. Extend Duration has no effect on this solution and cannot be applied to a weapon, only thrown.

**Dust of Sleep**                      **Forms:** Contact**Duration:** 10 Minutes

This Solution will render the targeted character asleep for the duration, or until the character takes 1 or more points of damage.

This alchemical item is inherently a contact substance.

**Paste of Binding**                      **Forms:** Contact**Duration:** 10 Minutes

This Solution covers an entire person with a sticky goo that instantly hardens. The effect is similar to a *Bind Spell*. The targeted character can free either their arms or legs with a +3 Strength Bonus or more and takes five seconds.

This alchemical item is inherently a contact substance.

**Oil of Armor +4**                      **Forms:** Contact**Duration:** 10 Minutes

When this Solution is applied to metal or leather armor it increases the armor value by 4 points. These new Armor Points are the first to go after an *Armor* spell. Though these new Armor Points are not able to be repaired, the standard armor degradation rules apply. Finally, the Armor Points gained cannot be more than the Base Armor Points of the armor when it is fully repaired.

This solution is only able to be applied to armor and cannot be drunk or made gaseous.

**Oil of Flame Blade**                      **Forms:** Contact**Duration:** 10 Minutes

This Solution will make any weapon it is put on burst into flames and allows the weapon to swing for normal fire damage for the duration. The weapon will shed light as per the *Light* spell and will also act as a *Match* spell and can set flammable things on fire.

This solution is only able to be applied to a weapon and cannot be drunk or made gaseous.

**Oil of Striking +1****Duration:** 10 Minutes**Forms:** Contact

Application of this Solution to a weapon increases the base weapon damage by 1 for the duration. The weapon takes on no other special qualities and can still be affected by a *Shatter* or *Blast* spell or Shatter skill as normal.

This solution is only able to be applied to a weapon and cannot be drunk or made gaseous.

**Rank 3 Solvent****Duration:** Instant**Forms:** Contact

This Solution will instantly destroy the effects of a *Paste of Binding*, giant spider's web, or any other lesser adhesive. Once applied, all adhesives affecting the character or item are destroyed.

This alchemical item is inherently a contact substance. Extend Duration has no effect on this solution. This recipe will produce 2 alchemical items when made.

**4<sup>th</sup> Rank Solutions****18 Point Acid****Duration:** Instant**Forms:** Contact

This alchemical solution will cause 16 points of normal damage to a character. It will not destroy armor if simply thrown at the target. To destroy armor, clothing, items, etc., the player must apply the acid directly. The table at the beginning of this section details the effects of acids on various substances.

This alchemical item is inherently a contact substance. Extend Duration has no effect on this solution.

**24 Point Sunwater****Duration:** Instant**Forms:** Contact, Gaseous

This Solution does 24 points of direct body damage to undead only.

This alchemical item is inherently a contact substance. Extend Duration has no effect on this solution and cannot be applied to a weapon, only thrown.

**24 Point Moonwater****Duration:** Instant**Forms:** Contact, Gaseous

This Solution does 24 points of direct body damage to Solars and other good outsiders.

This alchemical item is inherently a contact substance. Extend Duration has no effect on this solution and cannot be applied to a weapon, only thrown.

**Dust of Rot****Duration:** Instant**Forms:** Contact

This Solution will destroy four square feet of non-living organic material, will permanently destroy up to 20 points of leather armor, and has no effect on undead. To destroy leather armor worn by a character, the spell packet must hit the armor.

This alchemical item is inherently a contact substance. Extend Duration has no effect on this solution.

**Oil of Armor +8****Forms:** Contact**Duration:** 10 Minutes

When this Solution is applied to metal or leather armor it increases the armor value by 8 points. These new Armor Points are the first to go after an *Armor* spell. Though these new Armor Points are not able to be repaired, the standard armor degradation rules apply. Finally, the Armor Points gained cannot be more than the Base Armor Points of the armor when it is fully repaired.

This solution is only able to be applied to armor and cannot be drunk or made gaseous.

**Oil of Mithril Blade****Forms:** Contact**Duration:** 10 Minutes

This Solution coats a weapon with Mithril for its duration. The character should suffix their damage called with "Mithril". The weapon takes on no other special qualities and can still be affected by a *Shatter* or *Blast* spell or Shatter skill as normal.

This solution is only able to be applied to a weapon and cannot be drunk or made gaseous.

**Oil of Striking +2****Forms:** Contact**Duration:** 10 Minutes

Application of this Solution to a weapon increases the base weapon damage by 2 for the duration. The weapon takes on no other special qualities and can still be affected by a *Shatter* or *Blast* spell or Shatter skill as normal.

This solution is only able to be applied to a weapon and cannot be drunk or made gaseous.

**Rank 4 Universal Solvent****Forms:** Contact**Duration:** Instant

This Solution will instantly destroy any known adhesive. Once applied, all adhesives affecting the character or item are destroyed. In addition, any alchemical substances on weapons, armor, or characters are also destroyed.

*For example, Arthos applies an Oil of Striking +3 and an Oil of Mithril Blade to his normal bastard sword and runs into battle. During the battle, he is disarmed and the enemy applies a Universal Solvent to the weapon. Later when Arthos recovers his sword it is once again a normal bastard sword, no longer under the effects of the potent alchemy.*

To correctly use the Universal Solvent, a character must apply the solvent directly; this alchemical item cannot be thrown.

This alchemical item is inherently a contact substance. Extend Duration has no effect on this solution.

**Wall of Light****Forms:** Contact**Duration:** 10 Minutes

This solution will create a wall of any shape up to 10 feet long. Any undead character that touches or steps through the wall takes 14 points of damage. The wall cannot be destroyed by moving the sands; once placed the wall will last until it expires.

This solution cannot be made gaseous.

**5<sup>th</sup> Rank Solutions****24 Point Acid****Forms:** Contact**Duration:** Instant

This alchemical solution will cause 24 points of normal damage to a character. It will not destroy armor if simply thrown at the target. To destroy armor, clothing, items, etc., the player must apply the acid directly. The table at the beginning of this section details the effects of acids on various substances.

This alchemical item is inherently a contact substance. Extend Duration has no effect on this solution.

**32 Point Sunwater****Forms:** Contact, Gaseous**Duration:** Instant

This Solution does 32 points of direct body damage to undead only.

This alchemical item is inherently a contact substance. Extend Duration has no effect on this solution and cannot be applied to a weapon, only thrown.

**32 Point Moonwater****Forms:** Contact, Gaseous**Duration:** Instant

This Solution does 32 points of direct body damage to Solars and other good outsiders.

This alchemical item is inherently a contact substance. Extend Duration has no effect on this solution and cannot be applied to a weapon, only thrown.

**Dust of Rust****Forms:** Contact**Duration:** Instant

This solution will destroy four square feet of normal metal, copper, silver, or gold and will permanently destroy up to 20 points of metal armor. To destroy metal armor worn by a character, shields, or weapons, the spell packet must hit the armor, shield, or weapon. Dwarven crafted items are not destroyed.

This alchemical item is inherently a contact substance. Extend Duration has no effect on this solution.

**Oil of Armor +12****Forms:** Contact**Duration:** 10 Minutes

When this Solution is applied to metal or leather armor it increases the armor value by 12 points. These new Armor Points are the first to go after an *Armor* spell. Though these new Armor Points are not able to be repaired, the standard armor degradation rules apply. Finally, the Armor Points gained cannot be more than the Base Armor Points of the armor when it is fully repaired.

This solution is only able to be applied to armor and cannot be drunk or made gaseous.

**Oil of Ghost Blade****Forms:** Contact**Duration:** 10 Minutes

This Solution will make the striking surface of any weapon it is put on ethereal for 10 minutes allowing the weapon to do direct body damage and effect both corporeal and non-corporeal undead for the duration. This Solution does not make the weapon unshatterable, however. While the weapon is under the affect of the *Ghost Blade*, it will swing for "Ghost".

This solution is only able to be applied to a weapon and cannot be drunk or made gaseous.

**Oil of Preservation**      **Forms:** Contact**Duration:** 10 Minutes

This Solution will, when applied to a character in their Death Count, stop their count for the duration of this solution. When the duration ends, the character's Death Count continues. This solution has no effect on a character not in their Death Count.

This solution is inherently contact and cannot be made gaseous.

**Oil of Stone to Flesh**      **Forms:** Contact**Duration:** Instant

This solution will restore a character who as been turned to stone by any means: Medusa's or Basilisk's Gaze, Druid *Flesh to Stone* spell, Sorcery, a curse, etc.

This alchemical item is inherently a contact substance. Extend Duration has no effect on this solution.

**Oil of Striking +3**      **Forms:** Contact**Duration:** 10 Minutes

Application of this Solution to a weapon increases the base weapon damage by 3 for the duration. The weapon takes on no other special qualities and can still be affected by a *Shatter* or *Blast* spell or Shatter skill as normal.

This solution is only able to be applied to a weapon and cannot be drunk or made gaseous.

**6<sup>th</sup> Rank Solutions****30 Point Acid**      **Forms:** Contact**Duration:** Instant

This alchemical solution will cause 30 points of normal damage to a character. It will not destroy armor if simply thrown at the target. To destroy armor, clothing, items, etc., the player must apply the acid directly. The table at the beginning of this section details the effects of acids on various substances.

This alchemical item is inherently a contact substance. Extend Duration has no effect on this solution.

**40 Point Sunwater**      **Forms:** Contact, Gaseous**Duration:** Instant

This Solution does 40 points of direct body damage to undead only.

This alchemical item is inherently a contact substance. Extend Duration has no effect on this solution and cannot be applied to a weapon, only thrown.

**40 Point Moonwater**      **Forms:** Contact, Gaseous**Duration:** Instant

This Solution does 40 points of direct body damage to Solars and other good outsiders.

This alchemical item is inherently a contact substance. Extend Duration has no effect on this solution and cannot be applied to a weapon, only thrown.

**Oil of Armor +16**      **Forms:** Contact**Duration:** 10 Minutes

When this Solution is applied to metal or leather armor it increases the armor value by 16 points. These new Armor Points are the first to go after an *Armor* spell. Though these new Armor Points are not able to be repaired, the standard armor degradation rules apply. Finally, the Armor Points gained cannot be more than the Base Armor Points of the armor when it is fully repaired.

This solution is only able to be applied to armor and cannot be drunk or made gaseous.

**Oil of Striking +4**      **Forms:** Contact**Duration:** 10 Minutes

Application of this Solution to a weapon increases the base weapon damage by 4 for the duration. The weapon takes on no other special qualities and can still be affected by a *Shatter* or *Blast* spell or Shatter skill as normal.

This solution is only able to be applied to a weapon and cannot be drunk or made gaseous.

**Oil of Magic Blade**      **Forms:** Contact**Duration:** 10 Minutes

This Solution coats a weapon allowing it to swing for magic for its duration. The character should suffix their damage called with "Magic". The weapon takes on no other special qualities and can still be affected by a *Shatter* or *Blast* spell or Shatter skill as normal.

This solution is only able to be applied to a weapon and cannot be drunk or made gaseous.

**Superior Oil of Armor +4**      **Forms:** Contact**Duration:** 1 Hour

When this Solution is applied to metal or leather armor it increases the armor value by 4 points. These new Armor Points are the first to go after an *Armor* spell. Though these new Armor Points are not able to be repaired, the standard armor degradation rules apply. Finally, the Armor Points gained cannot be more than the Base Armor Points of the armor when it is fully repaired.

This solution is only able to be applied to armor and cannot be drunk or made gaseous.

**Superior Oil of Striking +1**      **Forms:** Contact**Duration:** 1 Hour

Application of this Solution to a weapon increases the base weapon damage by 1 for the duration. The weapon takes on no other special qualities and can still be affected by a *Shatter* or *Blast* spell or Shatter skill as normal.

This solution is only able to be applied to a weapon and cannot be drunk or made gaseous.



## Sorcerer Advanced Career

Below is the list of skills available to players who wish to play a Sorcerer. For a full description of the skill, see Chapter 5.

Sorcery Skill List					
Skill	Cost	Duration	Prerequisite Skill	Purchase	Tagged
Create Scroll	5	Constant	Read Magic	Once	No
Sorcery Lore	2	Constant	Create Scroll, 4 <sup>th</sup> Rank of Any School	Once	No
Dissection	5	Constant	Sorcery Lore	Once	No
Identify Components	3	Constant	Sorcery Lore, Dissection	Once	No
Cosmic Focus	0	Constant	Sorcery Rank 1	Once	No
Sorcery Rank 1	8	Constant	Sorcery Lore	Once	No
Sorcery Rank 2	10	Constant	Sorcery Rank 1	Once	No
Sorcery Rank 3	10	Constant	Sorcery Rank 2	Once	No
Sorcery Rank 4	10	Constant	Sorcery Rank 3	Once	No
Sorcery Rank 5	10	Constant	Sorcery Rank 4	Once	No
Sorcery Rank 6	10	Constant	Sorcery Rank 5	Once	No
Sorcery Rank 7	15	Constant	Sorcery Rank 6	Once	No
Sorcery Rank 8	20	Constant	Sorcery Rank 7	Once	No
Sorcery Rank 9	25	Constant	Sorcery Rank 8	Once	No
Sorcery Rank 10	30	Constant	Sorcery Rank 9	Once	No

### Special Notes for the Sorcery Skill List

There are no special notes for the Sorcery Skill List.



## The Sorcerer

Practitioners of the high magic of sorcery cast magic through a complex set of steps called a ritual.

Through advanced study of the arcane arts, a Sorcerer uses their knowledge to shape and bend magic to their will. As the Sorcerer gains more knowledge, the complexity and potency of the rituals they can cast also increases. A Sorcerer forces their will upon the universe through the practicing of their art. Unlike low magic, rituals are more powerful and last longer.

These spell casters are able to make permanent magical effects, whether on a person or upon an item. Magic swords, items of defense and items capable of storing raw power and spells are among some of the effects a Sorcerer can create.

A Sorcerer who has mastered their trade is truly a frighteningly powerful person, but there is a drawback to all this power. The Sorcerer must prepare their magic ahead of time, taking up to several hours to cast the rituals. Given the time, resources and will, there is little a powerful, accomplished Sorcerer cannot achieve.

Few people who study sorcery advance past the third rank of sorcery. There are those dedicated and accomplished practitioners who learn the fourth and even harder, fifth rank of sorcery. Finally, a practitioner who studies and works for years and years may be able to learn Sorcery Rank 6 and become one of the exceptionally rare individuals to ever do so.

## Scroll Rules

All scrolls are written in the Magic language with English characters. Below are the rules for creating scrolls.

### Creating Scrolls

All scrolls must be made in-game and they must be made with the aid of a Ritual Dish of Scroll Creation. A Magic Marshal must be present out-of-game to verify that a scroll has been created properly. The Marshal will stamp and sign the scroll when it is created.

To create a scroll, a character must do the following:

- All scrolls must be created using a Ritual Dish of Scroll Creation and cost the character a number of coins per Power Point in the spell as given in the table below. All spells cost a minimum of 1 Power Point to scribe, even ones with a 0 Power Point cost.

Spell Rank	Cost per Power Point
Rank I	1 copper piece
Rank II	2 copper pieces
Rank III	3 copper pieces
Rank IV	4 copper pieces
Rank V	1 gold piece

The coins used in the creation of a scroll can be any type of coinage so long as the total value equals what is listed in the chart.

In-game, the coins will dissolve into the dish and charge it making it ready for use. Out-of-game, the coins will go to the Magic Marshal.

- Place a piece of paper, parchment, or vellum into the dish. In-game, the coins will be woven into the threads of the paper, making it suitable for the scribing of a spell.
- The player must then write the spell's verbal on the paper. While they do this, they may not consult any out-of-game "cheat sheet" of the spell's verbal, however, they may consult an in-game spell book. **The process of scribing the scroll takes 1 minute per Power Point of the spell.** If the character is interrupted while scribing the scroll, the Power Points are lost and the scroll disappears. A player cannot stop scribing a scroll halfway through and then start again later.
- When the time for scribing the scroll has elapsed, the player must roll on the Scroll Creation Success Table (see below) to see if the scroll was scribed successfully. A Magic Marshal, who will also make sure that the spell's verbal was written correctly, must witness this roll.
- The player must take the Power Points used to cast the spell and have them stapled to the scroll, have the Magic Marshal stamp both the scroll and the Power Point tags with the appropriate stamp, and sign and date the scroll out-of-game.

During the scribing of the scroll, the Magic Marshal should inform the player when they have reached half of the required time, three-fourths of the required time, full time, and finally double time. The player may use this information in-game to help them determine when they want to stop the scribing. The player must always complete the full verbal for the spell, but they may choose to speed up or slow down their performance affecting their time bonus accordingly.

Use the following tables to calculate the chance for success in creating a scroll. The character should use percentile dice to determine the success or failure of their work. Treat an effective percentile die roll plus modifier of less than 01 as 01 and treat a roll of greater than 100 as 100.

Scroll Creation Base Table	
Die Roll	Result
01-05	The spell being scribed is cast upon the scrivener. The scroll disappears.
06-15	The scroll disappears.
16-85	The scroll is successfully created.
86-95	The scroll is successfully scribed, and it cost only half (rounded up) the normal number of Power Points to create the scroll.
96-100	The scroll is successfully scribed, and it cost no Power Points to create the scroll.

Scroll Creation Modifier Table

Modifier	Description
-1	For every Power Point in the spell being scribed.
+2	For every rank of the school of magic of the spell that the scrivener knows.
-5	For taking less than the normal amount of time to scribe the scroll, down to 75% of the normal amount.
-10	For taking less than 75% of the normal amount of time to scribe the scroll, down to 50% of the normal amount.
Fail	For taking less than 50% of the normal amount of time.
+5	For taking double the amount of time to scribe the spell.
-5	For using any kind of ordinary blank paper.
+0	For using parchment paper.
+5	For using vellum.
+5	For embedding double the normal amount of coinage into the paper used for scribing the scroll.
+0	For scribing the spell as required.
+1	For using a real quill and ink to scribe the spell.
+1 to +5	For exceptional roleplay while scribing the scroll.
Fail	For making a mistake in the spell's verbal.

*For example, Siona wants to make a Life spell scroll. He spends 15 minutes scribing the spell's verbal onto a piece of vellum procured from the Guild of Arcane Lore and used 12 silver pieces to charge the dish. Siona tells the marshal he is finished and they calculate the roll needed to succeed. -12% for the Power Point Penalty, +8% for knowledge of the Healing School, +0% for time taken - Siona needs to have taken 24 minutes to gain the bonus, +5% for using vellum paper, and finally +2% for good roleplaying during the scribing of the scroll. That gives Lisa Tomaszewski a total of +3%, which means the player must roll a 13 or higher to succeed.*

A player may substitute a pre-generated scroll for their hand written one once they have completed scribing the scroll successfully. In this case, the Power Points are stapled to this new scroll and the old hand written one should be torn up.

## Sorcery Rules

Below are the rules for casting and creating new rituals.

### Learning and Scribing Rituals

In order for a character to read or write a ritual, that character must know the Sorcery Lore skill. No rolls are made to copy a ritual from one source to another, but a Magic Marshal must sign the new copy and the copying must be performed in-game. However, once a character has a copy of a ritual, they may make as many copies of that ritual as they wish; even mechanically reproducing them in between Events. All of these copies must be signed by a Magic Marshal.

Every in-game ritual must have the following out-of-game information:

- Ritual Name
- Rank
- Alignment
- Temporary Power Point Cost
- Permanent Power Point Cost
- Casting Time
- Duration
- Component List
- Marshal Signature

Additionally, the ritual must have the in-game description of the roleplaying steps needed to cast the ritual.



### *Casting a Ritual*

The player must actually perform a magical ritual in-game. The fundamental rule on how the ritual is written and performed is that any other player who witnesses the ritual is aware that a ritual is being performed. Ideally, a player performing a ritual should not take time out for any out-of-game activity, for example meal breaks, while they perform the ritual.

The player is responsible for supplying their own props and making sure that all cards, tags, labels, etc., are available. For example, a player who casts a Ritual of Warding must have the item tag for the ritual component and the yellow duct tape, glow rope, garland, or some other representation of the Ward.

The ritual fails if the primary caster is distracted while they perform the ritual. A caster can be distracted if they are interrupted by any of the means that can interrupt the casting of a normal spell. In addition, if while performing the ritual the caster is affected by any spell that affects the movement of their body, like a *Paralysis* spell, the freedom of their mind, like an *Enslavement* spell or the Hypnosis skill, or if the caster simply stops performing the ritual then the ritual fails and all components used up to that point and the listed temporary Power Points are lost.

If a caster other than the primary caster is distracted or leaves the ritual, the primary caster is responsible for covering their temporary and permanent Power Points. Additionally, any Knowledge Bonus from that caster is lost.

If a participant in the ritual is distracted, as opposed to the caster, then the ritual is not interrupted. However, the penalty for having a participant in the ritual still applies and any Knowledge Bonus is lost. For example, if a caster is performing a Ritual of Circle of Protection and is investing a participant as a part of the ritual, then if the participant is distracted or leaves the ritual, the participant's investiture is canceled.

If the target of a ritual – be it either a character or item – is removed from the ritual, the ritual automatically fails. The target does not need to concentrate during the ritual; attempting to harm or distract the target does not interfere with the ritual unless the target is removed or destroyed.

At the end of the ritual, the player must roll on the Ritual Success Table (see page 103). The roll on this table determines whether the ritual succeeds or fails.

The key components necessary to cast the ritual are used up at half the casting time (50% Casting Time) and cannot be used in another ritual again. Additionally, the components disappear at the end of the ritual; there are some exceptions to this rule and noted in the ritual itself. If a ritual is interrupted, then any components used up to that point are expended and those not yet used are unaffected.

During the casting of any ritual, a Magic Marshal **must** be present. The Magic Marshal will make sure that an appropriate ritual is being performed, and will supervise the final die roll that determines the result of the ritual.

Every character that can perform sorcery must have an in-game ritual spell book to cast a ritual. This ritual book will normally be prepared under the supervision of the character's instructor in sorcery. A character must review the casting of any ritual in a ritual book before or during the ritual itself. If a character loses their ritual book in-game, they must recover it, re-create it, or find another before they can perform rituals again.

Some rituals cost permanent Power Points in addition to temporary Power Points. If a ritual is performed, the caster loses both the permanent and temporary Power Points whether the ritual succeeds or fails at the end of the ritual. If a caster spends permanent Power Points, the Magic Marshal will write the loss on the back of the player's Character Card, and will make sure the player removes the permanent Power Point loss from the player's tags for the rest of the Event. **Any Permanent Power Point loss is permanent, even if the ritual is later dispelled or the item created is destroyed.** The only exception is investiture, if the character is de-invested or the circle is destroyed, the Power Point is returned to the character.

If, at the end of a ritual, the caster does not have enough Power Points to cast the ritual, the ritual fails, no Power Points are lost, and components not dispersed are not expended. For rituals that have a variable number of Power Points or are to embed a spell or ritual into an item, the spells or rituals are only embedded which the caster has Power Points for. For example, if a character attempts to embed ten *Life* spells into an item but only has enough Power Points for the Ritual of Embedding and five *Life* spells, then only five will be embedded.

The Magic Marshal is responsible for providing a watch, percentile dice, pen and the rules. However, the prudent player will have these supplies in case the marshal forgets something.

### *Additional Casters in a Ritual*

All rituals have a primary caster, usually just referred to as the caster, but the primary caster can have help casting a ritual. Up to two other casters, always referred to as assistant casters, can assist the primary caster for a total of three characters casting one ritual. Only the primary caster must have the minimum rank in Sorcery required to cast the Ritual. The primary caster must have the ritual in their ritual book. Each assistant caster must know at least Sorcery Rank 1 and must put in a minimum of one-quarter (round down, minimum 1) of the ritual's temporary Power Point cost towards the ritual, but the ritual's temporary Power Point cost must be paid in full after all





tallies. Assistant casters can follow all steps of the ritual as outlined by the primary caster's copy of the ritual, but must perform the minimum role-playing requirements for casting a ritual. This does not lower the time taken in the ritual, nor does it increase the number of components. Any caster in the ritual may volunteer any permanent Power Point loss if required by the ritual, but the primary caster is responsible for any permanent Power Point cost, if any, not covered by the other casters.

The Success Roll is made by the primary caster of the ritual. The Knowledge Bonus treats assistant casters as participants except they receive a +2% for being involved instead of the -2% for participants. All successes and penalties are treated equally among the casters.

During the ritual, an assistant caster may attempt to wrest control of the ritual from the primary caster if they know the rank of sorcery of the ritual being casted. Whoever has the most current Power Points – before subtracting for the Power Points lost to the ritual – wins control, and if the primary caster loses they become an assistant caster.

After a ritual is completed, any contest for control of the ritual will result in the primary caster winning control, the caster – or investee – with the highest current Power Points wins if the primary caster is not involved. Two groups of casters or investees vying for control total their current collective Power Point totals and the group with the highest amount wins. If there is a tie, then the status quo is maintained.

The primary caster must choose to accept a caster into the casting of their ritual; a caster must also be willing or made to be willing to help cast the ritual. A character cannot simply walk into a ritual and make themselves part of the ritual.”

### ***Additional Participants in a Ritual***

A ritual may have as many participants as is needed, required or desired. These participants may not donate any temporary Power Points to the casting of the ritual, but may donate permanent Power Points as they wish. The caster must choose to accept a participant into the casting of their ritual; a participant must also be willing or made to be willing to be part of a ritual. A character cannot simply walk into a ritual and make themselves part of the ritual. If a ritual is to be cast upon a person, they are not considered to be a participant; they are the target.

### ***Target of the Ritual***

**The target of the ritual is never considered a component.** The exception is the various undead creation rituals, in which case, the

body of the target is considered a component and should the ritual fail, the body is destroyed, For purposes of determining when this “component” is used, the target body is always used at the culmination of the ritual. There is no other effect on the character and the player can choose to resurrect if they are able.

### ***Duration of Rituals***

All rituals have a duration listed in the rituals description. Some rituals have an instant effect or only last for a short time such as a Tag Cycle. Others may last until the end of the current Event. Other rituals will last for months or may even be permanent. The duration starts when the ritual ends. For example, if the ritual was completed at 6:50 pm and only lasted a Tag Cycle, then the ritual will end in 10 minutes. Similarly, if a ritual with a duration of 1 Event was completed at noon on the Sunday of an Event, then the ritual ends when game is called, a few hours later.

### ***Creating Magic Items, Invokable versus Castable***

Any time you cast a ritual on an item, unless noted in the ritual's description, it becomes unbreakable. No amount of Strength Bonus, no low magic spell, no amount of damage, and all but the most powerful attacks of Dragons or Hierarchs can break a magic item. However, if the ritual ends or is dispelled in some way, then the item reverts back to its original properties; so if it was breakable before, it will be breakable again.

Just because a magic item is magical, does not mean it will swing for magic if it is a weapon. The ritual cast upon the weapon must explicitly state that the weapon will swing for magic. For example, casting a Ritual of Embedding on a normal sword will make that sword unbreakable, but it still swings for normal damage.

Rituals that make magic items that cast spells – Ritual of Minor Item Creation, Ritual of Item Creation, Ritual of Embedding, etc. – need to be declared either Invokable or Castable and recorded on the item card at the time of creation. All spells in that item must be either all Invokable or all Castable, you cannot mix the two.

To use a Castable item, the character should prefix the name of the spell with, “From this mystic item, I cast a...” For example, to invoke a wand with embedded Castable *Fireball* spells, the character would say, “From this mystic item, I cast a Fireball spell.”

For spells that are listed with a duration of Latent, an Invokable spell can be called to stop an attack, but cannot be cast upon another character. A Castable spell can be cast upon any character, but unless it has been already cast, cannot be invoked to stop an attack.

*For example, Dextralyn casts a Ritual of Embedding and embeds three Invulnerability spells and decides to make them Invokable. Later she is attacked and invokes the three Invulnerability spells one right after another. Once more, Dex creates an item with three Invulnerability spells in it, but makes them Castable. Now she can cast those spells on herself, but can still only have one Invulnerability on her at a time and can give them out to others.*

Non-latent spells – spells with a duration or are Instant – must also be declared as Invokable or Castable. For these spells, Invokable means that the spell can be delivered by touch from the item or caster, but cannot be thrown. This effect is in addition to any martial damage or skill that is normally used with a weapon. So, a long sword with an embedded Fireball spell would do 16 points of magic fire and 2

points of damage. Castable means that the spell can be thrown normally but cannot be touch cast from the item.

*For example, Thomas embeds three Fireball spells into a long sword and declares them Invokable. Later, he can now invoke a Fireball spell and strike someone with the sword to cause the effect. Had Thomas made the item Castable, he would not be able to strike his opponents with the sword, but could throw the Fireballs from the item.*

If the Latent or non-Latent spells are Castable, the character can still touch a character, even themselves, with a spell packet and deliver the spell.

If a character uses a magic item that lets the caster cast a spell and has a permanent Power Point cost associated with it the character invoking the item must pay the permanent Power Point cost each time the spell is cast.

### **Creating Magic Items – Ritual Limit**

No item can have more than four rituals cast upon it at any one time. This does not include the Ritual of Permanency. Therefore, a sword can have a Ritual of Elemental Magic Weapon, Ritual of Spell Shield, Ritual of Defense and Ritual of Attunement cast upon it. A Ritual of Permanent Embedding counts as one of these rituals even though a Ritual of Permanency is not needed to make it permanent. Also, once any type of ritual or effect is made permanent on an item that item may not have any more such rituals cast upon it

This rule cannot be circumvented by casting rituals on one item then making it part of the whole then casting rituals on the whole item. For example, a character cannot cast four rituals into a gem then have that gem forged into a sword and casting four more rituals on the sword. However, it is acceptable to have separate items attached or contained in one place. For example, a character can place a number of magic charms on a necklace, and wear the necklace; but the necklace cannot be attuned to attune all the items on the necklace simultaneously as well.

### **Undead Creation Rituals**

Unlike the undead creation spells of the Necromancy school, the undead created by a ritual can last longer than one Event. The player of the undead character is therefore obligated to play the creature until it is destroyed, or until two months, not two events have passed since the ritual was cast. Only when the undead creature is gone can the player's character be resurrected.

These rituals can be cast on a dead body or on a living character by delivering a Killing Blow at the end of the ritual. This ritual requires the body of the character to be turned into the undead character, the body of a different character **cannot** be substituted, **ever**. Should the ritual fail, and all components consumed, then the dead body is destroyed. If a living character was the target of this type of ritual, then there is no added effect and the character should continue their Death Count normally.

Undead creation rituals have an instantaneous effect and therefore cannot be dispelled with a Thaumaturgy School spell or any destroy sorcery spell. The appropriate ritual must be used to turn the character back or the undead character must be destroyed to end the ritual effect.

### **Components**

The common component of all rituals is Ritual Powder. This powder is normally available from the Sorcerers' Guild, Merchants' Guild, or other in-game sources. Ritual Powder is measured by the "thimble", using a standard thimble size. There are two types of Ritual Powder, White Ritual Powder (WRP) and Black Ritual Powder (BRP). White Ritual Powder must be used in white rituals and Black Ritual Powder must be used in dark rituals. White or Black Ritual Powder can be used in neutral rituals and can be mixed in any combination.

Other components may be listed for the ritual. These components must be collected by the character. They can sometimes find them at the Sorcerer's Guild. Other guilds may also be able to provide the components needed by the Sorcerer. It is up to the character to locate and acquire the needed components.

A character may never substitute one component for another. If the ritual calls for the Willing Blood of a Paladin, only the Willing Blood of a Paladin may be used. Even if that blood comes from a human, a Solar or a Dragon, it is the same component. If a character wishes to use a different component in a ritual, they must research a new version of that ritual. Players should read the section on creating new Sorcery for further information.

Some characters, especially monster types, might be worth more doses of a component being dissected. For example, the character is looking for Essences of a Memory Moss and discovers a creature called the Mother of all Memory Mosses. Instead of the two doses the character would normally get, they will receive four doses from dissecting the character. The Plot Committee will indicate on any special character if they yield more than the normal number of doses, the player does not need to ask. If the NPC's card does not say it gives more doses, then it does not.

### **Creating New Rituals**

Sorcery is the magic of creating magic. To this end, it is possible to create new rituals not listed in these rules. Below is a guideline for creating new rituals. All new rituals attempted through the use of these guidelines will only be permitted in-game with Rules Committee's approval. Approval of any new sorcery ritual does not guarantee that the sorcery ritual will be successful. Approval only means that the Sorcerer has been authorized to make the attempt, after which the results of the ritual will be made known as per the use of the standard Ritual Success Table with all of the appropriate modifiers.



**Rank 1:**

Temporary Power Point Cost: ..... 5-15  
 Casting time: ..... 5-15 Minutes  
 Components:  
 Ritual Powder: ..... 1-2 Doses  
 1 Basic Component:  
 1-2 Common Components:

**Rank 2:**

Temporary Power Point Cost: ..... 15-25  
 Casting time: ..... 10-20 Minutes  
 Components:  
 Ritual Powder: ..... 1-3 Doses  
 1 Basic Component:  
 1 Common Component:  
 1 Uncommon Component:

**Rank 3:**

Temporary Power Point Cost: ..... 25-35  
 Casting time: ..... 20-30 minutes  
 Components:  
 Ritual Powder: ..... 3-5 Doses  
 1 Basic Component:  
 1 Common component:  
 1 Uncommon component:  
 1 Rare component:

**Rank 4:**

Temporary Power Point Cost: ..... 35-45  
 Casting time: ..... 30-40 Minutes  
 Components:  
 Ritual Powder: ..... 4-6 Doses  
 1 Basic Component:  
 1 Common component:  
 1 Uncommon component:  
 1 Rare component:  
 1 Very rare component:

**Rank 5:**

Temporary Power Point Cost: ..... 45-60  
 Casting time: ..... 40-50 Minutes  
 Components:  
 Ritual Powder: ..... 5-8 Doses  
 1 Basic Component:  
 1 Common component:  
 1 Uncommon component:  
 1 Rare component:  
 1 Very rare component:  
 1 Unique component:

Generally speaking, no ritual Rank 5 or lower requires a permanent Power Point cost unless it lasts longer than 1 Event or has a permanent effect.

The Plot Committee has the final say on what components fit into each category such as common, rare, etc. Players are required to make their Ritual proposal in writing. This proposal must include:

- The desired effect of the ritual.
- The desired duration of the effect.
- A list of the proposed components needed.
- The proposed rank, Power Point cost, and time to cast.
- The exact roleplaying steps to be used, along with any in-game special effects that would be expected.

After approval, the character's chance of initial success is 50% after fulfilling these base requirements:

- 1 silver piece times the rank of the ritual.
- The number of doses of Ritual Powder the ritual requires.
- 10 minutes of in-game roleplaying equal to the rank of the ritual during the first Event of research. Then an additional month of out-of-game research when modifying an existing ritual or two months of out-of-game research for a new ritual.
- A single dose of each component.

To increase this success chance, the character may spend more time and money:

- +5% per extra event of role-playing up to a maximum of four extra Events.
- +1% per extra 1 silver piece spent.
- +25% bonus for modifying an existing ritual.
- +5% times (Character's Rank of Sorcery – Rank of Ritual being Researched)
- Special bonuses assigned by the Plot Committee, which could be either a positive or a negative bonus.

Maximum chance of success is always 95%.

After submitting the proposal, the Rules Committee will inform the player if the ritual will not be allowed in game or if the caster will never be able to cast the ritual. If approved, the character then spends the required time and rolls to determine the success of the research and tries to cast the ritual. If they succeed their research roll but the Rules Committee feels some aspect of the ritual is inappropriate – the Casting Time too short, wrong component, too little or too many Power Points etc – they will inform the player after they attempt to cast their new ritual, but with those changes, the ritual is learned. If they fail the research roll, the Rules Committee will inform the player after they failed to cast the new ritual that the roll failed and they should try again after researching at least another Event gaining the appropriate bonus, however the character cannot, and needs not, spend more money.

***Aligned Sorcery***

Most Sorcerers are neutral or Gray Sorcerers, owing allegiance to no greater power. However, there are Sorcerers who have dedicated themselves to service of the High Lord or Dark Lord. All Sorcerers start out as Gray Sorcerers, and later in their careers may choose to serve one of the two opposing sides. There are advantages and disadvantages to being a White or Dark Sorcerer. The player should see the Follower of Light and Servant of Darkness Advanced Careers for more information about these Sorcerers.

All rituals have one of five alignments: white only, white, neutral, dark, and dark only. A neutral or Gray Sorcerer may cast white, neutral, and dark rituals. A White Sorcerer may cast neutral, white, and white only rituals and may never cast dark or dark only rituals. Concordantly, a Dark Sorcerer may cast neutral, dark, and dark only rituals and may never cast white or white only.

White Sorcerers must use White Ritual Powder and cannot ever use Black Ritual Powder in their rituals. Dark Sorcerers must use Black Ritual Powder for dark and dark only rituals and can use either Black or White Ritual Powder in the casting of their neutral rituals. Gray Sorcerers can use White or Black Ritual Powder to cast neutral rituals, but must use White Ritual Powder for white rituals and Black Ritual Powder for dark rituals.



## Ritual Success Tables

Roll on the following table using percentile dice, adding any and all bonuses from the Modifier Tables below. Treat an effective percentile die roll less than 01 as 01, treat a roll of greater than 150 as 150.

Ritual Success Base Table	
Die Roll	Result
01-03	Caster(s) and all participants immediately go to the Brink of Death. Anyone watching the ritual goes to -1 Body Points. The ritual fails.
04-10	Caster(s) and all participants immediately go to the Brink of Death. The ritual fails.
11-20	Caster(s) and all participants immediately go to -1 Body Points. The ritual fails.
21-30	The ritual fails, but the caster(s) and any participants are unharmed.
31-50	The ritual succeeds but is flawed. The Magic Marshal will roll on a Ritual Flaw Table and inform the caster(s) of the results.
51-120	The ritual succeeds.
121-140	The ritual succeeds. In addition, one ritual component (chosen at random by the Magic Marshal) is <i>not</i> expended by performing the ritual. If the caster(s) of the ritual has dispersed <sup>†</sup> all the components and there is nothing that can be saved, then the caster(s) loses only half the temporary Power Points needed to cast the ritual.
141-150	The ritual succeeds. In addition, <i>none</i> of the ritual components are expended by performing the ritual. If the caster(s) of the ritual has dispersed <sup>†</sup> all the components and there is nothing to be saved, then the caster(s) loses no temporary Power Points to cast the ritual.

Ritual Success Modifier Tables	
Modifier	Description
<b>Ritual Bonus (Only One Modifier Applies)</b>	
+20	1 <sup>st</sup> Rank Ritual
+15	2 <sup>nd</sup> Rank Ritual
+10	3 <sup>rd</sup> Rank Ritual
+5	4 <sup>th</sup> Rank Ritual
0	5 <sup>th</sup> Rank Ritual
-5	6 <sup>th</sup> Rank Ritual
-10	7 <sup>th</sup> Rank Ritual
-15	8 <sup>th</sup> Rank Ritual
-20	9 <sup>th</sup> Rank Ritual
-25	10 <sup>th</sup> Rank Ritual

Ritual Success Modifier Tables (Cont.)	
Modifier	Description
<b>Time Bonus (Only One Modifier Applies)</b>	
-10	For taking less than the required time to cast the ritual, down to 75% of the normal time.
-20	For taking less than 75% of the normal amount of time to cast the ritual, down to 50% of the required time.
+5	For taking more than the required time to cast the ritual from 150% to 200% of the required time.
+10	For taking more than the required time to cast the ritual over 200% of the required time.
Fail	For taking less than 50% of required time to cast the ritual.
<b>Knowledge Bonus</b>	
+0.5	For each 4 <sup>th</sup> rank in a school of magic that the caster(s) knows.
+1	For each 5 <sup>th</sup> rank in a school of magic that the caster(s) knows.
+5	For each Rank of Sorcery that the caster(s) knows.
+2	For each assistant caster in the ritual.
-2	For each participant (not the target) in the ritual, apart from the caster(s).
+0.25	For each 4 <sup>th</sup> rank in a school of magic that an assistant caster or participant knows.
+0.5	For each 5 <sup>th</sup> rank in a school of magic that an assistant caster or participant knows.
+1	For each Rank of Sorcery that an assistant caster or participant knows.
-1	For every Build Point the caster(s) and participant(s) has spent on Warlock skills.
<b>Component Bonus</b>	
+1 to +5	Components that come from characters gain a +5 freshness bonus in the month they are collected. For every month after, bonus decreases by 1 down to 0. Herbal components gain a bonus of +1 in the month they are collected. This bonus lasts 3 months. All other components gain no freshness bonus. Only the best bonus for the component (not doses) is gained, regardless of the number of doses. The total freshness bonus for all components is +10.
+10	For using double the amount of Ritual Powder to perform the ritual.
-10	For using less than the required amount of Ritual Powder down to 75% of the required amount.
-20	For using less than 75% of the required amount of Ritual Powder down to 50% of the required amount.
-40	For using less than 50% of the required amount of Ritual Powder, down to 25% of the required amount.
Fail	For using less than 25% of the required amount of Ritual Powder down to no Ritual Powder at all.
<b>Performance Bonus</b>	
+0	For doing the ritual as written, and using tags or empty vials for a physical representation.
+1 to +5	For performing a ritual well enough for any one to easily tell and for exceptional roleplay.
+0.5	For each component in the ritual the player has the appropriate physical representation for, not per dose.
Fail	For not performing the ritual at all.

<sup>†</sup> Note, the following types of components are always considered dispersed: dusts, crushed components, essences, powders, ashes, and any type of fluids.

### **Timing, Marshalling, and Performance Bonus**

During the casting of a ritual, the Magic Marshal should inform the player when they have reached half of the required time, three-fourths of the required time, full time, then time and a half, and finally double time. The player may use this information in-game to help them determine when they want to stop the ritual. The player must always complete the full ritual as written, but they may choose to speed up or slow down their performance affecting their Time Bonus accordingly.

Additionally, the Magic Marshal may inform the player during the casting of the ritual that they have made a mistake by telling them “The ritual is getting harder to cast” or “An error was made.” Similarly if the caster does something to warrant a bonus, the marshal may tell the caster “The ritual got easier to cast” or “Good roleplay.” The marshal will be trained in the proper way to do this, but the player should be ready for these comments.

### **Ritual Flaw Tables**

If a ritual is flawed, the results of the ritual are not what the caster expected. Sometimes the ritual turns out better than the caster expected; sometimes there is some defect in the ritual’s result.

Each ritual has its own ritual flaw table. The flaw tables are maintained by the Senior Magic Marshals. They are altered from time to time, to prevent the players from becoming too familiar with the different ritual flaw possibilities. Therefore, whenever a ritual is performed, the Magic Marshal must ask a Senior Magic Marshal for a flaw table for that ritual. Typically, the flaw tables are kept in sealed envelopes; if the ritual is not flawed, then the envelope is not opened. If the ritual is flawed, only the Magic Marshal should open the envelope, read the table, and perform the die roll that determines the exact nature of the flaw.

Sometimes a ritual’s flaw will be obvious. For example, if a Ritual Circle turns out to be a Circle of Fire; sometimes the flaw will be obvious only to the caster – the ritual cost double the number of temporary Power Points – sometimes the flaw can only be detected over time. Regardless of the flaw, the flaw will always be revealed by an *Identify Magic* spell.

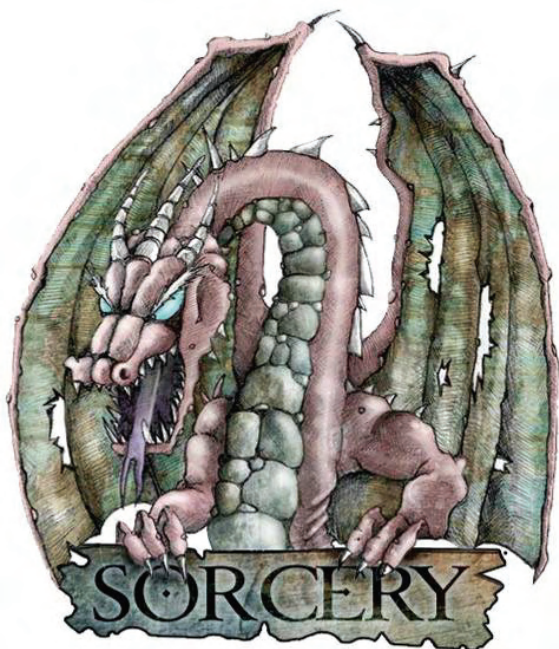

## **Rituals**

The following pages contain many of the common rituals found in LAIRE. This list is by no means complete. Some rituals you will have to learn about as you play your character. All of these rituals require components that must be learned about in-game.

### **Description Headings**

Each ritual has a description heading that summarizes some of the important information pertaining to each ritual. Below is an explanation of what each heading indicates.

#### **Component**

This is the components needed to cast the ritual.

Some components have a descriptor in parentheses juxtaposed to the components name that indicates the amount of that substance that constitutes a dose – the amount of that substance that is needed to cast that ritual.

#### **Amount**

The number of doses of the specified component needed in the casting of the ritual.

#### **Yield**

Some components come from characters. When a player dissects a character, this heading indicates how many usable doses they can get from that character. For a full description on how the Dissection skill works, see the Dissection skill description in Chapter 5.

#### **Rank**

This is the rank of the ritual.

#### **Alignment**

This is the alignment of the ritual. All rituals are either: white only, white, neutral, dark, or dark only.

#### **Temporary Power Points**

This is the total number of temporary Power Points needed to cast the ritual.

#### **Permanent Power Points**

This is the total number of permanent Power Points needed to cast the ritual. The permanent Power Points are not in addition to the temporary Power Points. Therefore, a ritual that requires 40 temporary Power Points and 2 permanent Power Points would cost the caster 40 Power Points, not 42.

The number in parentheses is the total number of permanent Power Points. So, if the number indicated was “1 (5 if Ritual Made Permanent)”, the caster would lose 5 not 6 Power Points if the ritual was made permanent.

If the text in parentheses says “Ritual Cannot be Permanencied” then the ritual cannot be permanencied with the use of the Ritual of Permanency. However, it still can be permanently embedded.

#### **Casting Time**

This is the amount of time required to cast the ritual.

#### **Duration**

This indicates how long the ritual will remain in effect. Rituals typically have one of the following durations: Instant, End of Tag Cycle, Event, or a number of months.

## Rank 1 Rituals

### Ritual of Elemental Energy 1

This ritual charges the caster with the energy of a particular element. After performing this ritual, the caster can throw an infinite number of bursts of elemental energy. Each burst of energy causes the amount of damage listed in the table below; the caster throws a spell packet and states the amount of damage followed by the type of damage; “Four Fire” for example. Only one spell packet can be thrown at a time. This damage is physical and therefore can be blocked by shields and any defense that stops physical attacks, such as the *Invulnerability* spell, but not by the *Negation* spell.

The type of damage associated with each element is:

Element	Effect
Fire	4 Normal Fire
Water	4 Normal Ice
Air	4 Normal Lightning
Earth	5 Normal Damage
Life	4 Normal Healing
Death	3 Normal Body

Note that healing damage does not heal the target, however, undead who are effected by normal damage will take double damage.

The caster can choose to cast this ritual upon themselves, upon another character, or upon an item. If cast on themselves or another character there is no in-game representation of the ritual. If this ritual is cast upon an item, a temporary item card must be made to indicate the magical nature of the item. As with other rituals that create magical items, the item is indestructible so long as the ritual lasts. A Ritual of Embedding is not needed to make an item with a Ritual of Elemental Energy 1.

If this ritual were to become permanent, it would give the caster the ability to invoke this ritual once per Event; the charge would last for 1 hour.

### Ritual of Elemental Weapon

This ritual allows the caster to instill any weapon with the power of one of the elements, which then allows the wielder to gain an elemental damage bonus to the weapon. For example, in the case of fire, the wielder would call “*Damage Fire*.” This damage is not magical.

The type of damage associated with each element is:

Element	Effect
Fire	Normal Fire
Water	Normal Ice
Air	Normal Lightning
Earth	+1 Normal Damage
Life	Normal Healing
Death	-1 Normal Body

For example, if an ordinary sword which normally does 2 points of damage is enchanted with elemental life, the wielder would call “Two Healing” when they used the weapon. Note that healing damage does not heal the target, however, undead who are effected by normal damage will take double damage.

If a Ritual of Permanency is cast on a weapon enchanted with the Ritual of Elemental Weapon, then the weapon will keep its continual elemental property, but it will not strike as a magical weapon.

A weapon of any quality is needed for this ritual and is the target of the ritual. Only one Ritual of Elemental Weapon can be cast upon a weapon at the same time. If a second ritual is cast, it will automatically fail. When this ritual is successfully cast on a weapon, it becomes unbreakable.

### Ritual of Magic Staff Creation

This ritual prepares a normal staff to accept all the other Magic Staff rituals. Upon successful completion of this ritual, the caster’s staff will be unbreakable and affect things with Damage Resistance: Mithril. The character should suffix the damaged called with “Mithril”. Only this staff gains this benefit and only the caster gains the benefit of the damage type modifier.

This ritual can be cast only on a staff, no other weapon substitutions are allowed. Only the caster can gain the benefits of this ritual. The caster may only have one caster’s staff at a time. If this ritual is cast upon a second staff, the first is destroyed and all Power Points, components, and rituals placed on that staff are lost forever.

### Ritual of Magic Transfer

This ritual allows the Power Points from any number of willing individuals to be transferred temporarily into a single spell caster. A character under the effects of an *Enslavement* or *Domination* spell or other mind controlling effect is not considered “willing”, but a character that is coerced by threat or promise or trickery would be. A spell caster can gain more than their normal maximum of Power Points using this ritual, however it does not change their maximum Power Point stat. The recipient of the Power Points does not have to be the caster of the ritual.

The recipient of the transferred Power Points has them until the end of the current Tag Cycle. If they are not all used by then, they are lost.

The person casting the ritual must have enough Power Points to cast the ritual; these Power Points cannot come from the Power Points received by casting this ritual. The people who are allowing their Power Points to be transferred must all be willing and must have unspent points available for the transfer.

### Ritual of Power Staff

This ritual allows the caster’s staff to be used in place of the gem component of the Ritual of Storing. The maximum number of Power Points that can be stored in the caster’s staff are 1/4 of the caster’s total number of Power Points.

This ritual must be cast upon the caster’s staff created in the Ritual of Magic Staff Creation. The caster’s staff is the target of the ritual. This ritual can only be cast once on the caster’s staff.



### Ritual of Rune Crafting

This ritual causes a rune of power to be inscribed on an object. When active, a rune constantly “watches” for any moving character within a 5 foot radius; when it sees one, the rune goes off, releasing its effect. The effects of the rune depend on its shape; an experienced Sorcerer can look at a rune and determine what its effects are from the rune’s design.

The Ritual of Rune Crafting involves inscribing the rune perfectly on the desired object with magical rune powder represented out-of-game by a piece of green chalk. The rune must be at least three inches tall, in the same proportions, orientation, and should be inscribed on a relatively flat surface. When a rune is first scribed, it is inactive; the scrivener must activate it in order for the rune to produce its effect.

Once active, a rune will go off if it sees a moving character move within 5 feet; if a rune cannot see you, then it will not go off. This means that a rune can be scribed on the inner lid of a box, on an inside page of a book, on the inner sill of a door, or in a totally dark room; the rune will not go off unless a moving character is visible within a 5 foot radius.

Additionally, the object the rune is scribed on must be stationary once the rune is activated. Should the entire object be intentionally moved after the rune is traced or fully active, it will go off, even if it is inside the object, such as a box, out to its full radius. For example, a character scribes a rune on one of the pages of a book. If the book is opened it will not go off, even if the page it is on is turned. However, if someone lifts the book, the rune will activate. If the rune was scribed on the inside bottom of a box and then covered, lifting the lid will not set the rune off, lifting its coverings will.

When a rune goes off, everyone within a 5 foot radius of the rune experiences its effect. The effects of a rune are magical in nature, so a defense that stops spells will protect against the effects of the rune; a *Reflection* or *Absorption* spell will protect against a rune’s effects, but a rune’s magic will not be reflected or absorbed. Normally a rune vanishes once it goes off.

When the Rune is scribed, the scrivener can embed additional “uses” of the rune’s effect into the rune. Up to a total of three uses can be in inscribed into one rune. If a multiple-use rune goes off, it will wait 3 seconds, then go off again if it still sees a moving character. Once a rune has gone off for the last time, it vanishes.

If a Ritual of Permanency is cast on a rune, it will remain scribed on the object after it has gone off. The rune will remain active, and resets itself after 5 minutes. If a multi use rune is permanencied, then each charge is reset after 5 minutes.

Cautious Sorcerers may inscribe more than one rune on a single object. If two different runes are activated simultaneously, characters experience their effects simultaneously and one defense against spells is required per effect.

The caster should (out-of-game) write the a description of the rune’s effects and its key word on a piece of paper, and place the paper and the Power-Point tags used to cast the rune in an envelope marked “Marshal Notes”. This envelope should be taped near the object on which the rune is scribed so a Marshal can properly supervise the rune’s activation.

### Ritual of Sanctification

This ritual allows the Sorcerer to sanctify a dead character against being raised as an undead. This ritual is attached to the character’s soul, not the body. So, if the body is destroyed, the ritual will remain in effect. This ritual must be cast on the last body the character had.

The character will be laid to rest and no necromancy or sorcery that creates undead will work on the character. The ritual may be dispelled by a ritual that dispels sorcery and must be cast on the body before any ritual or necromancy is cast. If the target of a successful sanctification resurrects, then the Ritual of Sanctification ends.

### Ritual of Specter Creation

This ritual turns a character into a Specter, an incorporeal lesser undead creature. The Specter is under the control of the caster of the ritual.

The player of the character who died must now play the newly-created undead creature. When the Specter is reduced to zero or less Body Points, the undead body dissolves into dust. The player takes one Death on their character card and may now go to the Healer’s Circle to have their spirit resurrected.

Specter lasts until destroyed or two months – the month the ritual was cast and the following month – if the target character can resurrect. If the character is un-resurrectable, then this ritual is permanent until the Specter is destroyed.

### Ritual of Storing

This ritual allows Power Points to be temporarily stored in a gem or an item which contains a gem. These Power Points may be used later by the caster or by another person. Any gems used to store Power Points must be legitimate in-game items approved by the Treasure Manager.

When this ritual is successfully cast on a gem, it becomes unbreakable. It cannot be destroyed by *Shatter*, *Blast*, or similar spells or abilities. When the enchantment wears off, the gem becomes breakable again.

A gem or item containing a gem must be worth 1 silver piece per Power Point to be stored. This ritual can be cast multiple times on the same gem up to maximum of the value of the gem.

No more than 25 Power Points can be stored in any one gem.

### Ritual of Warding

This ritual magically protects an area for the duration of the ritual. The area of effect may be any one building or room within a building. A building is defined in-game as any structure – man made or natural – that has at least three walls and a roof. Out-of-game, “lesser” structures that are defined as buildings can be warded. For example, a pavilion at an Event is deemed to be the Armory by the Magic Marshal, this structure would be wardable by the character.

When a ward is cast, it embeds itself in the walls, floor, and ceiling of the warded area; even if the physical structure is damaged, the ward will remain. After it is created, the ward’s caster can lower the entire ward by touching it and willing it down; when the caster ceases to touch the ward, it automatically goes up again. Any thing over the ward that is not over a designated portal when the caster raises the ward is ejected from the warded area in the direction it entered. A lowered ward will stay down if anything is placed across the ward’s boundary; when the boundary is no longer blocked, the ward goes up again.

When the caster creates a ward, they may designate entrances in the ward. A random word chosen by the caster at the time of the ritual

will cause an entrance to open when the word is spoken at an audible level in front of the entrance. This word will not affect any of the other entrances to the ward unless it is spoken loudly enough so that it can be heard at another entrance. When the word is spoken, the entrance will lower momentarily; it will stay open as long as anyone or anything more than a pound is placed in the opening. When an entrance is no longer blocked, it closes automatically.

Each designated entrance must be indicated on the Martial Notes, along with the ward word. To indicate the presence of a ward, the caster should place garland, yellow duct tape, glow rope, or some other suitable indication of a ward at each entrance to the structure.

Ward rituals of the same type do not stack, therefore two Rituals of Warding cannot be cast on the same building or room, but a room can have a Ritual of Warding Versus Life and a Ritual of Warding. Wards of the same type can share one common wall.

### Ritual of Warding Versus Life

This ritual acts exactly as the Ritual of Warding save that living beings as well as weapons or spells cast by living beings can not pass through. Undead and spells and weapons of the Undead can pass through the ward as if it were not there.

Ward rituals of the same type do not stack, therefore two Rituals of Warding Versus Life cannot be cast on the same building or room, but a room can have a Ritual of Warding Versus Life and a Ritual of Warding. Wards of the same type can share one common wall.

### Ritual of Warding Versus Undead

This Ritual acts exactly as the *Ritual of Warding* save that undead beings as well as weapons or spells cast by undead beings can not pass through. Living beings and spells and weapons of the living can pass through the ward as if it were not there.

Ward rituals of the same type do not stack, therefore two Rituals of Warding Versus Undead cannot be cast on the same building or room, but a room can have a Ritual of Warding Versus Undead and a Ritual of Warding. Wards of the same type can share one common wall.

## Rank 2 Rituals

### Ritual of Purity Shield

This ritual provides the recipient with a magical shield that will protect them from any alchemical effect, ingested or otherwise. After the alchemy shield is invoked to protect the recipient, it resets itself after 5 minutes.

The caster can choose to cast this ritual upon themselves, upon another character, or upon an item. If cast on themselves or another character there is no in-game representation of the ritual. If this ritual is cast upon an item, a temporary item card must be made to indicate the magical nature of the item. As with other rituals that create magical items, the item is indestructible so long as the ritual lasts. A Ritual of Embedding is not needed to make an item with a Ritual of Purity Shield.

The player should call “Ritual of Purity” when they invoke this defense.

### Ritual of Armor

This ritual creates a sorcerous defense that protects a character by granting them 20 Armor Points. No real armor needs to be worn for this ritual to protect the character. After the Ritual of Armor is expended; it resets itself after 5 minutes or if not completely damaged, it will reset itself 5 minutes after the last point of damage is taken.

This ritual is not stackable, combinable, linkable, wearable or usable with itself. For example, if you have two items such as rings, each with one of these rituals upon it, you cannot use both items to gain a +40 Armor Points, ever.

The caster can choose to cast this ritual upon themselves, upon another character, or upon an item. If cast on themselves or another character there is no in-game representation of the ritual. If this ritual is cast upon an item, a temporary item card must be made to indicate the magical nature of the item. As with other rituals that create magical items, the item is indestructible so long as the ritual lasts. A Ritual of Embedding is not needed to make an item with a Ritual of Armor.

### Ritual of Defense

This ritual creates a sorcerous defense that protects a character as an *Invulnerability* spell and will stop a *Kill* spell – even one augmented by Warlockery. After the Ritual of Defense is expended; it resets itself after 5 minutes.

The caster can choose to cast this ritual upon themselves, upon another character, or upon an item. If cast on themselves or another character there is no in-game representation of the ritual. If this ritual is cast upon an item, a temporary item card must be made to indicate the magical nature of the item. As with other rituals that create magical items, the item is indestructible so long as the ritual lasts. A Ritual of Embedding is not needed to make an item with a Ritual of Defense.

The player should call “Ritual of Defense” when they invoke this defense.

### Ritual of Greater Elemental Weapon

This ritual allows the caster to instill any weapon with the power of one of the six elements, which then allows the wielder to gain a magical and elemental Damage Bonus to the weapon.

The type of damage associated with each element and the damage bonus is:

Element	Effect
Fire	+1 Magical Fire
Water	+1 Magical Ice
Air	+1 Magical Lightning
Earth	+2 Mithril Damage
Life	+1 Magical Healing
Death	+0 Magical Body

For example, if an ordinary sword is enchanted to be an Earth Magic sword, then the wielder would call “Four Damage” when they used the weapon. If the weapon was a metal other than iron; the player should call that instead, the character would call “Four Mithril” if the weapon was mithril. Note that healing damage does not heal the target, however, undead who are effected by normal damage will take double damage.

When this ritual is successfully cast on a weapon, it becomes unbreakable. Only one of these rituals can be cast on a weapon at a time. If a second ritual is cast, it will automatically fail.

If a Ritual of Permanency is cast on a weapon enchanted with a Ritual of Greater Elemental Weapon, then the weapon will become a permanent elemental weapon. Only one Ritual of Greater Elemental Weapon can be cast on a weapon at one time. If a second ritual is upon the weapon it will automatically fail.

### Ritual of Elemental Protection I

This Ritual allows the recipient to ignore the effects of one element for 5 minutes and can be invoked any time during the Event, once per Tag Cycle, in which it was cast. The following table outlines what the character is protected from; this includes magical effects from spells:

Element	Protection
Fire	Fire Damage
Water	Ice Damage
Air	Lightning Damage
Earth	Bonds Spells, Petrification Attacks
Life	Healing Damage
Death	Death Damage

This will only protect the character from the damaging effects of the element. Special martial skills such as the Stun, Disarm, Shatter Weapon, Slay skills, etc. are not stopped by this ritual. Eldritch attacks are not stopped by this ritual. This ritual cannot be invoked as a defense to an attack.

The player should call “No Effect” when struck with the appropriate attack.

### Ritual of Feign Life

When this ritual is cast on an undead, the undead will appear to all senses as the living breathing person they were in life. The undead will even appear to bleed if struck. A *Detect Life* spell or First Aid skill will detect the undead as alive. However, if the undead is immune to a class of weapons or spells, then no effect will show. The Detect Undead skill will detect the undead under the effects of this ritual. Also note that this ritual does not grant any extra abilities to the undead. This ritual will not protect the undead from sunlight.

### Ritual of Health

This ritual charges a living character with the power of life. The effect doubles the Body Point stat of the recipient for the rest of the Event. This ritual will not double the effects of other rituals, spells, or alchemy. These new Body Points are healed normally.

Only one Ritual of Health may be cast on a character at a time, any additional castings of this ritual will automatically fail.

### Ritual of Investiture

This ritual allows a previously-invested member of a circle to invest a new member, despite the fact that the investor may not have created the circle. The caster is in effect magically sponsoring the new member into the circle. The new member can, after the ritual is complete, raise and lower the circle.

The character to be invested in the circle must give up one permanent Power Point. This Power Point has to come from the character and cannot be given by another. Should the character be de-invested or the circle they are invested in is destroyed, the character will regain their lost Power Point.



### Ritual of Permanent Magic Transfer

This ritual allows one or more willing spell casters to permanently transfer Power Points to the recipient. A character under the effects of an *Enslavement* or *Domination* spell or other mind controlling effect is not considered “willing”. This ritual functions exactly like the Transfer Magic ritual except that the Power Points are transferred permanently.

The permanent Power Point donor must be Level 5 and can only donate up to a maximum of 20% of the donor’s total Power Points. Additionally, the recipient character cannot have more Power Points than they could learn.

As with all permanent Power Point loss, the character must be completely willing. So, not only are characters under a mind controlling effect not willing, but those coerced in any manner are also not willing characters. Forcing a character with the threat of personal death or the death of another are examples of coercion.

### Ritual of Necromancy Shield

This ritual provides the recipient with a magical spell defense that will protect them from any necromantic spell or attack, including spells augmented by Warlock skills such as the Total Power skill. After the necromancy shield is invoked it is expended and it resets after 5 minutes.

This Ritual will go off against the first necromancy spell or ritual if the recipient is unconscious, or otherwise rendered unable to use a spell defense.

The caster can choose to cast this ritual upon themselves, upon another character, or upon an item. If cast on themselves or another character there is no in-game representation of the ritual. If this ritual is cast upon an item, a temporary item card must be made to indicate the magical nature of the item. As with other rituals that create magical items, the item is indestructible so long as the ritual lasts. A Ritual of Embedding is not needed to make an item with a Ritual of Necromancy Shield.

The player should call “Necromancy Shield” when they invoke this defense.

### Ritual of Raise Graveyard

When this ritual is cast, the Sorcerer will raise 150 lesser undead. The specific undead raised is up to the Plot Committee, but they will be a mix of what is listed below.

Lesser Undead	Up to...
Zombie	80%
Skeleton	60%
Ghoul	40%
Revenant	20%
Specter	10%
Wraith	10%

The undead are under the control of the caster and will remain until destroyed.

### Ritual of Remove Curse

This ritual removes all curses from one target individual or object, which must be present in the ritual.

### Ritual of Spell Shield

This ritual provides the recipient with a magical shield that can protect them from any magical spell or effect including spells augmented with Warlock abilities such as the Total Power skill, Nature Magic, Spell Singing, and sorcery rituals rank 5 or lower. After the spell shield is invoked to protect against a spell, the shield is expended; it resets itself after 5 minutes.

The caster can choose to cast this ritual upon themselves, upon another character, or upon an item. If cast on themselves or another character there is no in-game representation of the ritual. If this ritual is cast upon an item, a temporary item card must be made to indicate the magical nature of the item. As with other rituals that create magical items, the item is indestructible so long as the ritual lasts. A Ritual of Embedding is not needed to make an item with a Ritual of Spell Shield.

The player should call “Spell Shield” when they invoke this defense.

### Ritual of True Undead Control

This ritual allows the caster to control any lesser undead within a 50 foot radius and that are within Line of Sight. This radius moves with the caster. Lesser undead which are given commands will continue to follow those commands after they leave the radius of control unless directly controlled by another character. Undead within 10 feet of the caster of this ritual may not be controlled by anyone else; the ritual’s power suppresses the power of any other Necromancy spell. Should two Rituals of True Undead Control come in conflict, then the closer caster wins. Follower of the Light and Servant of Darkness skills that effect undead will override this ritual until the caster is able to re-establish control.

All undead in the area of effect are under the caster’s control as long as the undead are inside the area of effect. The caster may give any number commands during this time. Should someone else control the undead, turn the undead or new undead enter the area, the caster must re-invoke the ritual to gain control.

The effects of this ritual last till the end of the current Tag Cycle. If Ritual of Permanency is cast, then this ritual is effective all the time.

In order to use this ritual, the caster should call “Invoke Ritual of True Undead Control”.

## Rank 3 Rituals

### Ritual of Dispel Lesser Sorcery

This ritual dispels all active low magic spells – even ones augmented with Warlockery, all Nature Magic spells and all Spell Singing spells on the target character or item; or any one Ritual below 3<sup>rd</sup> Rank. Spells that create an effect and are no longer active such as undead created by the Necromancy School or ritual are not affected by this ritual.

The caster of the ritual should declare the ritual being dispelled, however if the caster fails to do so then the target, if it is able to, must choose an available ritual to be dispelled. For example, a character has a permanent Ritual of Faith Shield and a temporary Ritual of Alchemy Shield and Spell Shield. This ritual is cast upon that character, but no ritual is specified by the caster. The target player has to choose either the Alchemy or Spell Shield; they cannot choose the permanent Faith Shield as this is not a viable target of the ritual.

### Ritual of Divine Blessing

This white ritual, when cast on a character, will grant the benefits listed below. The character can only be affected by one Ritual of Divine Blessing at a time. The effects of this ritual are stackable with a Ritual of Health, but the effects are not cumulative; the Ritual of Health only doubles the character's Body Point stat and this ritual adds to the final number. This is also true for Power Points, this ritual will add the bonus after any other modifiers.

This ritual makes the following additions to the target character:

- Immunity to Fear
- Increases Body Points by +25
- Increases Power Points by +25
- Increases Strength Bonus by +1

This ritual, while cast upon a character, is focused though an item that has been blessed and imbued with Faith Points. The item must be worth at least 10 silver pieces and is not consumed in the ritual. The recipient must be wearing the item to receive the benefits of the ritual. If the item is removed and later recovered and worn, the character once more gain the benefits of the ritual as long as the duration has not expired. No other character can gain the benefits of this ritual by wearing the item.

### Ritual of Elemental Energy 2

This ritual charges the caster with the energy of a particular element. After invoking this ritual, the invoker can throw an infinite number of bursts of elemental energy. The damage and type of damage is given in the table below; the caster throws a spell packet and states the amount of damage followed by the type of damage; "Eight Fire." Only one spell packet can be thrown at a time. This damage is physical and therefore can be blocked by shields and an *Invulnerability* spell but not a *Negation* spell.

The type of damage associated with each element is:

Element	Effect
Fire	8 Normal Fire
Water	8 Normal Ice
Air	8 Normal Lightning
Earth	10 Normal Damage
Life	8 Normal Healing
Death	6 Normal Body

Note that healing damage does not heal the target, however, undead who are effected by normal damage will take double damage.

The caster can choose to cast this ritual upon themselves, upon another character, or upon an item. If cast on themselves or another character there is no in-game representation of the ritual. If this ritual is cast upon an item, a temporary item card must be made to indicate the magical nature of the item. As with other rituals that create magical items, the item is indestructible so long as the ritual lasts. A Ritual of Embedding is not needed to make an item with a Ritual of Elemental Energy 2.

If this ritual were to become permanent, it would give the caster the ability to "charge up" with elemental energy once per Event; the charge would last for 1 hour.

### Ritual of Embedding

This ritual allows a spell or ritual to be embedded within an object or item. The spells or rituals to be embedded must be cast on the item during the ritual the number of times you want the item to contain the spell. Only spells of the same school of magic can be embedded into the same item.

There is a difference between permanently embedding a ritual into an item and making that ritual permanent. The permanent Power Point cost listed in various rituals are the cost should a Ritual of Permanency be cast. To permanently embed a spell, the Ritual of Permanent Embedding is used, not this ritual. To permanently embed a ritual, the Ritual of Permanent Ritual Embedding should be used.

Also note that there is a difference between, for example, casting a Ritual of Enchantment on an item and embedding a Ritual of Enchantment into an item. The former causes a weapon to become magical. The latter causes the ritual to be stored into an item from which it can be invoked later to enchant a weapon.

**No more than four rituals, or up to ten charges of any combination of spells from the same school, may be embedded in one item.** They must all be cast into the item during one ritual. Only one Ritual of Embedding or Permanent Embedding may be cast on any one item. Additionally, you may not cast another Ritual of Embedding to "recharge" an item that does not have four rituals or ten spells in it already.

Spells cast into an item need to be declared and recorded on the item card to be either Invokable or Castable. A Ritual of Permanency does not have to be cast on this item to make it permanent. This ritual cannot be used to make other rituals permanently embedded; a Ritual of Permanent Ritual Embedding must be used instead.

The spells to be embedded can come from the caster or another character who has to be either a participant or caster in the ritual; it cannot come from an item or scroll. If two or more sorcerers are casting this ritual together, one or both of them can cast some or all of the spells into the item. The exception to this is lost magic. In order to embed a lost spell into an item, the Sorcerer casting the ritual must know the spell being embedded and must use twice the amount of Mummy Dust normally required.

Any low magic spell or spells embedded into an item must all be declared either Invokable or Castable, not some combination.

This ritual cannot be made permanent even with a Ritual of Permanency.

The item to contain the spells must be a LAIRE in-game item with a number and any value over 1 silver piece for embedded spells or rituals. If the item is made Invokable, the ritual requires double the normal amount of Mummy Dust. This is in addition to added amount needed for embedding lost spells.

### Ritual of Item Ward

When this ritual is cast on a book or container, no larger than 10 cubic feet, it becomes unbreakable, unmovable and unable to be opened when closed. When the ritual is cast the character has the option of giving the object a ward word which cannot be changed once set. The ward can be lowered, and the object opened, by speaking the ward word or the caster touching the object and willing the ward down. Once turned off, the ward will remain down so long as the object remains open. Closing the item automatically activates the Item Ward. While the object is opened, it may be moved as normal until it is closed. If the item is closed it will immediately drop to the ground.

Any item placed within the container must allow the container to close. Any pages of a book originally present when the ritual is cast are warded; any new paper or items placed inside the book are only warded when the book is closed.

If a Ritual of Permanent Ritual Embedding is cast with this ritual, and the item is neither a book nor container, then that item becomes known as a Guardian or Watcher. This item has slightly different properties; the owner may place the Watcher on a container or book of the appropriate size and invoke the ritual. The object becomes warded – along with the Watcher – as if the Ritual of Item Ward was cast upon it. The Watcher can be removed and the object opened if the ward word or original caster touches the Watcher and wills the ritual down. The Watcher can then be placed on another object and ward that book or container.

A small piece of tinsel or yellow duct tape should be placed on the container or book and the appropriate Marshal Notes must accompany the book or container. Only one Ritual of Item Ward can be cast upon the same object. You can place a book that has been warded inside a box that has been warded.

### Ritual of Lesser Attunement

This ritual makes an item attuned to the body of the user such that the item must remain on their person. The item must remain in physical contact with the user or an item in contact with the user for example, a scabbard, a pouch, a gloved hand, etc. If the attuned item is in contact with the user through another item, and that item is broken, then the attuned item immediately returns to the user. If the user is resurrected in a Healer's Circle, they will resurrect with the item in their hand.

The ritual requires the presence of the person the item is to be attuned to and a small quantity of that person's "blood." More than one person may be attuned to an item using this ritual. Any number of people may be attuned, but only specific individuals not variable groups can be attuned. All the characters to be attuned to the item must be present at the ritual.

Even if a character becomes unresurrectable, the attuned item will remain with the body. If the body is ever destroyed, then the item attunes itself to the ground at that spot. If there is another character

the item is attuned to, that character may come and take the item from either the body or the ground. At Plot's discretion, the attunement may be broken or shifted and the item brought back in-game if the player has not played that character for more than 1 year.

When this ritual is cast on an item, it becomes unbreakable. It cannot be destroyed by *Shatter*, *Blast*, *Giant Strength*, or similar skills or abilities. When the attunement wears off, the item returns to its normal status. For this ritual, both the item and the user are the targets of this ritual, and should the ritual fail and all components expended, the item and user are unaffected.

### Ritual of Minor Item Creation

This ritual allows the caster to place up to three spells of Rank 1 and no more than 3 Power Points per spell into an item. All the spells must be from the same school and can be invoked once each per Tag Cycle.

Spells cast into the item need to be declared and recorded on the item card to be either Invokable or Castable. This ritual cannot be combined with any other ritual except any Ritual of Attunement.

The spells to be embedded can come from the caster or another character who has to be either a participant or caster in the ritual; it cannot come from an item or scroll. If two or more sorcerers are casting this ritual together, one or both of them can cast some or all of the spells into the item. One or both of them can cast some or all of the spells into the item. The exception to this is lost magic. In order to embed a lost spell into an item, the Sorcerer casting the ritual must know the spell being embedded and must use twice the amount of Mummy Dust normally required.

The item to be enchanted must be worth 5 silver pieces per charge. If the item is made Invokable, the ritual requires double the normal amount of Mummy Dust. This is in addition to added amount needed for embedding lost spells.



### Ritual of Permanent Storing

This ritual allows Power Points to be permanently stored in a gem or an item which contains a gem. These Power Points may be used later by the caster or by another person. Any gems used to store Power Points must be legitimate in-game items approved by the Treasure Manager. The Power Points stored will renew at the beginning of every Tag Cycle.

When this ritual is successfully cast on a gem, it becomes unbreakable. It cannot be destroyed by *Shatter*, *Blast*, or similar spells or abilities. When the enchantment ends, the gem becomes breakable again.

If the permanent Power Points stored in the gem are used for permanent Power Point costs in any way, then the Power Points come out at a 6 for 1 ratio.

*For example, Garric wants to make a gem with 30 permanent Power Points. The gem would need to be worth at least 90 silver pieces, would cost 150 temporary Power Points, 10 permanent Power Points, and take 60 minutes to cast. Later he uses the gem to cast a Ritual of Permanency and needs 4 permanent Power Points. The gem now has 6 permanent Power Points left in it.*

A gem or item containing a gem must be worth 3 silver pieces per Power Point to be stored.

A character can become attuned to the item if they choose to during this ritual. The person to be attuned, the item they will be attuned to, and a small quantity of that person's blood must be present during the ritual. For rules concerning attunements, see the Ritual of Attunement.

No more than 25 Power Points can be stored in any one gem.

### Ritual of Undead Enhancement 1

This ritual enhances the racial abilities of the undead upon which it is cast. This is a permanent augmentation. An undead may only be enhanced by this ritual once; any subsequent castings have no additional affect.

The ritual will make the following enhancements to an undead:

- Increase Damage Resistance by one level
- Increase Body Points by +25
- Increase Strength Bonus by +1

This ritual augments the target, as such cannot be dispelled and does not count as one of the four rituals a character can have cast on themselves.

### Rank 4 Rituals

#### Ritual of Armor Enchantment

This ritual creates an enchanted suit of armor that has an increased number of Base Armor Points, i.e. not including the Real Bonus, Armor Efficiency skill, or Oils of Armor. This ritual can be cast on a complete suit of armor, increasing the value of each piece. This ritual can be cast on just one piece of armor, increasing just that one piece. Any combination of armor – leather, ring mail, chain mail, etc. – can be used in this ritual and in any combination of pieces; however, only one specific per location piece can be enchanted at a time. You could, for example, enchant a plate helm, chain mail cuirass, a right leather bracer, and soft leather leggings. However you could not put another helm or another piece of chest armor into the ritual. Only one of them will be enchanted. Since there is only one bracer, another bracer can be added.

The armor will always retain some of its protective qualities and will always have 25% of its Base Armor Points after spending 5 minutes resetting the armor after a battle. This is not stackable with the Armor Efficiency skill. Lastly, the armor will degrade at 2 Armor Points instead of the normal 3 Armor Points.

*For example, Aberle wants to enchant Dunkin's armor. He has several pieces of armor totaling 20 Armor Points. The armor is Enchantment Quality and after casting the ritual, the armor is worth 30 Armor Points and will always have at least 8 Armor Points after he rests his armor after a battle.*

The armor can be worn separately, all together, or by separate characters. The Armor Points will degrade following the above armor rules and will need to be repaired normally when they run out.

Material	Armor Bonus
Normal Armor	+25%
Enchantment Quality, Elven, or Dwarven Crafted	+50%
Mithril	+100%
Special Alloy (Adamantine, etc.)	+150%

If a character participates in the ritual, they can become attuned to all the armor pieces. For rules concerning attunements, see the Ritual of Attunement.

When this ritual is successfully cast on a piece of armor, it becomes unbreakable but **not** undamageable. It cannot be destroyed by *Shatter*, *Blast*, *Giant Strength*, or similar spells or abilities. When the enchantment wears off, the armor returns to its base metal again.

#### Ritual of Attunement

This ritual makes an item attuned to the body of the user such that the item must remain on their person. The item must remain in physical contact with the user or an item in contact with the user for example, a scabbard, a pouch, a gloved hand, etc. If the attuned item is in contact with the user through another item, and that item is broken, then the attuned item immediately returns to the user. If the user is resurrected in a Healer's Circle, they will resurrect with the item in their hand.

The ritual requires the presence of the person the item is to be attuned to and a small quantity of that person's blood. More than one person may be attuned to an item using this ritual, all of whom must be

present during the entire ritual. Any number of people may be attuned, but only specific individuals not variable groups can be attuned. The person(s) to be attuned are targets of the ritual.

Even if a character becomes unresurrectable, the attuned item will remain with the body. If the body is ever destroyed, then the item attunes itself to the ground at that spot. If there is another character the item is attuned to, that character may come and take the item from either the body or the ground. At Plot's discretion, the attunement may be broken or shifted and the item brought back in-game if the player has not played that character for more than 1 year.

When this ritual is cast on an item, it becomes unbreakable. It cannot be destroyed by *Shatter*, *Blast*, *Giant Strength*, or similar skills or abilities. When the attunement wears off, the item returns to its normal status. For this ritual, both the item and the user are the targets of this ritual, and should the ritual fail and all components expended, the item and user are unaffected.

#### Ritual of Aura of Death

When this ritual is cast, the recipient can invoke the Death Touch skill in a 10' radius. All normal defenses for the normal Death Touch skill will protect the affected characters. This may be used once per Tag Cycle.

#### Ritual of Aura of Life

When this ritual is cast, the recipient can invoke the Life skill in a 10' radius. All normal defenses for the normal Life skill will protect the affected characters. The character will not fall unconscious. This may be used once per Tag Cycle.

#### Ritual of Circle of Protection

This ritual creates a magical circle of protection preventing anything but clean air from passing through. No attacks of any kind will penetrate the circle, similarly, the Hypnosis skill, racial charms, Warlock augmented spells, any other sorcerous rituals or effects or alchemical gasses will not penetrate the circle. Extra planar travel – such as a Ritual of Leaving – either into or out of the circle is permitted. The circle is controlled by the caster who can never be de-invested from the circle. Any character that has been invested in the circle can use the Ritual of Investiture to invest another character.

The Circle can encompass an entire structure and stands 10 feet from the structure or can be free-standing, either way the circle cannot be larger than 100 yard radius. The boundary of a circle cannot intersect an object. A circle is in fact a closed cylinder, with top and bottom, at least 10 feet high and no more than 100 feet high; it is not possible to bypass its protection by going through the floor or ceiling.

While casting this ritual, the caster may invest other participants if they so desire. The invested characters must be present, count as participants, and must still spend 1 permanent Power Point.

The circle can be raised and lowered only by the caster or other invested members. The player should call loudly enough to be heard "Circle Down" or "Circle Up". This is an out-of-game comment. Placing any person or object on a lowered circle will not prevent the circle from rising. Any person must choose to either fall into or out of the circle. Any item falls out of the circle by default. The character must be within Line of Sight of the circle to control it. The character must be in-game and present to control the circle.

There are sometimes situations where two or more people invested in a circle may have a conflict of wills over whether the circle is raised or lowered. To resolve such a conflict, total the unspent Power Points on each side of the conflict; the side with greatest number of

unspent points wins. If both sides have exactly the same number of unspent Power Points, then the status quo prevails: if the circle was up it stays up, if it was down it stays down.

The caster of the ritual is responsible for providing a garland, glow rope, or other out-of-game representation of the Circle of Protection.

Casting the Ritual of Permanency upon a circle of protection requires the full, 4 charge, version of permanency to be cast.

#### Ritual of Death

This ritual turns a character into a Death Knight, Death Mage, or Death Assassin, a skeletal greater undead creature. The Death Knight, Death Mage, or Death Assassin is under the control of the caster of the ritual.

-The player of the character who died must now play the newly-created undead creature. The greater undead follows all the normal rules for their Death Count, however should they die, their body turns to dust. The player takes one Death on their character card and may now go to the Healer's Circle to have their spirit resurrected.

Unlike the undead creation spells of the Necromancy school, the undead created by this ritual can last longer than one Event. The player of the undead character is therefore obligated to play the creature until it is destroyed, or until two months, not two events have passed since the ritual was cast. Only when the undead creature is gone can the player's character be resurrected.

This ritual can be cast on a dead body or on a living character by delivering a Killing Blow at the end of the ritual. This ritual requires the body of the character to be turned into a Death Knight, Death Mage, or Death Assassin, the body of a different character *cannot* be substituted. Should the ritual fail, and all components consumed, then the dead body is destroyed. If a living character was the target of this ritual, then there is no added effect and the character should continue their Death Count normally.

Death Knight, Death Mage, or Death Assassin last until destroyed or two months – the month the ritual was cast and the following month – if the target character can resurrect. If the character is un-resurrectable, then this ritual is permanent until the undead is destroyed.

### Ritual of Domination

This ritual dominates a character as per the *Dominate* spell. This ritual lasts until the end of the current event and cannot be dispelled with a low magic spell. This ritual is not stopped by any low magic spell defense and persists even if the person is resurrected.

While under the affects of this ritual, the character may use an Iron Will skill to regain their own will for 10 minutes, after which time they are once more under the affects of this ritual.

This ritual cannot be made permanent. This ritual over rides any Charm School spell or skill. Greater charms such as Possession, Vampiric Charm, Demonic Charm, or Draconic Charm supersede this ritual. This ritual has no effect on characters immune to charms or Domination.

### Ritual of Elemental Protection II

This ritual allows the recipient to ignore the effects of one element for 1 hour and can be invoked any time during the Event in which it was cast. The following table outlines what the character is protected from, this includes magical effects from spells:

Element	Protection
Fire	Fire Damage
Water	Ice Damage, Water Breathing
Air	Lightning Damage
Earth	Bonds Spells, Petrification Attacks
Life	Healing Damage
Death	Death Damage

This will protect the character from the damaging effects of the element. Special martial skills augmented by that element such as the Stun, Disarm, Shatter Weapon, Slay skills, etc. are stopped by this ritual. Eldritch attacks are not stopped by this ritual. This ritual cannot be invoked as a defense to an attack.

### Ritual of Enchantment

This ritual creates an enchanted weapon that does magical damage; the weapon has a bonus that depends on the type of material used in creating the weapon:

Material	Damage Bonus
Normal weapon	+0
Enchantment Quality, Elven, or Dwarven Crafted	+1
Mithril	+2
Special Alloy (Adamantine, etc.)	+3
Gem Weapons	+5

While it cannot be used as a weapon, a dissection dagger can be enchanted. It allows the user to dissect creatures with Damage Resistance: Magic.

If a character participates in the ritual, they can become attuned to the weapon. For rules concerning attunements, see the Ritual of Attunement. This ritual is not combinable with Rituals of Elemental Weapon and Greater Elemental Weapon, nor can this ritual be stacked with itself or any other type on weapon crafting augment. Once a weapon has one of these rituals upon it, all subsequent rituals cast automatically fail.

When this ritual is successfully cast on a weapon, it becomes unbreakable. It cannot be destroyed by *Shatter*, *Blast*, *Giant*

*Strength*, or similar spells or abilities. When the enchantment wears off, the weapon becomes breakable again.

### Ritual of Item Creation

This ritual allows the caster to place two spells of Rank 3 or lower from the same school of magic and each spell no more than 12 Power Points into a piece of jewelry. Each spell can be invoked once per Tag Cycle.

Spells cast into an item need to be declared and recorded on the item card to be either Invokable or Castable. This ritual cannot be combined with any other ritual except any Ritual of Attunement.

The spells to be embedded can come from the caster or another character who has to be either a participant or caster in the ritual; it cannot come from an item or scroll. If two or more sorcerers are casting this ritual together, one or both of them can cast some or all of the spells into the item. The exception to this is lost magic. In order to embed a lost spell into an item, the Sorcerer casting the ritual must know the spell being embedded and must use twice the amount of Mummy Dust normally required.

A character can become attuned to the item if they choose to during this ritual. The person to be attuned, the item they will be attuned to, and a small quantity of that person's blood must be present during the ritual. For rules concerning attunements, see the Ritual of Attunement.

The item to be enchanted must be worth 20 silver pieces. If the item is made Invokable, the ritual requires double the normal amount of Mummy Dust. This is in addition to added amount needed for embedding lost spells.

### Ritual of Protection from Sunlight

This ritual is cast upon an undead character to protect them from the effects of sunlight. This ritual cannot be stacked with itself.

### Ritual of Re-Attunement

This ritual will shift the target of an active attunement ritual to a new target character of the casters choosing. Both the current target character and new target's physical bodies must be present for the ritual to work. This ritual will only work if both characters are willing or unresurrectable.

An item can only be re-attuned to a single character with this ritual. If other characters were originally attuned to the item, then they are still attuned after the ritual is completed. In essence, one character is assuming the attunement of another.

The duration of this ritual is the remainder of the duration of the original attunement. If the original attunement was permanent, this one will be also.

Once an attunement has been shifted, it follows the rules for the Ritual of Attunement with the exceptions stated above.

## Ritual of Undead Enhancement 2

This ritual enhances the racial abilities of the undead upon which it is cast. This is a permanent augmentation. An undead may only be enhanced by this ritual once; any subsequent castings have no additional affect. This ritual can only be cast upon an undead character that has already been augmented by the Ritual of Undead Enhancement 1.

The ritual will make the following enhancements to an undead:

- Increase Damage Resistance by one additional level
- Increase Body Points by +25
- Increase Strength Bonus by +1
- Increase Power Points by +25
- One more use of their special primary ability. For example, Death Assassins get one more Assassinate, Death Knights get one more Slay, and Death Mages get +20 Power Points, etc.

This ritual augments the target, as such cannot be dispelled and does not count as one of the four rituals a character can have cast on themselves.

## Ritual of Wight Creation

This ritual turns a body that is dead or on the brink of death into a Wight, a incorporeal creature that can only be affected by Mithril or Magical weapons. The Wight is under the control of the caster of this Ritual. The Wight is fearsome in its ability to steal a skill from a defeated (immobile, unconscious, sleeping, dying) foe. If the Wight is destroyed, then it leaves behind a Wight Stone that contains the stolen skill. This skill may be used by anyone possessing the stone (with the exception of Faith skills in the hands of a non or other Faith character). If the character who lost the skill acquires the Wight Stone that contains his skill, he can simply reabsorb the skill by willing it back.

Unlike the undead-creation spells of the Necromancy school, the undead created by this ritual can last longer than one event. The player of the undead character is therefore obligated to play the creature until it is destroyed, or until two months (not two events) have passed since the ritual was cast. Only when the undead creature is gone can the player's character be resurrected.

A Wight is a Greater Undead. White Ritual Powder may not be substituted in this Ritual.

## Rank 5 Rituals

### Ritual of Absolute Healing

This ritual heals the target character, whose body or heart must be present, of ALL ailments. The character is resurrected if dead, automatically drawing a white marble but otherwise follows all normal rules for resurrections. If the character has only a red marble left, this ritual will not resurrect the character. This ritual will not resurrect a character that is over 20<sup>th</sup> Level or is un-resurrectable. The ritual also restores the character to their full Body Points including any lost permanently due to magic effects but not Golem Creation, removes all curses, heals all limbs, restores all senses even to someone born that way, cures insanity both natural and magical, and cures all diseases affecting the character. This ritual has no effect on an undead. This ritual will not return Build Points or skills lost by any means.

### Ritual of Break Attunement

This ritual will destroy any one active attunement on an item on a target character's body. The target character must be present for the ritual to work. This ritual will only work if the target character is willing or unresurrectable.

If any other characters share in the attunement being broken, then they also lose their attunement once the ritual is cast.

### Ritual of Dispel Sorcery

This ritual dispels all active low magic spells – even ones augmented with Warlockery, all Nature Magic spells and all Spell Singing spells on the target character or item; or any one Ritual below Rank 5. Rituals that have been permanenced with Ritual of Permanency cannot be dispelled with this ritual. Spells that create an effect and are no longer active such as undead created by the Necromancy School or ritual are not affected by this ritual.

The caster of the ritual should declare the ritual being dispelled, however if the caster fails to do so then the target, if it is able to, must chose an available ritual to be dispelled. For example, a character has a permanent Ritual of Faith Shield and a temporary Ritual of Alchemy Shield and Spell Shield. This ritual is cast upon that character, but no ritual is specified by the caster. The target player has to choose either the Alchemy or Spell Shield; they cannot choose the permanent Faith Shield as this is not a viable target of the ritual.



### Ritual of Elemental Energy 3

This ritual charges the caster with the energy of a particular element. After performing this ritual, the caster can throw an infinite number of bursts of elemental energy. Each burst of energy causes elemental damage according to the table below; the caster throws a spell packet and states the amount of damage followed by the type of damage; for example, “Sixteen Fire.” Only one spell packet can be thrown at a time. This damage is physical and therefore can be blocked by shields and an Invulnerability Spell, but not a Negation Spell.

The type of damage associated with each element is:

Element	Effect
Fire	16 Normal Fire
Water	16 Normal Ice
Air	16 Normal Lightning
Earth	20 Normal Damage
Life	16 Normal Healing
Death	12 Normal Body

Note that healing damage does not heal the target, however, undead who are effected by normal damage will take double damage.

The caster can choose to cast this ritual upon themselves, upon another character, or upon an item. If cast on themselves or another character there is no in-game representation of the ritual. If this ritual is cast upon an item, a temporary item card must be made to indicate the magical nature of the item. As with other rituals that create magical items, the item is indestructible so long as the ritual lasts. A Ritual of Embedding is not needed to make an item with a Ritual of Elemental Energy 3.

If this ritual were to become permanent, it would give the caster the ability to “charge up” with elemental energy once per Event; the charge would last for 1 hour.

### Ritual of Elemental Summoning

This ritual allows the caster to summon a level five Fire, Water, Air, Earth, Life or Death Elemental who will perform any number of tasks for the caster. Any task not completed in the 90 minute duration will be left undone and the elemental will return to its home plane. If the Ritual of Elemental Summoning is made permanent, then it may be summoned once per Event by the caster.

A specific elemental can be summoned if the caster has its essence. The control the caster has over the elemental is similar to the control over an undead – the elemental knows it has been summoned and is under the casters control and while it must obey the caster it must only obey the letter of the order.

Note: A Plot Marshal must be informed before this ritual is performed so that they may get an NPC to play the elemental.

### Ritual of Faith Shield

This ritual protects the character from the effects of faith skills, spells and abilities from the Follower of the Light, Druid and Servant of Darkness skill lists. Additionally, one charge of this ritual will stop the effects of a White or Dark ritual, however, the character must be conscious to invoke this ritual. For purposes of determining if the skill is used, consider this ritual the same as an *Invulnerability* spell; so Death Touch skill is stopped and the skill is used, but a Destroy Undead skill is blocked and the skill is not used.

After the faith shield is invoked to protect against an attack, the shield is expended and resets itself after 5 minutes. This ritual has three charges and each one takes 5 minutes to reset. For example, if a character uses one charge then 3 minutes later uses another, the first charge will reset 2 minutes later and next one 3 minutes later.

This ritual will not block other spells or skills – Slay skill, *Inferno* spell, etc – from a follower of a faith, but will stop an attack augmented with their power. For example, a Dark Paladin who charges their weapon with their Wounding Pool, or a Druid using their Elemental Pool to swing their element can have the attack stopped by this ritual.

The caster can choose to cast this ritual upon themselves, upon another character, or upon an item. If cast on themselves or another character there is no in-game representation of the ritual. If this ritual is cast upon an item, a temporary item card must be made to indicate the magical nature of the item. As with other rituals that create magical items, the item is indestructible so long as the ritual lasts. A Ritual of Embedding is not needed to make an item with a Ritual of Faith Shield.

The player should call “Faith Shield” when they invoke this defense.

### Ritual of Leaving

With this ritual the caster creates a magical 5 foot wide by 10 foot high gate. The gate leads to the location where the ritual was originally cast. This ritual can be placed upon the caster, another character, or cast into an item.

The gate opens when the caster calls upon the power of the ritual (invokes the ritual). The caster must spend 15 seconds laying down a 5 foot long piece of garland indicating the opening of the portal. The character can be interrupted in the same ways the casting of a spell is interrupted. If the character is interrupted, the portal fails to open and the charge is not expended.

The gate may be opened anywhere the caster chooses with the following limitations: the gate must be vertical and the size and shape of the gate will conform to the available space. The gate automatically closes when the caster has passed through it, therefore the caster cannot be followed into the gate. Up to two other characters – so long as they can fit through the gate – or up to 600 lbs of material may go through the gate before the caster. Players should put on white headbands and go to the location where the ritual was cast immediately.

The caster may choose to close the gate at any time. Regardless, the gate will close in 30 minutes if the caster does not go through or chooses to close it. If the caster is still in their Death Count, they can be dragged through the gate. If three people go through before the caster, then the gate closes. The gate is one way and has only one face. Once the caster invokes the ritual, that side is the doorway; the opposite side is impassible and appears as a solid glowing wall. Any character attempting to pass through the wrong side of the portal will simply be stopped as if they tried to pass through a solid wall.

If this ritual is made permanent, then the caster can invoke the ritual once per Tag Cycle.

### Ritual of Permanency

This ritual makes another ritual permanent. This ritual has no effect on those rituals that have a duration of Instant or Permanent, or that specify in the ritual's description that they cannot be made permanent.

A single Ritual of Permanency can make up to four rituals permanent on a single character or item. For each ritual made permanent more of certain components are required. These components are listed as "x" doses per ritual in the following component chart. For example, if an item has a Ritual Greater Elemental Weapon- Fire, a Ritual of Attunement, Ritual of Spell Shield and Ritual of Defense on it, only one Ritual of Permanency is necessary to make all of them permanent.

Once rituals have been made permanent on an item, no other permanency rituals may be cast on that item.

Casting a Ritual of Permanency costs not only the permanent Power Points for this ritual but the permanent Power Points listed in each individual ritual. For the above example, the caster would have to expend: 3 for the Permanency, 5 for Greater Elemental Weapon, 5 for the Spell Shield, 5 for the Defense and 4 for the Attunement, a total of 22 permanent Power Points.

**This ritual can not be parentally embedded with the Ritual of Permanent Ritual Embedding.**

A character can become attuned to the item if they choose to during this ritual. The person to be attuned, the item they will be attuned to, and a small quantity of that person's blood must be present during the ritual. For rules concerning attunements, see the Ritual of Attunement.

The item that will have the rituals permanencied must already have the rituals cast and must be worth at least 10 silver pieces per ritual.

### Ritual of Permanent Embedding

This ritual allows a spell(s) to be permanently embedded within an object or item. The spell(s) to be embedded must be cast on the item during the ritual the number of times you want the item to contain the spell. Only spells of the same school of magic can be embedded into the same item.

**The item may have no more than ten charges. No more than five charges of one spell may be embedded in the item.** Any combination of spells from the same school may be embedded in one item. They must all be cast into the item during one ritual. Only one Ritual of Embedding or Permanent Embedding may be cast on any one item.

Spells cast into an item need to be declared and recorded on the item card to be either Invokable or Castable. A Ritual of Permanency does not have to be cast on this item to make it permanent. This ritual cannot be used to make other rituals permanently embedded; a Ritual of Permanent Ritual Embedding must be used instead.

The spells to be embedded can come from the caster or another character who has to be either a participant or caster in the ritual; it cannot come from an item or scroll. If two or more sorcerers are casting this ritual together, one or both of them can cast some or all of the spells into the item. The exception to this is lost magic. In order to embed a lost spell into an item, the Sorcerer casting the ritual must know the spell being embedded and must use twice the amount of Mummy Dust normally required.

A character can become attuned to the item if they choose to during this ritual. The person to be attuned, the item they will be attuned to, and a small quantity of that person's blood must be present during the ritual. For rules concerning attunements, see the Ritual of Attunement.

The item that will have the spells permanencied must be worth at least 2.5 silver pieces per Power Point in all the spells. For example, an item with five Life spells would have to be worth 150 silver pieces. If the item is made Invokable, the ritual requires double the normal amount of Mummy Dust. This is in addition to added amount needed for embedding lost spells.

### Ritual of Obliteration

This ritual tears the soul from the body and sends it into the void forever. The process is remarkably painful to the victim and should be roleplayed accordingly. All of the character's marbles become black and they are permanently un-resurrectable. The character is unable to ever be turned into an undead of any type by any means.

While the ritual is being cast, the ritual holds the target character in place and they cannot move until the ritual is ended. If the ritual fails or is interrupted, the character is free to act and suffers no ill effects.

This ritual cannot be embedded with Ritual of Embedding or Ritual of Permanent Ritual Embedding.

### Ritual of Undead Enhancement 3

This ritual enhances the racial abilities of the undead upon which it is cast. This is a permanent augmentation. An undead may only be enhanced by this ritual once; any subsequent castings have no additional affect. This ritual can only be cast upon an undead character that has already been augmented by the Ritual of Undead Enhancement 3.

The ritual will make the following enhancements to an undead:

- Increase the Damage Resistance by one additional level with a maximum of Damage Resistance: Magic
- Increase the Body Points by +25
- Increase the Strength Bonus by +1
- Increase the Power Points by +25
- Increases the number of Resist ability by one or give the undead one use of the Resist ability
- One more use of their special primary ability. For example, Death Assassins get one more Assassinate, Death Knights get one more Slay, and Death Mages get +20 Power Points, etc

This ritual augments the target, as such cannot be dispelled and does not count as one of the four rituals a character can have cast on themselves.

## Rank 6 Rituals

### Ritual of Dwarven Rune Carving

This ritual will enchant a weapon with various Dwarven runes. Each rune has a different effect listed below. This ritual must be cast upon the weapon at the time of creation and the weapon needs to be Enchantment Quality or better. The casting time listed below is in addition to the crafting time for the weapon. No more than four runes may be placed on a single weapon.

When this ritual is successfully cast on a weapon, it becomes unbreakable. It cannot be destroyed by *Shatter*, *Blast*, *Giant Strength*, or similar spells or abilities. Should the enchantment end, the weapon will return to its base properties.

### Ritual of Greater Attunement

This ritual makes an item attuned to a group of users such that the item must remain on their person. The item must remain in physical contact with one of the users or an item in contact with the user for example, a scabbard, a pouch, a gloved hand, etc. If the attuned item is in contact with a user through another item, and that item is broken, then the attuned item immediately returns to the user. If the user is resurrected, they will resurrect with the item in their hand.

A group for this ritual is defined as any discernable and identifiable group or family of people. Examples of acceptable groups are: The Dukes of Avalon, The Nobles of Avalon, The Knight of Avalon, The Members of the Healer's Guild, The Doomwalkers, The Knights of Dunderdron or even the Citizens of Avalon. The group can be of any number.

While the item is attuned to one member of the group another member may not take the item away, unless that member is at the Brink of Death. In order to pass the item from one character to another character in the group, both characters must be willing. If the character holding the item dies, one of the following can happen. The character can take the item with them and resurrect, or the item will immediately go to the nearest other member of the group that is within line of sight of the character, or if no other member of the group is present, the item will embed itself into the ground or nearest object and remain there unmovable until a suitable member comes by to claim it.

Any member of a group that is removed from that group by a character or agency with the authority to do so immediately loses the item they are attuned to. The item will go to the person of authority if they are in line of sight or to the ground or nearest object if that person is not present. For example, the Duke of Avalon declares one of his nobles – who has an item attuned to the Nobles of Avalon – stripped of his titles. The Duke has the authority to remove the noble's title and the item will either go to the Duke if he is present or to the ground if he is not. Another example, a sword is attuned to any Follower of the Light, at one point the current barer of the sword falls from grace. The sword will drop to the ground, since the High Lord – the agency with the authority to do so – has removed them from the group and they obviously cannot bear the weapon.

It is possible to make a group of one, "Myself and any one I designate." The character would be able to pass the item off to anyone they want so long as both are willing. There is one caveat to this type of attunement. The character who now holds the sword is the "Myself" in the description and can pass the item off to anyone they want and the original character is no longer in the group and cannot take the item back unless they are willingly given it by the

current barer. The caster of this particular attunement is always considered to be part of the group.

The ritual requires the presence of a person from the group the item is to be attuned to and a small quantity of that person's blood.

Unlike other types of attunements, if a character dies and there are no other living members of the group, the item will sit and wait until such time as a character meeting the qualifications comes and claims the item.

When this ritual is cast on an item, it becomes unbreakable. It cannot be destroyed by *Shatter*, *Blast*, *Giant Strength*, or similar skills or abilities. When the attunement wears off, the item returns to its normal status. For this ritual, both the item and the user are the targets of this ritual, and should the ritual fail and all components expended, the item and user are unaffected.

### Ritual of Greater Defense

This ritual creates a sorcerous defense that protects a character as an *Invulnerability* spell and will stop a *Kill* spell – even one augmented by Warlockery. After the Ritual of Greater Defense is expended; it resets itself after 5 minutes. This ritual has three charges and each one takes 5 minutes to reset. For example, if a character uses one charge then 3 minutes later uses another, the first ritual will reset in 2 minutes and next one in 3 minutes.

The caster can choose to cast this ritual upon themselves, upon another character, or upon an item. If cast on themselves or another character there is no in-game representation of the ritual. If this ritual is cast upon an item, a temporary item card must be made to indicate the magical nature of the item. As with other rituals that create magical items, the item is indestructible so long as the ritual lasts. A Ritual of Embedding is not needed to make an item with a Ritual of Greater Defense.

### Ritual of Greater Spell Shield

This ritual provides the recipient with a magical shield that can protect them from any magical spell (including spells augmented with Warlock abilities such as Total Power). After the spell shield is invoked to protect against a spell, the shield is expended and resets itself after 5 minutes. This ritual has three charges and each one takes 5 minutes to reset. For example, if a character uses one charge then 3 minutes later uses another, the first ritual will reset in 2 minutes and next one in 3 minutes.

The caster can choose to cast this ritual upon themselves, upon another character, or upon an item. If cast on themselves or another character there is no in-game representation of the ritual. If this ritual is cast upon an item, a temporary item card must be made to indicate the magical nature of the item. As with other rituals that create magical items, the item is indestructible so long as the ritual lasts. A Ritual of Embedding is not needed to make an item with a Ritual of Greater Spell Shield.

### Ritual of Greater True Undead Control

This ritual allows the caster to control any undead – lesser or greater – within a 50 foot radius or that are within line of sight. This radius moves with the caster. Undead which are given commands will continue to follow those commands after they leave the radius of control unless directly controlled by another character. Undead within 10 feet of the caster of this ritual may not be controlled by anyone else; the ritual's power suppresses the power of any other Necromancy spell. Should two Rituals of True Undead Control come in conflict, then the closer caster wins. Follower of the Light and

Servant of Darkness skills that effect undead will override this ritual until the caster is able to re-establish control.

In order to use this ritual, the caster should call “Invoke Ritual of Greater True Undead Control”. All undead in the area of effect are under the caster’s control as long as the undead are inside the area of effect. The caster may give any number commands during this time. Should someone else control the undead, turn the undead or new undead enter the area, the caster must re-invoke the ritual to gain control.

### **Ritual of Dragon Hide**

This ritual gives the character Damage Resistance: Silver and a 8 Threshold for 1 hour once ever Tag Cycle. The character can invoke the ritual anytime during the Tag Cycle. If this ritual is cast upon an item then the ritual has a duration of 3 Events, otherwise the ritual is permanent once cast.

The caster can choose to cast this ritual upon themselves, upon another character, or upon an item. If cast on themselves or another character there is no in-game representation of the ritual. If this ritual is cast upon an item, a temporary item card must be made to indicate the magical nature of the item. As with other rituals that create magical items, the item is indestructible so long as the ritual lasts. A Ritual of Embedding is not needed to make an item with a Ritual of Dragon Hide.

### **Ritual of Strength**

This ritual permanently augments the target character with a +3 Strength Bonus. If the ritual caster is the target of this ritual, it has a duration of Permanent. If this ritual is cast upon another character or an item then the ritual has a duration of 3 Events. This ritual is not stackable with itself.

The caster can choose to cast this ritual upon themselves, upon another character, or upon an item. If cast on themselves or another character there is no in-game representation of the ritual. If this ritual is cast upon an item, a temporary item card must be made to indicate the magical nature of the item. As with other rituals that create magical items, the item is indestructible so long as the ritual lasts. A Ritual of Embedding is not needed to make an item with a Ritual of Strength.



## Spell Singer Advanced Career

Below is the list of skills available to players who wish to play a

Spell Singing Skill List					
Skill	Cost	Duration	Prerequisite Skill	Purchase	Tagged
Spell Singer	3	Constant	Literacy	Once	No
Spell Singing Points	1.5 SSP for 1 BP		Spell Singer	Multi	Yes
Spell Singing	4/4/4/4/4		Spell Singer, <i>Special</i>	Multi	No
Echo	6	10 Min	Spell Singing Rank 3	Multi	Yes
Extend Spell Song	4	While Sung	Spell Singing Rank 4	Once	No

Spell Singer. For a full description of the skill, see Chapter 5.

### Special Notes for the Spell Singing Skill List

- The prerequisite for Spell Singing Rank 1 is Spell Singer. For each subsequent Rank of Spell Singing, the prerequisite is the previous rank. Therefore, Spell Singing Rank 5 has a prerequisite of Spell Singing Rank 4. In addition, the character must also have the appropriate number of Spell Singing Points, much like low magic.
- There are a maximum of five ranks for Spell Singing that a character can purchase, each costing 4 Build Points.



## The Spell Singer

Spell Singing is an arcane mystical art. It draws its power from the tension between Law and Chaos – the constant pull and opposition of these two universal forces and the universal harmony created by this dance of the universe. While not exactly a high magic in the way Sorcery and Warlockery are – for it does not draw its power from the same source as low magic – it still requires its practitioners to understand arcane concepts necessary to wield this

magic. The power behind Spell Singing is magic, but not from the same source that other arcane casters draw upon.

The Spell Singers themselves are creatures of balance. They must maintain an inner balance between the universal and divine powers of the universe. This prevents them from “picking a side” and therefore cannot become – and subsequently, cannot learn skills from – Followers of the Light, Druids, Servants of Darkness, Sorcerers or Warlocks. They can live their lives as lawfully or chaotically, good or wickedly as they wish so long as they do not pledge their lives to these sides and do not learn any of the skills off these Advanced Career skill lists.

In times past, the Spell Singer has been the messenger of the Lorelei, their voice amongst the mortal races; fulfilling their masters desire to maintain the balance between good and evil in their eternal struggle against one another. The Lorelei have lost their hold over this magic and it is now up to mortals alone to govern its use and teaching.

## Spell Singing Rules

Below are some of the special rules governing Spell Singing and Spell Songs.

### Buying Spell Singing

In order to purchase a rank of Spell Singing, the character must have a certain number of Spell Singing Points indicated by the table below:

Rank	Character Level	Spell Singing Points
1	5 <sup>th</sup>	3
2	7 <sup>th</sup>	25
3	9 <sup>th</sup>	50
4	11 <sup>th</sup>	75
5	13 <sup>th</sup>	100

Note that the Spell Singer skill gives the character 3 Spell Singing Points, thereby satisfying the prerequisite for Spell Singing Rank 1.

When a character purchases a rank of Spell Singing, they do not automatically gain all the knowledge of all the songs in that rank, rather, the character must be taught each song individually. The teacher would then sign the character’s songbook indicating they have taught the character that song and the player needs then have the song approved and signed off by a Plot Marshal.

### Using Spell Singing

The harmony of balance sings to each person uniquely, so each song is unique to each Spell Singer. Every character that learns Spell Singing must create a song for each of their spells. While the effects of these spells are the same for each character, the character will personalize it for themselves. A Spell Singer can teach and share another Spell Singer one of their individualized songs from their song book. The character does not need the Teach skill and needs to sign the Spell Singer's song book to verify they have taught them the song. If the player wants to create an individualized song for their character, they need to work with a Spell Singer teacher, and have their new song approved by the teacher and a Magic Marshal.

The length of the song is determined by its rank: fifteen syllables for a Rank 1 song and an additional five syllables for each additional rank. Therefore, a Rank 5 song would have thirty five syllables. A song can be longer than this, but must meet these minimum requirements. The song should be descriptive of its effects and players hearing the song should be readily able to know what the song does. These songs must be approved by Magic Marshal before they are used. The player should call the effect at the end of the song indicating not only the effect but also the completion of the song.

All Spell Singing spells take effect at the end of the song. Some songs must be continuously sung in order to maintain the effect. Should the Spell Singer be forced to stop singing or take any damage when casting or while maintaining the effect, the spell ends. The Spell Singer may move, fight, take or use offensive or defensive actions or skills while maintaining their songs. The player may stop singing to call out-of-game effects or invoke spells, call martial defenses, or use abilities that do not require an in-game verbal. However, the Spell Singer must sing enough of their song so it is clear to everyone they are still singing a song.

Spell Songs will not bypass wards or circles or affect a character protected by a *Magic Sanctuary* or *Imprisonment* spell. Further, the Spell Singer cannot affect anyone else while inside a *Magic Sanctuary* spell or anyone outside a ward or circle they are in.

All Spell Songs affect their targets without the need to hit them with a spell packet. The Spell Singer needs an Unobstructed Line of Sight to affect their target. Additionally, the character needs to be able to see their target when they start and finish their song and the target must be able to hear the song. If a character is running past some trees while the song is sung, they are still affected by the spell, but should the character run behind a building, out of sight, or behind some semi-transparent obstacle, the song fails and the Spell Singing Points are still expended.



The target player must be able to hear the song, if the character is deaf – either naturally or because they have caused themselves to be deaf – the song still takes effect. Deafness is not a defense. If the player fails to hear the song because their attention is otherwise occupied elsewhere they are still affected by the song, however, if the player is far enough away or the Spell Singer not loud enough to reach the player the song fails. As a general rule, if there is someone else near the target that heard the song, the spell will take affect.



Spell Singing is a magical spell effect; therefore defenses that stop spells – *Negation*, *Spell Shield*, *Outlander Resist*, etc. – will defend the character against these spells. In the case of *Reflection* the song is stopped but not reflected back to the caster and for *Absorption* the song is stopped, but an *Absorption* does not gain the character any Spell Singing Points from the spell, even if they are themselves a Spell Singer. A character may use the Dodge skill to stop a Spell Song. Additionally, a character **cannot** use the Redirect Spell skill to redirect or stop a spell song.

The *Dispel Magic* and *Sever Magic* spells work on Spell Singing same as with low magic spells. See the description of these spells in Chapter 3 in the Thaumaturgy School.

### The Songbook

Each Spell Singer must maintain a songbook. This acts as a focus for their ability to sing their songs. The character must always have their songbook on their person, for without it, they will be unable to use their magic. Though the character may have as many songbooks as they wish, they all must be in-game – even if the Spell Singer is an NPC – and contain all the songs the character will use, and the character can only sing the songs in their book. While the character may refer to the book in-game to sing their songs, they do not have to. The spell book must be at least 3 inches by 5 inches.

### Losing the Song

Should a character with Spell Singing skills ever learn skills of the proscribed Advanced Career Skill Lists, they can no longer use any of their songs until they remove the knowledge and put themselves back into balance. They are not able to re-spend the build and the skills and corresponding Body Points remain on their card.

## Spell Songs

Below is the list of spells available in each rank of Spell Singing.

### 1<sup>st</sup> Rank Spell Songs

#### **Will'o'Wisp** **Duration:** *Special*

0 Spell Singing Points

This song summons a small, non-combative lesser Will'o'Wisp that will help to light the way for the singer. Combat of any kind near the Will'o'Wisp will frighten it away. Similarly, the Will'o'Wisp will not fly away from the singer to investigate anything. The Will'o'Wisp cannot speak or communicate with anyone in any way and will not go with anyone else.

To represent the light shed by the Will'o'Wisp, the singer should use a small flash light.

#### **Feat of Heroes** **Duration:** Latent

2 Spell Singing Points

When invoked, this spell grants the character a temporary +3 Strength Bonus, Non-Combinable allowing the character to add +3 to the weapon damage of their next attack, or to perform one act of giant strength for no longer than 15 seconds. If the character normally calls "Two Damage" when they hit, if they invoke a *Feat of Heroes* they would call "Five Damage". If the character fails to hit, they do not use up the *Feat of Heroes* spell.

This song can be combined with a normal *Giant Strength* spell and other Strength Bonuses.

The player must call "Feat of Heroes" when invoking this spell.

#### **Heal** **Duration:** Instant

1 Spell Singing Point per 2 Body Points,  
Variable

By means of this song the Spell Singer is able to heal a character that has lost Body Points, is Bleeding to Death, or Unconscious. It has no effect on a character that is Mortally Wounded or on the Brink of Death. The Spell Singer spends 1 Spell Singing Point per 2 Body Points of healing and can spend as many Spell Singing Points as they wish up to the current number they have.

Note, this spell is not from the element of life and will heal undead, demons, elementals, and even Golems.

#### **Confusion** **Duration:** While Sung

3 Spell Singing Points

One character targeted by this charm song will become confused and disoriented while the Spell Singer continues to sing their song. The target may not do anything except stagger around for the duration of this song. They may not fight, flee, cast spells, call latent spell defenses or invoke magic items. This effect ends if the target character takes any damage or if the caster stops singing or is interrupted.

#### **Inspire** **Duration:** Latent, 10 Minutes

3 Spell Singing Points

This song will give the recipient a +1 Damage Bonus for 10 minutes. This song is latent and can be invoked any time until the end of the current Event.

### 2<sup>nd</sup> Rank Spell Songs

#### **Injure** **Duration:** Instant

1 Spell Singing Point per 2 Body Points,  
Variable

This song causes 2 points of direct, magical body damage for every 1 Spell Singing Point expended. This damage affects all characters, even undead.

The singer can spend as many Spell Singing Points they wish up to their current number. This song cannot be used to deliver a Killing Blow.

#### **Wake** **Duration:** Instant

3 Spell Singing Points

By means of this song, the Spell Singer can awaken a character that is asleep or Unconscious. This song will work on a character who is sleeping due to a spell, *Sleep Poison* or *Dust of Sleep* or who has been rendered Unconscious by a Waylay. In the later case, the character must have at least 1 Body Point to wake up. If the character is at zero or negative Body Points, this spell will have no affect.

#### **Vocalize** **Duration:** Latent or Instant

3 Spell Singing Points

This song can be cast upon a person to protect them from any attack that would affect their ability to speak, for example a *Silent and Mute* spell or a *Silence Poison*. This song will last until invoked or until the end of the current Event.

This song can also be used to cure a person who is unable to speak whether they are under the affects of some magical spell or alchemy or are naturally mute. In the latter case, a Plot Marshal will determine if the song works.

#### **Repulse** **Duration:** While Sung and Concentrating

4 Spell Singing Points

This song will repel one character back 10 feet away from the Spell Singer. As long as the Spell Singer continues to sing, the target cannot approach within 10 feet of the singer. The target cannot push the caster away from them. The target can still attack the singer with ranged attacks and spells.

To represent the singer's concentration, the player must hold their arm parallel to the ground with palm facing the target.

This is a magical force and cannot be over come with strength. This song can be echoed with the Echo skill, but the character must still maintain concentration.

#### **Resist Spell Song** **Duration:** Latent

4 Spell Singing Points

This song protects the character from one spell song. It will also protect the character from the sonic attacks of screecher moss, sirens, banshees, gargoyles, and other characters that have a sonic attack. This song will last until invoked or until the end of the current Event.

A character may have only either a *Resist Spell Song* or a *Harmonize* upon them at one time, they do not stack.





### 3<sup>rd</sup> Rank Spell Songs

#### Harmonize **Duration:** Latent

##### 5 Spell Singing Points

This latent song will negate any sonic attack directed at the character. Additionally, the character adds the Spell Singing Points used to cast the song to their own. If this song is cast upon a character that does not have the Spell Singing Points skill, the sonic attack is stopped but no Spell Singing Points are gained.

Should *Harmonize* be used to stop an area effect spell song, or a sonic attack from a creature, the character does not gain any Spell Singing Points but the song effect is still negated.

A character may have only either a *Resist Spell Song* or a *Harmonize* upon them at one time, they do not stack.

#### Silence **Duration:** While Sung

##### 6 Spell Singing Points

The target character of this charm song cannot speak. This means the target cannot cast any spells, use any scrolls or use any skill that requires an in-game verbal. Any defense that would stop Charm School spells will also stop this affect. Remember: the use of latent spells, magic items, and weapon damage does not require the player to speak in-game, and is not affected by this spell. This spell can end early when a *Vocalize*, *Dispel Magic* or *Heal Limb* spell or similar effect is cast upon the target.

#### Sleep **Duration:** While Sung

##### 6 Spell Singing Points

This song is a charm affect that causes the target to fall asleep and will remain asleep for as long as the singer continues to sing. Any

defense that would stop the Charm School *Sleep* spell will also stop this affect. The target can be woken up if they receive one or more points of damage.

#### Freedom **Duration:** Instant

##### 7 Spell Singing Points

This song will free a character from the affects of any Bond School spell, Paralysis Touch, or *Paste of Binding*. This spell song will not work on mundane restraints.

### 4<sup>th</sup> Rank Spell Songs

#### Fear **Duration:** While Sung

##### 10 Spell Singing Points

This charm song causes all living characters that can hear and are in Line of Sight of the Spell Singer to run away in fear. This effect lasts as long as the singer continues to sing. If the affected characters run away and can no longer hear or no longer have Line of Sight with the Spell Singer they no longer have to run. If the character returns to the area of affect they must once again flee until they cannot see or hear the singer or the singer stops.

While feared, the character cannot take any offensive actions and can only use defensive martial skills, invoke latent defensive spells or invoke defensive magic items. While a *Heal Mind* spell or similar effect will cure the character, they may not cast the spell upon themselves until they are out of Line of Sight from the Spell Singer.

If the Echo skill is used with this song, only those originally affected are feared for 10 minutes.

#### Heroism **Duration:** While Sung

##### 14 Spell Singing Points

With this song, the Spell Singer can lift the morale of those who fight on their side. Everyone within the sound of the singer's voice and sight of the Spell Singer gains a +2 Damage Bonus and +9 Body Points that are healable.

If a character moves away from the singer but later returns they once again receive the benefit of this song, however they only gain the Body Point modifier once, if they move back into the area, they must be healed back the Body Point bonus.

This song is combinable with the affects of an *Inspire* song.

#### Remove Curse **Duration:** Instant

##### 14 Spell Singing Points

By means of this song the Spell Singer is able to remove all curses upon the target character.

#### Free Your Mind **Duration:** Instant

##### 15 Spell Singing Points

This song will remove all charm and charm like affects from the target character. This includes: Charm School spells, Vampiric Domination, Hierarch and Draconic Charms, *Forget and Remember* poison, *Amnesia* poison, Hypnosis, Satyr and Faun Charms, etc.

### 5<sup>th</sup> Rank Spell Songs

#### Repel True **Duration:** While Sung

##### 15 Spell Singing Points

This song forces all characters 10 feet away from the singer. This is a magical force and cannot be over come with strength. Once the singer completes the song, they may designate those that the song will not affect but only once at the time of completion and only for those present.



Any character affected by this song cannot attack the singer so long as they maintain this spell. Additionally, the Spell Singer cannot take any violent actions while maintaining this spell.

A defense that stops spells will negate this song if the target character invokes their defense when they are in the original area. They can move freely from that point on, entering and leaving the area of affect. However, characters that are not in the original area of affect cannot use a defense that stops spells to later enter the area.

This Spell Song cannot be combined with the Echo skill and this song cannot be dispelled.

**Haven** **Duration:** 10 Minutes

20 Spell Singing Points

This song causes all hostile actions in the sound of the singer's voice to cease. While this song is in affect, anyone entering the area is similarly affected. This area is static and does not move. This song does not compel the affected characters to remain in the area and they are able to leave when they wish.

No violent actions can enter the havened area, so even if a character leaves the area, they still cannot attack anyone within the *Haven*. Theft of any kind is considered a violent action so pick pocketing, looting a body or even picking up an item off the ground that does not belong to you is not allowed.

There is no defense to this song – even the Resist Ability, once sung the affect will remain until the duration has expired and cannot be dispelled. Even the singer is affected by this spell.

**Destroy Being** **Duration:** Instant

20 Spell Singing Points

Any character this song is sung to will be forced to the Brink of Death by the power of this melody. All characters are affected by this spell whether they take damage from Death magic or Healing magic. Characters that would normally take damage from a *Life* or *Kill* spell will take that damage instead. Inanimate objects or constructs, such as golems but not undead, are not affected by this spell. The target character can be healed as per the normal healing rules.

**Legend Life** **Duration:** Instant

24 Spell Singing Points

This song will heal a character that is at the Brink of Death and bring them to 1 Body Point. The Death System is not used when this spell is sung. This song works regardless of any other types of life affects the character has received that day with the exception of a Legend Life.

This song has the power to bring a person back from un-death, but it can only reverse the effects of the Necromancy school and only on undead created less than 1 hour. Sorcerously created undead are not affected at all by this spell.

This song cannot be cast on a person unless they are at the Brink of Death. Unlike other types of life effects, the target player can refuse the life. The Spell Singing Points are used and the character's Death Count continues.

Once a character has received a Legend Life, they cannot receive any other types of life until 7:00am.

## Warlock Advanced Career

Below is the list of skills available to players who wish to play a Warlock. For a full description of the skill, see Chapter 5.

Warlock Skill List					
Skill	Cost	Duration	Prerequisite Skill	Purchase	Tagged
Killing Blow Magic	2	Constant	Mage Basic Career SL, 4 <sup>th</sup> Rank of Any School	Once	No
Recover Power <sup>F</sup>	2	Instant	Mage Basic Career SL, 4 <sup>th</sup> Rank of Any School	Multi	Yes
Spell Binding <sup>F</sup>	4	6 Hours	Mage Basic Career SL, 4 <sup>th</sup> Rank of Any School	Multi	Yes
Spell Holding <sup>F</sup>	4	5 Min	Mage Basic Career SL, 4 <sup>th</sup> Rank of Any School	Multi	Yes
Spell Immunity	5	Constant	Mage Basic Career SL, 4 <sup>th</sup> Rank of Any School	Multi	Yes
Concentration	6	Constant	Any 3 Warlock Skills	Once	No
Double Cast <sup>F</sup>	5	Instant	Any 3 Warlock Skills	Multi	Yes
Double Power <sup>F</sup>	5	Instant	Any 3 Warlock Skills	Multi	Yes
Overlay <sup>F</sup>	6	Instant	Any 3 Warlock Skills	Multi, <i>Special</i>	Yes
Perfect Aim <sup>F</sup>	6	Instant	Any 3 Warlock Skills	Multi, <i>Special</i>	Yes
Speed Cast <sup>F</sup>	7	Instant	Any 3 Warlock Skills	Multi, <i>Special</i>	Yes
Total Power <sup>F</sup>	10	Instant	Any 3 Warlock Skills	Multi, <i>Special</i>	Yes

### Special Notes for the Warlock Skill List

- Skills with an “F” require the use of the Warlock’s focus. For all these skills, the character must simply have the focus on their person.
- Some skills – those marked as *Special* in the Purchase column – require an additional prerequisite for multiple purchases. The player should read later in this section for these prerequisites.

## The Warlock

The Warlock is the quintessential battle mage. Through a complex ceremony, a Warlock becomes attuned to the power of magic, which allows them to alter the very fabric of magic itself. A Warlock is a practitioner of high magic; trained to use low magic to its fullest potential. Warlocks use the power of magic in a chaotic manner; they are not wielders of chaos. It is in how they use their low magic, in a personal and individual way that denotes their alleged tie to chaos.

On the battlefield, a Warlock’s magic is seldom matched, and rarely defeated. Off the battlefield, the Warlock’s skills and knowledge are valuable and coveted. Some Warlocks believe all this power comes with a price...

A proficient Warlock is able to augment low magic in order to increase its effectiveness. Some of the more popular feats of a Warlock involve punching through any low magic spell defense, casting a spell without reciting a verbal, doubling the damage or duration of spells, and casting a spell at a target without throwing a spell packet.

### The Warlock Circle

The Warlocks in Avalon have formed themselves into a tight group called the Warlock Circle harking back to the old days when all Warlocks were part of a circle. However, not all Warlocks are members of this circle and some “rogue” Warlocks practice their art outside the domain of the Circle.

While the Avalonian Warlock Circle professes to be good and are supposedly dedicated to the protection of Avalon, rumors persist of a darker conspiracy tied to the Warlock’s sinister history. It is also spoken of in quiet voices of the existence of an evil Circle of Warlocks that serve their old masters still.

The Avalonian Warlock Circle conducts an initiation ceremony to their circle called the Awakening Ceremony. What goes on during this ceremony is a secret that a character must learn about in-game.



## Warlock Rules

Use of a Warlock skill does not change the Power Point cost of a spell. For the skill Double Power, the character pays the **normal** Power Point cost. For the skill Double Cast, the character pays the Power point cost of **both** spells.

Warlock skills can be combined together. The prefix associated with each skill must be included in the spell verbal, but the order in which they are used does not matter, for example: “With Total Power, Double Power, Double Cast Dragon’s Breath Spell”. The one exception to this is the Total Power and Perfect Aim skills, which can **never** be combined with the exception of special cases, such as higher beings and characters with Plot approved perks.

Sometimes Warlock skills are not lost if they do not take affect. The Spell Binding, Double Cast, Double Power, Overlay, Perfect Aim, and Total Power skills are not used if you err in their verbal, take damage or miss the target, but the Power Points are still lost. If the attack is stopped by a defense that stops spells, the skills are used and the Recover Power skill cannot be used. Recover Power, Speed Cast, and Spell Holding are used as soon as they are invoked, so if the character errs in their verbal, takes damage or misses the target, these skills are lost.

The eyes of the Warlock will glow with the color of the type of magic being used whenever the Warlock uses a Warlock skill. If a Warlock casts a latent spell, then the eyes of the target will glow when the latent spell is invoked.

**Only spells cast by the character can be augmented with their warlock skills.** Spells invoked from items or read from scrolls cannot be augmented with any Warlock skills. Skills such as Concentration which have a constant effect always work while casting, invoking, or reading a spell.

### Prerequisites and Skills

The Overlay, Perfect Aim, Speed Cast, and Total Power skills share a common prerequisite. The character needs to have 15 Power Points per each skill per each purchase. For example, a character with 75 Power Points can have any combination of skills and purchases totaling five. They could have five Overlay skills or one Overlay skill, two Speed Cast skills, and two Total Power skills. Another example, a character could have two Perfect Aim skills, two Speed Cast skills and one Total Power skill. The rest of the skills on this list do not count toward this multiple purchase limit.

### The Warlock Focus

Warlocks require a focus to use all of their abilities except the Spell Immunity, Killing Blow Magic, and Concentration skills. The Warlock focus is universal and can be used by any character. A player may have as many foci as they wish. Warlock focus, though used with magical skills, are not themselves magical and they do not detect as magical. They can be broken by any means, magical or normal. They can be identified with the Identify Component skill or by any Warlock touching one. The focus can be used a faith focus but cannot have any sorcery rituals cast upon them.

The player can acquire a focus by making one themselves, purchasing one in-game from the Merchant’s Guild, or otherwise finding one in-game.

To make one in-game, the character has to collect the required components in-game and perform a 20 minute ceremony. The character needs to know how to create the focus in-game. Once a character has learned 3 lesser Warlock skills they have the knowledge



needed to create their own focus. Below is the list of components needed to create a focus.

- Item worth at least 5 sp
- A ruby worth 1 gp
- 1 dose Red Casting Powder
- 1 dose fresh spring water
- 1 dose red swamp rose flower (whole flower)
- 9 strands of red hair
- 1 drop of blood from the Warlock creating the focus

A Warlock can still use their Warlockery without a focus; however, doing so brings them to the Brink of Death, but the spell still goes off.

### Red Casting Powder

Red Casting Powder can be used instead of the Warlock focus to use Warlock skills if the focus is not available. Red Casting Powder is measured in doses, each dose being approximately one thimble full. A single dose can be used to cast a single spell augmented by any number of Warlock skills.

*For example, Turlock lost his focus to a pick-pocket and as the thief tries to make his escape, Turlock decides to stop him, permanently. He has Red Casting Powder on him and casts his spell, “With Perfect Aim, Double Cast, Kill Spell”. The thief calls out the appropriate defenses and continues to run. Undaunted, Turlock tries again and casts another spell, “With Perfect Aim, Kill Spell”. This time the thief is done for and Turlock collects his stolen property. He has used a total of four of his Warlock skills to cast the first spell and two Warlock skills for the second, but still only used one dose of Red Casting Powder each time.*

## Master Warrior Advanced Career

Below is the list of skills available to players who wish to play a Master Warrior. For a full description of the skill, see Chapter 5.

Master Warrior Advanced Career Skill List					
Skill	Cost	Duration	Prerequisite Skill	Purchase	Tagged
Armor Efficiency	4	Constant	Warrior Basic Career SL	Once	No
Blind Fighting	5	Constant	Warrior Basic Career SL, Any Weapon Skill, 1 Master Proficiency	Once	No
Feat Of Strength	3	Instant or 15 Sec	Warrior Basic Career SL, 2 Stamina's	Multi	Yes
Master Florentine	4	Constant	Warrior Basic Career SL, Florentine, 1 Master Proficiency	Once	No
Master Parry	4	Instant	Warrior Basic Career SL, 2 Proficiencies	Multi, <i>Special</i>	Yes
Master Proficiency	13	Constant	Warrior Basic Career SL, 2 Non-Master Proficiencies	Multi	No
Shatter Weapon	5	Instant	Warrior Basic Career SL, 1 Proficiency	Multi	Yes
Shield Parry	3	Constant	Warrior Basic Career SL, 1 Proficiency, Any Shield Skill	Once	No
Slay	10	Instant	Warrior Basic Career SL, 2 Proficiencies	Multi, <i>Special</i>	Yes
Speed	6	Instant	Warrior Basic Career SL, 2 Proficiencies	Multi	Yes
True Aim	6	Instant	Warrior Basic Career SL, 1 Proficiency with a Ranged Weapon	Multi	Yes
Weapon Accuracy	3	Instant	Warrior Basic Career SL, 1 Proficiency	Multi	Yes
Weapon Barrier	6	1 Min	Weapons Master, 4 Proficiencies	Multi	Yes
Weapons Master	10	Constant	Warrior Basic Career SL, 50 Build Points of Martial Skills	Once	No
Channeling	10	Constant	2 Proficiencies, 30 Power Points, 1 <sup>st</sup> Rank School of Magic to be Channeled	Once	No
Extension	3	5 Min	Channeling	Multi	Yes
Redirect Spell	7	Instant	Channeling	Multi, <i>Special</i>	Yes

### Special Notes for the Master Warrior Advanced Career Skill List

- Some skills, such as Slay and Redirect Spell, require an additional prerequisite for multiple purchases. For example, a character needs two Proficiencies to purchase their first Slay, but they need one Proficiency for each Slay they have. The player should read the skill description in Chapter 5 for a full description of these skills, or later in this section for these prerequisites.



## The Master Warrior

The Master warrior is the toughest, strongest and most resilient person in the LAIRE world. Whether it is with a blade, hammer, spear or bow, blow for blow they are more capable than any other. Armed with both defensive and offensive skills, a battle weathered

Master Warrior can combine their experience, strength, skill and constitution to be a truly devastating force on the field of battle. They may be a righteous fighter for Duke and country or a bloodthirsty mercenary bent on greed, each and every one their own strengths and weaknesses.



## Master Warrior Rules

The Master Warrior Advanced Career is fairly straight forward. It owes no allegiance to any higher power or greater magical force. It requires no focus, no books, no components, and no special equipment – other than the warrior's weapon of course. However, there are a few things that should be pointed out to a player on how some of these Advanced Career skills work.

### Prerequisites and Skills

As a general rule, any skill with a prerequisite of a Proficiency can be satisfied if the character has a Master Proficiency. Therefore, if a



character has two Master Proficiencies and a Slay skill, the character can use their Slay skill with any weapon they have the knowledge to use. This is also true for other martial skills like Stuns, Critical Attack, or Shatter Weapon.

As was mentioned before, some skills have prerequisites that differ for multiple purchases of a skill.

Skill	Extended Prerequisite
Master Parry	1 Proficiency per Master Parry
Slay	1 Proficiency per Slay
Redirect Spell	15 Power Points per Redirect Spell

For example, a character has two Proficiency skills with Weapon Skill: One-Handed Edge and purchases two Slay skills. They can use their Slays with any One-Handed Edged weapon. The character then purchases the Weapon Skill: One-Handed Blunt skill. They cannot use their Slays with a hammer for they do not have the minimum number of Proficiencies needed to use a Slay. The character learns a Master Proficiency skill and another Slay. They can use all three Slays with their axe, but none with their hammer – they still do not meet the minimum requirements for the Slay skill. Finally, the character learns one more Master Proficiency skill. Now they may use their three Slay skills with any One-Handed Edge or One-Handed Blunt weapon they pick up.

A character must have the required number of Proficiency skills in the same weapon they wish to use the specialty skill in. For example, if a character has a Proficiency skill with One-Handed Edge and another one with One-Handed Blunt, that character does not have the required prerequisite for the Slay skill.

The prerequisite for Redirect Spell is the Channeling skill, which itself has a prerequisite of 30 Power Points. The character must have an additional 15 Power Points per Redirect Spell skill they wish to learn. So if a character wishes to learn four Redirect Spell skills, they would need to have a total of 60 Power Points, 30 Power Points for the first two skills, and fifteen more for each additional skill.

**Using Master Warrior Skills**

Some Master Warrior skills are not used if they miss their target, if the blow strikes the target character’s shield, or the target character blocks the blow with their weapon. In order for the skill to be expended for that Tag Cycle, the character must either strike their target or the target character uses an appropriate defense either magical or martial. The following skills follow this rule: Feat of Strength, Weapon Accuracy, Shatter Weapon, and Slay. Channeling works slightly differently and is discussed below.

**Channeling**

Once a character purchases the Channeling skill they are able to channel a School of Magic, specified at the time the skill is learned, through any melee weapon they are proficient in. A character may find a teacher to teach them to channel other elemental schools of magic as well at no additional cost.

In order to channel a spell, the character should recite the spell’s verbal then strike the target with their weapon. The character may cast the spell of the school they are channeling with a weapon in their hand. If the character takes damage while they are casting the spell, the spell is lost and the Power Points are expended. As with the normal rules of spell casting, the first thing the character’s weapon touches – even unintentionally such as a friend or a tree – will be affected by the spell. In other words, the character cannot choose to have the spell be released; the spell will automatically be released when it touches something. The targeted character cannot use a martial skill to parry the attack; a defense that stops spells – including the Redirect skill – must be used. Additionally, the character needs a weapon of quality to channel their spells. Normal weapons and temporarily alloyed weapons will not work. Any attempt to channel a spell using a normal weapon fails and the Power Points are expended. Should the character drop their weapon for any reason after they have already cast their spell, the spell is lost. The character must have a weapon in hand – not in their scabbard – to channel a spell or use the Redirect Spell skill.



Only the elemental schools of magic may be channeled. When the character learns to channel that school they lose access to the non-damaging spells, except for any latent spell defenses. Additionally, the character loses the ability to throw spells from that school permanently. Following is a table that outlines what spells the character can cast for each school of magic.

The character may channel any of the wall spells, but the character must use their weapon instead of their hand to trace out the wall. The same is true for the *Magic Sanctuary* spell, the character must hold up their weapon to maintain concentration.

For any spell that can only be cast on the character’s weapon, the character cannot pass the weapon on to someone else; the spell will only work with the weapon in the character’s hand.

**Only spells cast by the character can be channeled.** Spells invoked from items or read from scrolls cannot be channeled, but they can be thrown, depending on the item. If a Channeler has a sword with an Invokable Fireball spell, they can invoke the spell and strike their target just like they are channeling. However if they have an item, either Castable or Invokable, that has an embedded Fireball spell in it, they could not channel that spell through their weapon using their skill. The same is true for spells read off scrolls; a character cannot channel a Fireball spell cast from a scroll.

School	Spell	Channel Effect
Enchantments	Shock	Channelable
	Giant Strength	Latent spell can be channeled
	Shatter	Cannot be channeled
	Lightning Bolt	Channelable
	Magic Weapon	Can be cast on own weapon only
	Blast	Cannot be channeled
	Lightning Shield	Latent spell can be channeled
	Wall of Force	<i>See Above</i>
	Electrocution	Channelable
	Magic Sanctuary	<i>See Above</i>
	Circle of Force	<i>See Above</i>
	Masterful Strength	Latent spell can be channeled
	Haven	<i>See Above</i>
	Electrical Storm	Channelable
	Healing	Detect Life
Heal Person		Channelable
Purify Blood		Self Only
Assess your Ailment		Self Only
Heal Body		Self Only
Heal Mind		Self Only
Heal Limb		Self Only
Heal Mortal Wound		Cannot be channeled
Return Spirit		Cannot be channeled
Return Ghoul		Cannot be channeled
Life		Cannot be channeled
Return Death Slave		Cannot be channeled
Heal Full	Cannot be channeled	
Ice	Ice Dart	Channelable
	Frost Brand	Can be cast on own weapon only
	Ice Cast	Cannot be channeled
	Ice Shield	Latent spell can be channeled
	Ice Bolt	Channelable
	Preservation	Cannot be channeled
	Spear of Ice	Channelable
	Wall of Frost	<i>See Above</i>
	Artic Wind	Cannot be channeled
	Icy Imprisonment	Cannot be channeled
	Artic Maelstrom	Channelable
Pyrotechnics	Light	Can be cast on own weapon only
	Match	Cannot be channeled
	Flare	Channelable
	Fire Brand	Can be cast on own weapon only
	Fire Shield	Latent spell can be channeled
	Fireball	Channelable
	Inferno	Channelable
	Wall of Flame	<i>See Above</i>
	Dragon's Breath	Channelable
	Lava Burst	Channelable
	Meteor Swarm	Channelable
Volcano	Channelable	

School	Spell	Channel Effect
Death	Feign Death	Cannot be channeled
	Harm	Channelable
	Weaken	Cannot be channeled
	Maim	Channelable
	Agony	Cannot be channeled
	Take Your Sight	Cannot be channeled
	Drain Life	Channelable
	Cripple	Channelable
	Enfeeble Your Mind	Cannot be channeled
	Incapacitate	Channelable
	Spectral Weapon	Can be cast on own weapon only
	Wall of Enfeeblement	Cannot be channeled
	Kill Spell	Cannot be channeled
	Wall of Ash	Cannot be channeled

For any spell that says “Cannot be channeled” means that the character completely loses the ability to cast this spell, either through their weapon or by spell packet.

The Bonds School, which would normally be able to be channeled, currently has no spells that can be channeled.

Auras, Charms, Demonology, Necromancy, and Thaumaturgy, Schools can **never** be channeled. In addition, Nature Magic and Spell Singing can also **never** be channeled.



## Master Thief Advanced Career

Below is the list of skills available to players who wish to play a Master Thief. For a full description of the skill, see Chapter 5.

Master Thief Advanced Career Skill List					
Skill	Cost	Duration	Prerequisite Skill	Purchase	Tagged
Critical Backstab	3	Instant	Rogue Basic Career SL, 2 Backstabs	Multi	Yes
Distraction	4	10 Sec	Trap Dodge	Multi	Yes
Dodge	10	Instant	Rogue Basic Career SL, 4 Unique Dexterity Skills	Multi	Yes
Escape	4	Instant	Dodge	Multi	Yes
Master Set Traps	5	Constant	Quick Disarm, Set Trap 4	Once	No
Master Waylay	5	Constant	Waylay, 20 BP in Dexterity Skills	Once	No
Missile Deflection	3	Instant	Rogue Basic Career SL	Multi	Yes
Pick Pockets	4	Constant	Speed Search	Multi	No
Poison Immunity	5	Constant	Rogue Basic Career SL, 20 Build Points of Dexterity Skills	Multi	No
Quick Disarm Trap	5	Instant	Rogue Basic Career SL, Disarm Trap, Trap Dodge	Multi	Yes
Quick Pick Locks	5	Instant	Rogue Basic Career SL, Pick Locks, Trap Dodge	Multi	Yes
Resist Truth	3	<i>Special</i>	Rogue Basic Career SL	Multi	Yes
Set Trap 5	5	Constant	Set Trap 4	Once	No
Speed Search	6	Constant	Rogue Basic Career SL, Evaluate Item	Once	No
Trap Dodge	4	Instant	Rogue Basic Career SL, Set Trap Rank 3	Multi	Yes
Tight Rope Walker	4	Constant	Rogue Basic Career SL Climb	Once	No

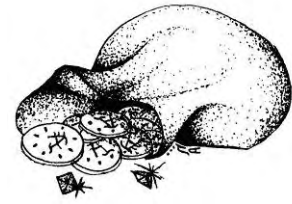

## Master Thief Rules

### Using Master Thief Skills

The Master Thief skill, Critical Backstab, is not used if the character misses their target, if the blow strikes the target character's shield, or the target character blocks the blow with their weapon. In order for the skill to be used, the character must either strike their target or if the target character uses an appropriate defense either magical or martial.

### Special Notes for the Master Thief Advanced Career Skill List

- There are no special notes for the Master Thief Advanced Career Skill List.

## The Master Thief

Master Thieves are skilled burglars, pickpockets, scouts and infiltrators. The varied skills of the Master Thief allow them to take advantage of almost any situation. No one is more adept at disarming traps and opening a lock than a Master Thief. Indeed, it is almost impossible to keep these skilled rogues out from where they are not wanted. While not good in a fight, they do possess the ability to silence a person and varied defensive skills to get themselves out of trouble.

Master Thieves have different motivations. Some steal from the rich to give to the poor while others steal from anyone and give it all to themselves. Regardless of their intentions, Master Thieves oft find themselves in trouble with the law. With abilities like Pick Pockets and Speed Search they can quickly get what they are after; with the ability to dodge, deflect arrows, distract and escape they are able to get away with the goods. Even the most secure and well guarded treasure box is emptied flawlessly in mere seconds.

In short, guard your purse, watch your treasure, and keep your valuables in a safe place for the Master Thief is out there and he has his eye on your most valued treasures.

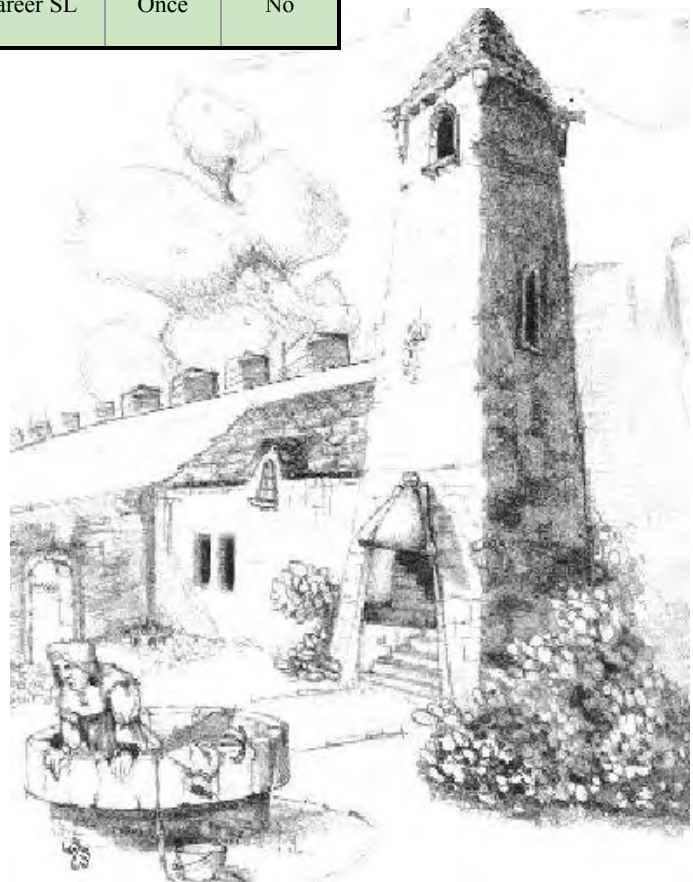



## Assassin Advanced Career

Below is the list of skills available to players who wish to play an Assassin. For a full description of the skill, see Chapter 5.

Some of the Assassin's skills are difficult to perform and others are very situational. The deadliest Assassin is one who uses all their skills wisely and is cunning enough to ensure their victory.

Assassin Advanced Career Skill List					
Skill	Cost	Duration	Prerequisite Skill	Purchase	Tagged
Master Assassin	8	Constant	Rogue Skill List, 20 Build Points of Dexterity Skills	Once	No
Assassin Proficiency	10	Constant	Master Assassin Skill	Multi	No
Assassinate	7	Instant	2 Assassin Proficiencies	Multi, <i>Special</i>	Yes
Assassin Strike	4	Instant	1 Assassin Proficiency	Multi	Yes
Blind Fighting	5	Constant	Master Assassin Skill	Once	No
Disarm	4	Instant	Master Assassin	Multi	Yes
Dodge	10	Instant	Rogue Skill List, 4 Unique Dexterity Skills	Multi	Yes
Escape	4	Instant	Dodge	Multi	Yes
Hypnosis	10	30 Min	Master Assassin Skill	Multi	Yes
Missile Deflection	3	Instant	Rogue Skill List	Multi	Yes
Paralyze Touch	5	10 Min	Master Assassin Skill	Multi	Yes
Resist Truth	3	<i>Special</i>	Rogue Skill List	Multi	Yes
True Aim	6	Instant	1 Assassin Proficiency	Multi	Yes
Weapon Accuracy	3	Instant	1 Assassin Proficiency	Multi	Yes
Poisons II-V	2/3/4/5	Constant	Rank 1 for Rank 2, Previous Rank for 3-5	Multi	No
Make Contact	3	Constant	Rank 3 Poisons	Once	No
Poison Immunity	5	Constant	Rogue Skill List, 20 Build Points of Dexterity Skills	Multi	No



### Special Notes for the Assassin Advanced Career Skill List

- The Assassinate Skill requires an additional prerequisite for multiple purchases. A character needs two Assassin Proficiency skills to purchase their first Assassinate skill, and they need one Assassin Proficiency skill for each Assassinate. The player should read the skill description in Chapter 5 for a full description of this skill, or later in this section for these prerequisites.

## The Assassin

The roles of the Assassin are numerous and can vary dramatically from person to person. An Assassin can be the good natured scout able to track down foes, or the typical killer for hire whose only allegiance is gold, or even the individual who kills for the thrill. Assassins have access to many skills, some of which are intended to deliver large amounts of damage or even kill in a single strike. They can learn to fight while blind and render a target helpless and paralyzed. Other skills allow the Assassin to strike without error from a distance or find the chink in armor. They have defensive skills as well, namely the legendary Dodge skill, which allows them to get out of most harm's way. They can learn a repertoire of skills that assist them in applying their trade such as making poisons and learning how to take control of another's will. The skills an Assassin can learn equip them to fulfill their clandestine operations.

Regardless of mindset, the Assassin is always a dangerous adversary. While stealth and cunning are their greatest weapons, Assassins can evade most situations others cannot and are skilled enough to hold their own in combat – for a short time at least. While most Master Warriors can dispatch an Assassin easily in single fair combat, it is the Assassin who will be at your back before you are aware of them striking you down before you are able to raise a cry of warning.

## Assassin Rules

Below are some special rules pertaining to the Assassin skills.

### Prerequisites and Skills

As was mentioned before, the Assassinate skill has a prerequisite that differs for multiple purchases of this skill; for every Assassinate skill the character wishes to learn, they must have one Assassin Proficiency skill.

*For example, Lascula wants to learn an Assassinate skill. He has already purchased two Assassin Proficiency skills and found a teacher. The following month, Lascula learns another Assassinate skill giving him two. Now if Lascula wishes to learn any more Assassinate skills, he will have to learn another Assassin Proficiency skill.*

### Using Assassin Skills

Some Assassin skills are not used if they miss their target, if the blow strikes the target character's shield, or the target character blocks the blow with their weapon. In order for the skill to be used the character must either strike their target or the target character uses an appropriate defense either magical or martial. The following skills follow this rule: Assassinate, Assassin Strike, Disarm, Paralyze Touch, and Weapon Accuracy.



## Follower of the Light Advanced Careers

Below is the list of skills available to players who wish to play a Cleric, Paladin, or White Sorcerer. For a full description of the skill, see Chapter 5.

Cleric and Paladin Skill List					
Skill	Cost	Duration	Prerequisite Skill	Purchase	Tagged
Cleric	3	Constant	Plot Approval, First Aid	Once	No
Heal Wounds <sup>*,V</sup>	5	Instant	Cleric	Multi	Yes
Heal Life <sup>*,V,F</sup>	10	Instant	2 Heal Wounds	Multi	Yes
Detect Undead <sup>V,F</sup>	3	Instant	Cleric	Multi	Yes
Turn Lesser Undead <sup>V,F</sup>	5	30 Min	Detect Undead	Multi	Yes
Repel Undead <sup>V,F</sup>	5	<i>Special</i>	Turn Lesser	Multi	Yes
Turn Undead Horde <sup>V,F</sup>	8	30 Min	Repel Undead	Multi	Yes
Detect Lie	3	Instant	Cleric	Multi	Yes
Holy Blessing <sup>V,F</sup>	3	10 Min	2 Heal Wounds	Multi	Yes
Paladin	2	Constant	Plot Approval, Cleric of Light	Once	No
Battle Blessing <sup>V,F</sup>	4	30 Min	Paladin	Multi	Yes
Resist Evil	5	Instant	Paladin	Multi	Yes
Destroy Lesser Undead <sup>*,V,F</sup>	3	Instant	Paladin, Detect Undead	Multi	Yes
Destroy Undead <sup>*,V,F</sup>	7	Instant	Destroy Lesser	Multi	Yes
Greater Magic Weapon <sup>V,F</sup>	5	30 Min	Paladin	Multi	Yes
Immunity to <i>Charm</i>	5	Constant	Paladin	Multi	No
White Sorcerer	3	Constant	Plot Approval, Rank 3 Sorcery	Once	No

### Special Notes for the Paladin Skill List

- Skills with an asterisk (\*) can be delivered by either touch or channeled through a weapon. No extra skill is required to deliver these skills through a weapon. A Paladin cannot channel through their weapon and their opponents, therefore if a character strikes an opponents weapon or shield, there is no effect and the skill is not used.
- Skills with a “V” require a verbal to use. If the character is unable to speak – such as being under the effect of a *Silent and Mute* spell – they are unable to use these skills. The verbal must be at least 5 syllables, not counting the skill’s name, but can be anything the player wishes, and must contain some reasonably recognizable version of the skill’s name in the verbal. For example, “By the will of the High Lord, I Turn Lesser Undead”, would be an acceptable verbal for the Turn Lesser Undead skill. Simply using the name of the skill is **not** an acceptable verbal.
- Skills with an “F” require the use of the Cleric’s or Paladin’s focus. For turning skills, the focus must be held up, but for the rest the character must simply have the focus on their person.
- All skills listed as effecting “undead” effect demons as well. For example, Destroy Lesser Undead will also work as a Destroy Lesser Demon. The player need not call anything differently.

## The Cleric, Paladin, and White Sorcerer

The High Lord is one of the three divine forces of the LAIRE game world, along with the Mother and the Dark Lord. The High Lord is eternally opposed by the Dark Lord; where the High Lord seeks to protect, the Dark Lord harms, where the High Lord seeks to nurture,

the Dark Lord corrupts and destroys. Thus their eternal fight – from the moment of their first awakening – rages across the world. This fight continues to this day, and will most likely continue to the end of time. In these modern days, the war is fought by their followers, and in the case of the High Lord, in the Cleric, Paladin and White Sorcerer.

The High Lord opposes all forms of evil and their minions, thus the High Lord and the Mother oft find themselves on the same side of the fight against necromancy and the undead.

The Cleric fills the role of guide, protector, leader, helper and sometime defender. Clerics guide

people who seek to follow the High Lord not just with teaching them,





but with their needs, charitably giving of themselves for the sake of others. Clerics primarily assist others in the fight against those who seek to harm. Clerics are more often found amongst the people helping them, then they would be involved in a fight.

Paladins are the proactive servants of the High Lord, going forth and smiting minions of the Dark Lord, undead, demons and all manner of creatures and men who seek to harm others or spread evil.

White Sorcerers are divine practitioners of sorcery, adept in the high arcane arts of sorcery as well as devoted followers of the High Lord. Their task is to help and support those who fight on the side of Light with their potent magics, for not only are they able to cast all the neutral rituals, but the potent white rituals, some of which are only available to the White Sorcerer. The White Sorcerer's role is similar to that of the Cleric, but where the Cleric teaches and guides, the White Sorcerer uses their gifts mainly to strengthen and help those who fight the good fight.

There are three primary worlds or Planes of Existence in our game. Most of the action takes place on Midlantia, the Mother's home. The Elysian Fields is the home of the High Lord and Hell is the home of the Dark Lord.

Characters wishing to follow this faith should seek out the Clerics and Paladins and find out in-game what it really means to be a Follower of the Light. As with all Advanced Skill Lists, a character should be fifth level and at least third to learn the skills associated with the High Lord's Faith. Any race that has free will can become a Follower of the Light. Characters such as goblins, orcs, trolls and other creatures that do not have free will cannot follow any faith. A character can only follow one faith at one time; therefore a character

cannot become a Servant of Darkness or a Druid while they are still a Follower of the Light.

### ***The Order of Paladins***

In Avalon, the majority of Paladins belong to the Order of Paladins. These staunch defenders of the people of Avalon are well known for their heroic deeds. All members of this order are members of the Paladin Council and one member is chosen as their leader. This order has other rules and laws they require their members to follow in addition to the laws set down by the High Lord.

Not all Paladins are members of this order and characters do not have to join the order to become a Paladin. Additionally, there may be other orders of Paladins called by different names both in the Duchy of Avalon and elsewhere on Midlantia. Players need to find them for themselves.

### ***The House of the Sun***

Within the City of Avalon and other villages, towns and keeps across the Duchy can be found holy places dedicated to the High Lord called the House of the Sun. These places, all built in the fashion of small stone keeps, have been sanctified to the High Lord and maintained by the Acolytes of the House of the Sun who dwell there. They are all open to everyone as a place of worship and refuge from the dangers of the world. Their doors are always open to the poor and needy as a place to find shelter and food. Indeed, each House of the Sun runs a soup kitchen providing food to those who cannot afford to feed themselves.

In the City of Avalon one can find the largest of these Houses of the Sun and it is frequented by many of the Followers of the Light and

heroes of Avalon who seek to commune with the High Lord or just meet their fellows when they come to the City of Avalon during their visits there.

Those who belong to the House of the Sun are called Members, many of whom live there. All members of the House of the Sun swear to be good and honorable. Some wishing to do more become Acolytes and swear to the oaths or virtues of the House of the Sun: Courage, Patience, Faith, Charity and Honor. Any player wishing to learn more about becoming a member of the House of the Sun should seek out the Acolytes in-game.

The House of the Sun can also be found in other lands across Midlantia, some seemingly developing on their own yet with similar beliefs, but the House of the Sun is not the only group to be found. Other places dedicated to the High Lord exist, and can go by other names. Regardless, all of these organizations share a common bond in following the High Lord and opposing the Dark Lord.

## Cleric, Paladin, and White Sorcerer Rules

A character can only be a follower of one faith; therefore a character may only be a Druid, a Follower of the High Lord or a Servant of the Darkness. They may only purchase skills off of one of these three lists. There are many other aspects a player should know about before embarking on this Advanced Career.

### The Laws

Clerics, Paladins and White Sorcerers must follow certain rules in order to maintain their skills and faith. These are the laws set down by the High Lord to his followers. There may be other in-game rules set down by the Council of Paladins, the House of the Sun or other in-game organizations that the character may be asked to follow, but these are the ones set down by the High Lord and the character can lose access to their skills should they break one of them.

### Clerics

- A Cleric must be good; always seeking to protect the innocent, help others, and defeat evil. They are followers of the High Lord and should endeavor to emulate his principles in their lives. A Cleric may never consciously commit an evil act, doing so immediately forfeits the character's needed purity to use their skills.
- A Cleric must assist in the destruction of evil in all its forms whenever possible and prudent. Clerics are not called upon to fight in the front lines, but rather to assist those who do by whatever skills they have. Sometimes a fight is won not by the strength of arms, but by the support of others.
- A Cleric is called to nurture, teach, advise and protect those proven to be in need. They are the spiritual leaders of the Followers of the Light.
- A Cleric must never tell a lie. A Cleric must never break an oath or promise; doing so is the same as lying. Lying, trickery, and deceit are the tools of the Dark Lord and should never be used by a Cleric.
- A Cleric may never willingly learn the Necromancy or Demonology Schools, nor may they use any necromantic or demonologist items, scrolls or abilities. They may never learn any necromantic or demonic skills or abilities. However, knowledge of evil is not evil and if the character has knowledge of Necromancy or necromantic skills they

may become a Cleric so long as they never again willingly cast these spells or use these skills. When possible they should endeavor always to remove this knowledge. They must break their contract and regain their soul before they can become a Cleric.

- A Cleric must be honorable. While a Cleric is not held to the same standards of honor as a Paladin, they still have their own code to live up to.

### Paladins

- A Paladin must be good; always seeking to defeat evil, help others, and protect the innocent. They are followers of the High Lord and should endeavor to emulate his principles in their lives. A Paladin may never consciously commit an evil act, doing so immediately forfeits the character's needed purity to use their skills.
- A Paladin must destroy evil in all its forms – undead, demons, Servants of the Dark Lord, etc. – whenever possible and prudent. The Paladins are the righteous warriors who set themselves against the charge of evil. They are the vanguard.
- A Paladin may never deny a request for aid from one proven to be defenseless and innocent.
- A Paladin must always be truthful in all they say and do. A Paladin must never break an oath or promise, doing so is the same as lying. Lying, trickery and deceit are the tools of the Dark Lord and should never be used by a Paladin.
- A Paladin may never willingly learn the Necromancy or Demonology Schools, nor may they use any necromantic or demonologist items, scrolls or abilities. They may never learn any necromantic or demonic skills or abilities. However, knowledge of evil is not evil and if the character has knowledge of Necromancy or necromantic skills they may become a Paladin so long as they never again willingly cast these spells or use these skills. When possible they should endeavor always to remove this knowledge. They must break their contract and regain their soul before they can become a Paladin.
- A Paladin must always be honorable and they are held to the highest standards of honor as an example to all whom they lead.





## White Sorcerers

- A White Sorcerer must be good; always seeking to help others, protect the innocent, and defeat evil. They are followers of the High Lord and should endeavor to emulate his principles in their lives. A White Sorcerer may never consciously commit an evil act, doing so immediately forfeits the character's needed purity to use their skills.
- A White Sorcerer must assist in the destruction of evil in all its forms whenever possible and prudent. White Sorcerers are not called upon to fight in the front lines, but rather to assist those who do by whatever skills they have. Sometimes a fight is won not by the strength of arms, but by the support of others.
- A White Sorcerer may never sell a white ritual. Receiving compensation for the components is acceptable, but they may never ask for more than the components cost. Additionally, a White Sorcerer may never deny a request for a white ritual from a good person so long as they are compensated for the components, the components are available, and they have the time and power to do so.
- A White Sorcerer must never tell a lie. A White Sorcerer must never break an oath or promise; doing so is the same as lying. Lying, trickery and deceit are the tools of the Dark Lord and should never be used by a White Sorcerer.
- A White Sorcerer may never willingly learn the Necromancy or Demonology Schools, nor may they use any necromantic or demonologist items, scrolls or abilities. They may never learn any necromantic or demonic skills or abilities. However, knowledge of evil is not evil and if the character has knowledge of Necromancy or necromantic skills they may become a White Sorcerer so long as they never again willingly cast these spells or use these skills. When possible they should endeavor always to remove this knowledge. They must break their contract and regain their soul before they can become a White Sorcerer.
- A White Sorcerer must be honorable. While a White Sorcerer is not held to the same standards of honor as a Paladin, they still have their own code to live up to.

### Codes of Honor

Honor is a very difficult concept to define, people have tried for ages and it would be difficult to fit a proper definition into this rulebook, but in the next few paragraphs an attempt will be made to give the player an idea on how to play honor as a Follower of the Light. One note, Clerics and White Sorcerers have the same level of honor and in this section, this book refers to both simply as Clerics.

When confronting a foe, the Paladin must be, as he is in all things, honest and upfront. Never should a Paladin attack a foe that is unaware of him or his intent. Nor should the Paladin strike from the shadows as an assassin in the night. On the field of battle or in personal combat, the Paladin should never stoop to the level of his opponents. Unlike the Paladin, the Cleric does not have to openly confront their foes. Clerics can attack opponents while they are at a disadvantage, either because they are unarmed or unaware of the attack. It is acceptable for Clerics to ambush their opponents. They cannot kill or attack opponents while they are sleeping or assassinate them.

When trading for goods and services the Paladin should always deal honestly and be upfront in all things. Never should he stoop to such



low acts as withholding important information or actively misleading the other person. Clerics have slightly more leeway in trading with others, they may allow the person to believe what they will or allow the person to place their own value on the item. They still may never lie and can never withhold important information or actively mislead the person they are trading with.

When dealing with others, the Paladin shall always be honest, upfront, and forthright. They may never deceive even by omission. If asked a direct question the Paladin should always answer with the complete truth, tell the person they will not answer the question, or say nothing at all. Clerics have more freedom, depending on with whom they are dealing. If they are dealing with an evil character or Servant of Darkness they are allowed to do as they will so long as they do not break their other oaths. They can withhold information or actively mislead them – anything short of actually lying to them. However with everyone else, the Cleric needs to hold themselves to a higher standard. While it is not necessary to be as forthright as the Paladin, the Cleric may go as far as allowing the person to believe what they will.

This is not a complete list by far, but should give the player a good idea of what will be expected of them as they play these Advanced Careers.

### The Cleric and Paladin Focus

Every Cleric and Paladin must have a focus to use their faith skills. All skills in the Follower of the Light Skill List Table denoted with an "F" require a focus. White Sorcerers also require a focus of sorts, their Ritual book acts as their focus.



The focus can be any item of any value, either in-game such as a piece of numbered jewelry or a weapon of quality, or in-play. When a character completes the necessary in-game requirements and learns the Cleric of Light and/or Paladin skills, they must choose a focus. The character can have only one focus at a time and should they lose their focus it must be recovered. If the focus is destroyed or lost beyond any hope of recovery, they may create a new one. The player must find out in-game how to do this.

### ***The Cardinal Oath***

Every Follower of the Light needs to make a Cardinal Oath. This oath helps to direct the character along their chosen course. The oath can be anything appropriate and is subject to Plot approval. Some examples of Cardinal Oaths taken by characters in the past are:

- To always protect the innocent.
- To help, heal and care for those in need.
- To kill all necromancers.
- To destroy all undead.
- To destroy demons.

This is not an exhaustive list, but should give the player some ideas as to what is expected.

### ***The Quest***

All Followers of the Light need to complete a quest before they can become Clerics, Paladins, or White Sorcerers. Though this quest can come to the character from various in-game sources, ultimately it is the Plot Committee who decides when a character is ready to be quested and sets down the specific quest the character must complete. Successful completion of this quest satisfies the "Plot Approval" requirement to learn the Cleric, Paladin, and White Sorcerer skills.

### ***Special Follower of the Light Skill Rules***

All characters that have Cleric or Paladin skills or is a White Sorcerer must follow their respective laws. This skill set is subject to Plot approval and can be taken away or denied access to for failing to follow these rules. Should a character lose access to their skills, they must find a way to atone for their transgression in-game.

In addition, as with other faith lists, should a Paladin or Cleric lose their free will by a spell or skill they no longer have access to their Followers of the Light Tagged Skills. This only applies to charm like effects that gives the wielder control over the target as is the case with *Enslavement*, and *Dominant* spells; Hypnosis; Demonic Charm, etc. Effects such as *Silent and Mute*, *Bedazzle*, *Speak the Truth*, etc. that do not control the character do not cause them to lose access from their faith skills. When the charm ends, the character can once again use their abilities.

The following Followers of the Light skills: Heal Wounds, Life, Destroy Lesser Undead, and Destroy Undead are not used should the player miss their target. If the target character calls a martial defense of any kind the skill is stopped but not used. If the attack takes effect or a spell defense that stops physical attacks is used, the skill is used up for that Tag Cycle. There are special rules for the Destroy Undead skill and the player should read that skill description carefully.

### ***Special White Sorcerer Rules***

Once a character learns Rank 3 Sorcery skill, they have the option of remaining a Gray Sorcerer or choosing a side. Those that choose to follow the High Lord become White Sorcerers.

The White Sorcerer gains certain benefits for aligning themselves with the light. First, they receive a +5% bonus to all white rituals. Second, they are able to cast the rituals restricted to White Sorcerers; those rituals that are designated as white only. Finally, they gain double the knowledge bonus for the ranks of the Healing School known for themselves, other casters, and participants in all rituals.

However, there are some disadvantages. They are no longer able to cast dark rituals and may never use Black Ritual Powder in their rituals. In addition, those who receive the benefit of a White Ritual become beholden to the Laws of a White Sorcerer while they are under the affects of the ritual. Should the character break any of these Laws or the White Sorcerer's Cardinal Oath, they immediately lose the benefit of the Ritual and drop to 1 Body Point max for the remainder of the Event which cannot be healed by any means. The White Sorcerer who cast the white ritual can no longer cast any white only rituals and loses their White Sorcerer Bonus for the remainder of the Event.

### ***Losing Faith***

Sometimes a Cleric, Paladin or White Sorcerer may break their laws – either accidentally or on purpose. Doing so causes the character to no longer be able to use some or all of their skills or rituals. A Plot Marshal will determine what effect breaking their laws has on the character's faith skills. In-game, the character must find a way to atone for their transgression if they wish to regain their access to their skills.

Sometimes a Cleric, Paladin or White Sorcerer commits an act they can never atone for or renounces their faith; they fall from grace. These characters lose access to their skills and cannot re-spend their Build Points, their Body Points are unaffected. A character can choose to follow a new path, choose to be a Druid or Dark Lord. If they are accepted by one of these paths, their skills are removed from their card, their Body Points gained from Follower of the Light skills are lost, and they can then use these unspent, refunded Build Points to purchase skills off the other two lists. A White Sorcerer can choose to remain a Gray Sorcerer or become a Dark Sorcerer. Either way, the character does not lose the ranks of Sorcery they already have learned.

**A character can only change faiths once ever and can never go back to their old faith.** Equally, a character can only have skills from one faith at one time ever.

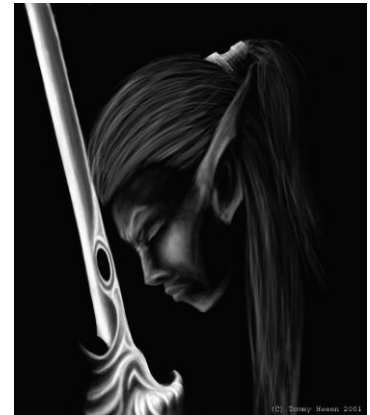

## Druid Advanced Career

Below is the list of skills available to players who wish to play a Druid. For a full description of the skill, see Chapter 5.

Druid Skill List					
Skill	Cost	Duration	Prerequisite Skill	Purchase	Tagged
Druid	5	Constant	Plot Approval and Herbal Lore	Once	No
Elemental Pool <sup>*,V,F</sup>	5	Instant	Druid	Multi	Yes
Elemental Attunement	4	Constant	2 Elemental Pool	<i>Special</i>	No
Claws <sup>V,F</sup>	3	Constant	Druid	Once	No
Pass Without a Trace	5	Constant	Druid	Once	No
Nature's Child <sup>V,F</sup>	5	10 Min	Pass Without a Trace	Multi	Yes
Forest Meld <sup>V,F</sup>	6	<i>Special</i>	Pass Without a Trace	Multi	Yes
Bark Skin <sup>V,F</sup>	4	30 Min	Pass Without a Trace	Multi	Yes
Nature's Purity <sup>F</sup>	5	10 Min	Elemental Pool	Multi	Yes
Nature's Health <sup>F</sup>	4	Constant	Elemental Pool	Once	No
Compel Mother's Children <sup>V,F</sup>	8	30 Min	Nature's Child	Multi	Yes
Hibernate <sup>V,F</sup>	3	<i>Special</i>	Forest Meld	Once	No
Shapeshift <sup>V,F</sup>	7	1 Hour	Nature's Child, Claws	Multi	Yes
Aspect of the Beast <sup>V,F</sup>	10	1 Hour	Shapeshift, Compel Mother's Children	Once	Yes
Elemental Quintessence <sup>V,F</sup>	10	1 Hour	Nature Magic Rank 3	Once	Yes
Nature Magic <sup>F</sup>	2/2/2/2		Elemental Pool, <i>Special</i>	Multi	No

### Special Notes for the Druid Skill List

- Skills with an asterisk (\*) can be delivered by either touch, thrown, or used through a weapon. No extra skill is required to deliver these skills through a weapon. A Druid cannot channel through their weapon and their opponents, therefore if a character strikes an opponents weapon or shield, there is no effect and the skill is not used.
- Skills with a "V" require a verbal to use. If the character is unable to speak – such as being under the effect of a *Silent and Mute* spell – they are unable to use these skills. The verbal must be at least 5 syllables, not counting the skills name but can be anything the player wishes, and must contain some reasonably recognizable version of the skill's name in the verbal. For example, "By the will of the Mother, I meld with the forest", would be an acceptable verbal for the Forest Meld skill. Simply using the name of the skill is **not** an acceptable verbal.
- Skills with an "F" require the use of the Druid's focus. The character must simply have the focus on their person to gain access to these skills.
- The Nature Magic skill is purchased in ranks. Each rank costs the listed Build Points. The character must have 2 purchases of the Elemental Pool skill per rank.

## The Druid

The Mother is one of the three divine forces of the LAIRE game world, along with the High Lord and the Dark Lord. While the latter eternally feud with each other, the Mother concerns herself with the aspects of the world not directly in the fight – the plants, animals and creatures She has created, in other words, nature. There are three primary worlds or Planes of Existence in our game. Most of the action takes place on Midlantia, the Mother's home. The Elysian Fields is the home of the High Lord and Hell is the home of the Dark

Lord. Druids are the followers of the Mother, Her voice and hands amongst the mortal creatures of the world ensuring above all else that life and the natural cycle of death and rebirth are maintained and the balance between the forces of Law and Chaos is kept. In times past, the battle between the forces of Good and Evil have devastated and nearly destroyed the world. The Mother's followers have been there to put things right, but they have another enemy – the undead. In a time long ago, necromancy was created, a magical force that threatens the world with destruction in a slow and nearly unstoppable way. Necromancy is an anathema to everything the Mother is and her followers are tasked with its destruction.

Characters wishing to follow this faith should seek out the Druids and find out in-game what it really means to be a Druid.



### *Druidic Society*

In the lands of Avalon and indeed most of Midlantia, the Druids have formed themselves into Circles. These Circles are lead by a High Druid and protect the local geographical regions. There is a Circle for Avalon, Barconia, Coventry, etc. This is the norm for the Druids, but there may be others who have different beliefs on how to organize themselves and this must be found out in-game.

For every Druid that is part of a circle, there is a one this not. A loner that wanders the deep forests, lonely crags, high mountain tops and low mountain valleys segregated from mortal societies. These loner types care little for other mortal races and seek to avoid them and their distractions.

Some Druids are warriors. Proactive fighter who move through nature as a predator hunting those that seek to despoil the Mother's gardens. Others are mages and scholars. They seek to teach and guide others in living in harmony with nature.

Druids seek to maintain the harmonious balance of nature and fix things when external powers upset this balance. A Druid would be called to a forest after a fire to ensure life returns naturally to the area. A land destroyed by a necromantic disease, however, has been destroyed un-naturally and a Druid would use their faith to bring life to the land once more.

Druids are neither good nor evil; there is no morality in the teachings of the Mother. The Mother teaches balance and survival through ones own skills and abilities. Overcoming adversity and difficulty proves ones own worth. It is how all things grow and become better. Some Druids take this idea of survival of the fittest to the extreme. They embrace the aggressive and sometimes violent power of nature and turn wild and feral. They see all mortal races as their enemies and lash out and try to destroy them all.

Most Druids, being moral people, have a sense of right and wrong. They may find themselves upholding some personal belief of what is right when not directly serving the interests of the Mother. This is fine, so long as their duties to the Mother and her ideals and precepts come first.

Any race that has free will can become a Druid. Characters such as goblins, orcs, trolls and other creatures that do not have free will cannot follow any faith. A character can only follow one faith at one time; therefore a character cannot become a Follower of the Light or Servant of Darkness while they are still a Druid.

### *Animal Totems and the Elements*

Once a character becomes a Druid they are given a guardian totem animal. The guardian totem is the spirit of an animal that most represents the Druid's nature and demeanor. This totem may also be called upon during Druidic ceremonies and may be called upon by the Druid while in long meditation for guidance and advice. This is also the animal form that the character will assume when they take on the Aspect of the Beast if they purchase that skill.

Druids call upon the power of the elements – those primordial forces that all things in the world are made from – while in service to the Mother. Most Druids are gifted with abilities that allow them access to these forces. When a Druid first learns the Elemental Pool skill, they choose one element to start with. This is generally the element the Druid feels closest too. They can learn to wield other elements from their pools. Those Druids, who embrace the elemental power of nature, can learn the Elemental Quintessence skill and become empowered by their favorite element.

## Druid Rules

A character can only be a follower of one faith; therefore a character may only be a Druid, a Follower of the Light, **or** a Servant of Darkness. They may only purchase skills from one of these three lists.

There are many other aspects a player should know about before embarking on this Advanced Career.

### *The Druidic Code*

There are six rules the Mother has set down for her followers to live by. There may be other in-game codes and restrictions placed upon the character by the in-game teachers and Circles but these are the ones the Mother has set. They are as follows:

- A Druid must protect and defend nature from wonton destruction and abuse at all times. The Followers of the Mother are the trusted caretakers of Her creation and are tasked with its protection. A farmer who harvests his crops or fells some trees to keep warm in the winter is using the bounty of the Mother the way she wishes. A town that destroys an entire forest to better the view of a river is abusing nature and should be stopped.
- A Druid must oppose Necromancy, its practioners, and its creations, the undead, at all times. They must destroy the undead whenever possible and prudent and either kill the necromancer or have the knowledge of necromancy removed from them. All sources of necromancy must be destroyed or purged when found. The struggle against necromancy must be fought always.
- A Druid must always tend to gardens of the Mother. The natural, wild places of the world. The forests, streams, oceans, plains, savannas, and swamps, all places where the struggle and drama of life plays out. They must always maintain the health and natural balance of nature.
- A Druid cannot ever tell a lie. In order to perform the role of guide and advisor that many Druids find themselves in, they must be trusted. Their words therefore must always be free of lies.
- A Druid may never learn Necromancy, cast any necromantic spell, or use any necromantic item. Necromancy is the Mother's bane and Her followers must not succumb to its temptations.
- A Druid may not wear metal armor – chain mail, light or heavy plate. Encasing ones self in that much metal cuts you off from the natural world around you. Let the Mother be your armor or take from the fauna and flora around you; armor of leather, bone, or wood.

### *The Druid's Focus*

Every Druid must have a focus to use their druidic skills. All skills in the Druid Skill List Table denoted with an "F" require a focus.

The focus can be any item of any value, either in-game such as a piece of numbered jewelry, a weapon of quality, or in-play. When a character completes the necessary in-game requirements and learns the Druid skill, they must choose a focus. The character can have only one focus at a time and should they lose their focus, it must be recovered. If the focus is destroyed or lost beyond any hope of



recovery, they may create a new one. The player must find out in-game how to do this.

### ***Special Druid Skill Rules***

All characters that have Druid skills must follow the Druidic Code. This skill set is subject to Plot approval and can be taken away or denied access to for failing to follow these rules. Should a character lose access to their skills, they must find a way to atone for their transgression in-game.

In addition, as with other faith lists, should a Druid lose their freewill by a spell or skill they no longer have access to their faith abilities. This only applies to charm like effects that gives the wielder control over the target as is the case with *Enslavement* and *Dominate* spells; Hypnosis; demonic charm, etc. Effects such as *Silent and Mute*, *Bedazzle*, or *Speak the Truth* that do not control the character do not cause them to lose access from their faith skills. When the charm ends, the character can once again use their abilities.

### ***Special Uses for the Elemental Pool***

When the character purchases the Elemental Pool skill, they must choose a single element to use with the pool; the character can purchase the Elemental Attunement skill to add more elements to their pool. The Druid who purchases an Elemental Pool may use it to empower their weapons with their element or throw their element as a physical attack. The list of elements, their opposites, and the damage done are listed below.

Element	Opposite	Effect
Air	Earth	Lightning Damage
Earth	Air	Earth Damage
Fire	Water	Fire Damage
Water	Fire	Ice Damage
Life	Death	Healing Damage
Death	Life	Body Damage

For all the elements, the character pays 1 Elemental Pool Point to deal one point of magic damage. When a Druid channels Death through a weapon, it will harm anything – even undead. However, due to the nature of the element, if they throw the element of Death, it will heal any character normally healed by Death Magic. If a Druid channels Life through their weapon, they will harm anything, even living characters. However, if they throw that element, they will heal living characters or harm characters that normally are harmed by healing, such as undead. Note that healing damage will do direct body damage to any character that is harmed by healing.

Druids can use their Elemental Pool through their claws in addition to their weapons.

### ***The Quest***

All Druids need to complete a quest before they can become Druids. Though this quest can come to the character from various in-game sources, ultimately it is the Plot Committee who decides when a character is ready to be quested and sets down the specific quest the character must complete. Successful completion of this quest satisfies the “Plot Approval” requirement to learn the Druid skill.

### ***Losing Faith***

Sometimes a Druid may break their code – either accidentally or on purpose. Doing so causes the character to no longer be able to use some or all of their skills and spells. A Plot Marshal will determine

what effect breaking the Druidic Code has on the character’s faith skills. In-game, the character must find a way to atone for their transgression if they wish to regain their access to their skills.

Sometimes a Druid commits an act they can never atone for or renounces their faith; they fall from grace. These characters lose access to their skills and cannot re-spend their Build Points, but their Body Points are unaffected. A character can choose to follow a new path, either to be a follower of the High Lord or Dark Lord. If they are accepted by one of these paths, their skills are removed from their card, the Body Points gained from Druidic Skills are lost, and they can then use these unspent, refunded Build Points to purchase skills off the other two lists.

**A character can only change faiths once ever and can never go back to their old faith.** Equally, a character can only have skills from one faith at one time ever.





## Nature Magic

Nature Magic works just like any regular low magic school; it must be learned rank by rank, requires the use of the correct full verbal and costs Power Points. Standard spell defenses will stop the effects of these spells – *Negation*, *Spell Shield*, etc – except the character gains no Elemental Pool Points or Power Points if an *Absorption* spell is used. A character can use the *Redirect* skill to redirect a Nature Magic spell.

Nature Magic spells cannot be used with Warlock skills, Create Scroll skill, or Sorcery Rituals.

In order to learn ranks of Nature Magic, the character must meet the following requirements in addition to the listed prerequisites.

Rank	Elemental Pool Purchases
1	2
2	4
3	6
4	8

Below is the list of spells available in each rank of Nature Magic.

### 1<sup>st</sup> Rank Nature Magic

Spell Verbal: By Nature's Will, I...

**...Create Food and Water** **Duration:** Instant  
2 Power Points

With this spell, the Druid may produce an edible meal out of the earth. The meal created is the minimum requirement for healthy survival for one person for a day. The food is neither very filling nor great in quality. The Druid also causes a small jet of water to spring from the ground for one minute producing 4 liters of pure drinking water.

The Druid may produce food for themselves for the month instead of paying the monthly maintenance to Logistics.

**...Repel this Being** **Duration:** While Concentrating  
3 Power Points

This spell compels the target character to be unable to attack the Druid with attacks or spells. If the Druid attacks the target, the spell will end.

The spell lasts as long as the Druid concentrates. Out-of-game, in order to represent this, the player must hold their arm outstretched parallel to the ground with their palm facing towards the target.

This spell is a charm like effect and therefore can be stopped by *Resist Suggestion* spell, the *Iron Will* skill, *Elven Resist* skill, and other defenses that stop charms in addition to other defenses that stop spells.

### 2<sup>nd</sup> Rank Nature Magic

Spell Verbal: By Nature's will, I...

**...Entangle Your Limbs** **Duration:** 3 Seconds  
4 Power Points

This spell causes vines to rise up and entangle the targeted character's arms and legs together and pinning them to the ground for 3 seconds. While under the effects of this spell, the character is unable to move and must place their arms at their sides and legs together.

If the target has a +10 or greater Strength Bonus, Non-Combinable they are unaffected at all by this spell. The character must have this before they are affected by the spell, they cannot invoke latent spells or skills or invoke items to gain the +10 Strength Bonus, Non-Combinable after they are affected by this spell to free themselves.

**...Heal Your Disease** **Duration:** Instant  
4 Power Points

This spell will cure most diseases, including the one caused by the *Cause Disease* and *Plague* spells.

### 3<sup>rd</sup> Rank Nature Magic

Spell Verbal: By Nature's will, I...

**...Strike You Down with Thunder and Lightning** **Duration:** Instant  
9 Power Points

Target character suffers 24 points of damage from magical lightning and effected by a 5 second Torso Stun.

Note that shields of quality will stop all the effects of this spell.

**...Grow a Wall of Brambles** **Duration:** End of Current Tag Cycle or Until Destroyed  
9 Power Points

This spell creates a 10 foot by 10 foot by 1 foot nearly impassable wall of thorny vines and brambles. The wall is non-magical and can be destroyed by receiving 100 Body Points of damage or a *Kill Spell*. The wall suffers double damage from fire attacks.

Any creature attempting to pass through the wall suffers 14 points of normal damage and becomes stuck in the wall. Any creature stuck in the wall may push their way through in 5 seconds with a +3 or greater Strength Bonus. Characters with a +6 or greater Strength Bonus may pass unhindered but not undamaged.

The *Wall of Brambles* follows the normal wall spell rules except that the Druid need not concentrate to maintain the wall. The Druid must have a 10 foot long piece of green garland to represent the wall. When the wall is first cast, anyone in the area of effect must choose which side of the wall they wish to wind up on.

The wall remains until the end of the current Tag Cycle or the wall has taken enough damage to destroy it. The wall may not be removed by a *Dispel Magic* or *Sever Magic* spell and the wall cannot be healed, but the caster can freely pass through the wall at will. If the player who cast the wall leaves Line of Sight, they should sign and leave the Elemental Pool Points with the garland. Any damage done to the wall that does not destroy it should be recorded on the tag.

Other than what was stated above, this follows the normal wall spell rules.

### 4<sup>th</sup> Rank Nature Magic

Spell Verbal: By Nature's will, I...

**...Travel Through this Tree to Another Place** **Duration:** Special  
12 Power Points

By use of this spell, the Druid may transport themselves and all items carried and worn through one tree to another. The tree must be touched and be at least one foot in diameter. The Druid may take one other willing, living character with them.

After completion of the verbal, the character must put on a white headband. From the time the Druid puts on a white headband, they have 20 seconds to reach the other tree and the Druid cannot be

blocked by other characters while moving. If the Druid does not reach another tree by that time, they are brought to the Brink of Death and rise up through the earth where the time ran out with everything they are carrying including another character. This additional character is not harmed.

The Druid cannot drop or pick up any items while they are tree walking.

Note that the player does not call a Hold to use this spell.

**...Transmute Your Flesh to Stone Forever**      **Duration:** End of Current Event

14 Power Points

The targeted character and all items carried or in hand including Mithril and magical items are turned to magical stone until the end of the current Event.

The target is not dead but in stasis, their Death Count and all other timed effects – alchemical durations, diseases, Death Slave, etc. – stop. They cannot be affected by physical attacks or spells including those augmented by Warlockery.

The affected character may be moved with a +6 Strength Bonus, Non-Combinable or better.

This spell may be undone with *Oil of Stone to Flesh* or *Restore Flesh* spell or certain sorcery rituals. *Dispel Magic* and *Sever Magic* spells have no effect on the stoned character. The Druid who cast the spell can remove it by touching the player.

**...Restore You Back to Flesh Again**      **Duration:** Instant

14 Power Points

This spell turns a character that is currently turned to stone back to being flesh again in the same state they were when turned to stone. Therefore, if a character was Mortally Wounded and then turned to stone, they are still Mortally Wounded and their Death Count continues.

This will undo most turn to stone effects such as a Basilisk's gaze, a Gorgon's Gaze, the *Flesh to Stone* spell or similar spells or effects.

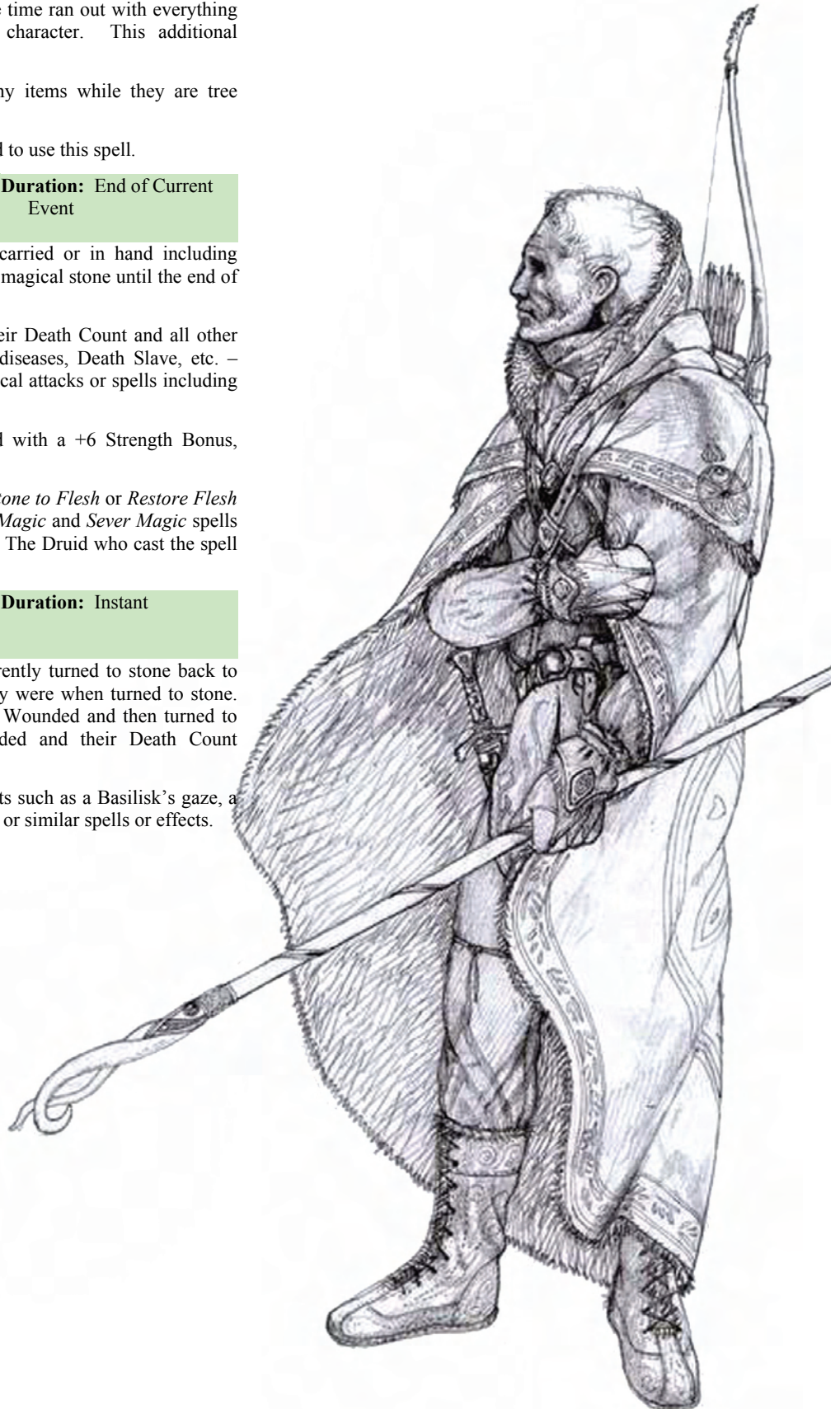

## Servant of Darkness Advanced Careers

Those players looking to play a Servant of Darkness should keep in mind a few things. First, **Avalon is a good and lawful society**. This means that the in-game Duchy of Avalon does not condone its citizens to follow the Dark Lord, and therefore worship of the Dark Lord in any way is against the law. While this does not mean a player cannot play a Dark Cleric, Dark Paladin, or Dark Sorcerer, it does mean that **in-game actions have in-game consequences**. If you make the choice to play one of these character types you must be prepared that you may not be able to play your character openly in town and should you get caught, your character may be killed or banished making you a fugitive. A player therefore should think very carefully before becoming a Servant of Darkness.

Below is the list of skills available to players who wish to play a Dark Paladin. For a full description of the skill, see Chapter 5.

Dark Cleric and Dark Paladin Skill List					
Skill	Cost	Duration	Prerequisite Skill	Purchase	Tagged
Dark Cleric	3	Constant	Plot Approval	Once	No
Cloak Undead <sup>V,F</sup>	5	6 Hours	Dark Cleric	Multi	Yes
Control Lesser Undead <sup>V,F</sup>	6	30 Min	Dark Cleric	Multi	Yes
Compel Greater Undead <sup>V,F</sup>	6	30 Min	Control Lesser Undead	Multi	Yes
Control Undead Horde <sup>V,F</sup>	10	30 Min	Compel Greater Undead	Multi	Yes
Dark Blessing <sup>V,F</sup>	3	10 Min	2 Wounding	Multi	Yes
Lie	3	Instant	Dark Cleric	Multi	Yes
Wounding <sup>*,V</sup>	5	Instant	Dark Cleric	Multi	Yes
Dark Paladin	2	Constant	Plot Approval, Dark Cleric	Once	No
Death Touch <sup>*,V,F</sup>	10	Instant	Venom Touch	Multi	Yes
Empower Evil <sup>V,F</sup>	5	Latent	Dark Paladin, Dark Blessing	Multi	Yes
Greater Magic Weapon <sup>V,F</sup>	5	30 Min	Dark Paladin	Multi	Yes
Immunity to Charm	5	Constant	Dark Paladin	Multi	No
Pain Touch <sup>*,V,F</sup>	6	5 Min	Dark Paladin, 2 Wounding	Multi	Yes
Sever Soul <sup>*,V,F</sup>	4	Instant	Death Touch	Multi	Yes
Unlife	8	<i>Special</i>	Dark Paladin, Cloak Undead	Once	No
Venom Touch <sup>*,V,F</sup>	8	5 Min	Pain Touch	Multi	Yes
Dark Sorcerer	3	Constant	Plot Approval, Rank 3 Sorcery	Once	No

### Special Notes for the Dark Paladin Skill List

- Skills with an asterisk (\*) can be delivered by either touch or channeled through a weapon. No extra skill is required to deliver these skills through a weapon. A Dark Paladin cannot channel through two weapons, therefore if a character strikes an opponents weapon or shield, there is no effect and the skill is not used.
- Skills with a "V" require a verbal to use. If the character is unable to speak – such as being under the effect of a *Silent and Mute* spell – they are unable to use these skills. The verbal must be at least 5 syllables, not counting the skill's name but can be anything the player wishes, and must contain some reasonably recognizable version of the skill's name in the verbal. For example, "By the might of Bazmodeous, I stricken you with pain", would be an acceptable verbal for the Pain Touch skill. Simply using the name of the skill is **not** an acceptable verbal.

- Skills with an "F" require the use of the Dark Paladin's focus. For controlling and compelling skills, the focus must be held up, but for the rest, the character must simply have the focus on their person.
- All skills listed as affecting "undead" effect demons as well. For example, Control Undead Horde will also work as a Control Demonic Horde. The player need not call anything differently.

## The Dark Cleric, Dark Paladin, and Dark Sorcerer

All that is dark and evil comes from the Dark Lord; the wellspring of malevolence, necromancy, evil and all things vile in the universe. The Dark Lord is one of the three divine forces of the LAIRE game world, along with the Mother and the High Lord.

The Dark Lord seeks to spread death, destruction, evil, suffering and misery throughout the world. The Dark Lord's rival is the High Lord and their eternal struggle has raged throughout time and continues to this day carried on by his servants the Dark Cleric, the Dark Paladin, and the Dark Sorcerer, from all of whom the Dark Lord brooks no disobedience and demands complete servitude.

The Dark Lord has many minions at his command: the mortal creatures his servants the Hierarchs created, – the goblins, orcs, trolls, ogres and many, many more – demons and other minions of Hell, and the undead. It is because of the undead that the Followers of the Mother oft find themselves at odds with the Servants of Darkness. It

however does not end there. The Dark Lord's minions and servants frequently destroy life where they find it, and the Servants of the Mother are there to protect nature.

The Dark Cleric fills the role of insurgent, spreading lies and corruption amongst the people where they live. They lead their followers, teaching them the ways of the Dark Lord. They find any and all ways to spread the evil of the Dark Lord and foster their own dark desires.

Dark Paladins are the shining beacon of darkness,





the open antagonists of the Dark Lord. They are the champions of evil; ever seeking the downfall of those who follow the ideals of the High Lord, destroy, oppress, and rule the common man, and ever seeking to spread their master's evil.

Dark Sorcerers are divine practitioners of sorcery, adept in the high arcane arts of sorcery as well as servants of the Dark Lord. Their task is to help and support those who fight on the side of evil with their potent magics, for not only are they able to cast all the neutral rituals, but the potent dark rituals some of which are only available to the Dark Sorcerer. The Dark Sorcerer's role is mainly to strengthen and help those who fight on the side of evil.

There are three primary worlds or Planes of Existence in our game. Most of the action takes place on Midlantia, the Mother's home. The Elysian Fields is the home of the High Lord and Hell is the home of the Dark Lord.

Perhaps the first test a player faces is finding a teacher. Characters wishing to follow this faith should seek out the Dark Clerics and Dark Paladins and find out in-game what it really means to be a Servant of Darkness. As with all Advanced Skill Lists, a character should be fifth level and at least third to learn the skills associated with the Dark Lord's Faith. Any race that has free will can become a Servant of Darkness. Characters such as goblins, orcs, trolls and other creatures that do not have free will cannot follow any faith. A character can only follow one faith at one time; therefore a character cannot become a Follower of the Light or a Druid while they are still a Servant of Darkness.



## Dark Cleric, Dark Paladin, and Dark Sorcerer Rules

A character can only be a follower of one faith; therefore a character may only be a Druid, a Follower of the High Lord or a Servant of the Dark Lord. They may only purchase skills off of one of these three lists.

There are many other aspects a player should know about before embarking on this Advanced Career.

### The Laws

Dark Clerics, Dark Paladins and Dark Sorcerers must follow certain rules in order to maintain their skills and faith. These are the laws set down by the Dark Lord to his servants. There may be other in-game rules set down by the other in-game organizations that the character may be asked to follow, but these are the ones set down by the Dark Lord and the character can lose access to their skills should they break one of them.

#### Dark Clerics

- A Dark Cleric must be evil. Forever shall they be bound to the will of the Dark Lord and ever foster his ideals and precepts.
- A Dark Cleric must destroy good whenever possible and prudent. Dark Clerics are not called upon to fight on the front lines of the war against the light, but they are required to seek its destruction by whatever means is available to them.
- A Dark Cleric may never willingly commit a truly selfless act, they may however feign goodness in order to fool others and ingratiate themselves with those they seek to corrupt and destroy.
- A Dark Cleric must always obey the Dark Lord and those who bear his word. Sometimes there may be those who will lie and claim they were given sovereignty over the Dark Cleric. It is up to the Dark Cleric to determine the validity of this claim, but should they choose wrongly, they will be punished accordingly.

#### Dark Paladins

- A Dark Paladin must be evil. Forever shall they be bound to the will of the Dark Lord and ever foster his ideals and precepts. A Dark Paladin must be overtly evil, a shining beacon of darkness and evil. Dark Paladins are the ultimate champions of evil and must act accordingly.
- A Dark Paladin must destroy good whenever possible and prudent. Dark Paladins are called upon to fight on the front lines of the war against the light, and they are required to seek its destruction.
- A Dark Paladin may **never** willingly commit a selfless act, **even** to feign goodness in order to fool others and ingratiate themselves.
- A Dark Paladin must always obey the Dark Lord and those who bear his word. Sometimes there may be those who will lie and claim they were given sovereignty over the Dark Paladin. It is up to the Dark Paladin to determine the validity of this claim, but should they choose wrongly, they will be punished accordingly.

**Dark Sorcerers**

- A Dark Sorcerer must be evil. Forever shall they be bound to the will of the Dark Lord and ever foster his ideals and precepts.
- A Dark Sorcerer must always exact a price, be it coin or some other self serving fee, in exchange for any dark ritual they cast on another.
- A Dark Sorcerer may never willingly commit a truly selfless act, they may however feign goodness in order to fool others and ingratiate themselves with those they seek to corrupt and destroy.
- A Dark Sorcerer must always obey the Dark Lord and those who bear his word. Sometimes there may be those who will lie and claim they were given sovereignty over the Dark Sorcerer. It is up to the Dark Sorcerer to determine the validity of this claim, but should they choose wrongly, they will be punished accordingly.

***What is Evil?***

The quick and easy answer to this: selfishness. This is a broad answer. Evil is the man who kills his brother's fiancé on the day of their wedding for she did not return his love. Evil is the man who kills his mother and father to inherit their title. Evil is the woman who sacrifices a village to the Dark Lord to summon a demon to this world to be used in her conquest of others. Evil is a woman who seduces a man only to kill him on their honeymoon for his magic sword. Evil is finding and practicing new and more depraved ways of torturing a person to not only enjoying witnessing their suffering but to be able to boast of the skills to others.

These examples are what is expected of a Servant of Darkness. The Dark Lord does not award his gifts to practitioners of petty evil. Stealing a few coppers from the bar in the inn and trying to claim the gifts of the Dark Lord will earn you nothing less than scorn, ridicule and a one way trip to the Healer's Guild.

***Honor and the Servants of Darkness***

Some could argue that honor is the purview of those that follow the High Lord, but it is possible to be a Servant of Darkness and be honorable.

***The Dark Cleric and Dark Paladin Focus***

Every Dark Cleric and Dark Paladin must have a focus to use their faith skills. All skills in the Dark Cleric and Dark Paladin Skill List Table denoted with an "F" require a focus. Dark Sorcerers also require a focus of sorts, their ritual book acts as their focus.

The focus can be any item of any value, either in-game such as a piece of numbered jewelry or a weapon of quality, or in-play. When a character completes the necessary in-game requirements and learns the Cleric of Darkness and/or Dark Paladin skills, they must choose a focus. The character can have only one focus at a time and should they lose their focus it must be recovered. If the focus is destroyed or lost beyond any hope of recovery, they may create a new one. The player must find out in-game how to do this.

***The Cardinal Oath***

Every Servant of Darkness needs to make a Cardinal Oath. This oath helps to direct the character along their chosen course. The oath can

be anything appropriate and is subject to Plot approval. Some examples of Cardinal Oaths taken by characters in the past are:

- To kill the innocent.
- To destroy all Paladins.
- To spread the taint of necromancy.
- To destroy all Solars.

This is not an exhaustive list, but should give the player some ideas as to what is expected.

***The Quest***

All Servants of the Dark Lord need to complete a quest before they can become Dark Clerics, Dark Paladins, or Dark Sorcerers. Though this quest can come to the character from various in-game sources, ultimately it is the Plot Committee who decides when a character is ready to be quested and sets down the specific quest the character must complete. Successful completion of this quest satisfies the "Plot Approval" requirement to learn the Dark Cleric, Dark Paladin, and Dark Sorcerer skills.

***Special Servants of Darkness Skill Rules***

All characters that have Dark Cleric or Dark Paladin skills or is a Dark Sorcerer must follow their respective laws. This skill set is subject to plot approval and can be taken away or denied access to for failing to follow these rules. Should a character lose access to their skills, they must find a way to atone for their transgression in-game.



In addition, as with other faith lists, should a Dark Paladin or Dark Cleric lose their free will by a spell or skill, they no longer have access to their Servant of Darkness tagged skills. This only applies to charm-like effects that gives the wielder control over the target as is the case with *Enslavement*, and *Dominate* spells; Hypnosis; Demonic Charm, etc. Effects such as *Silent and Mute*, *Bedazzle*, *Speak the Truth*, etc. that do not control the character do not cause them to lose access from their faith skills. When the charm ends the character can once again use their abilities.

The following Servant of Darkness skills: Pain Touch, Wounding, Death Touch, and Venom Touch are not used should the player miss their target. If the target character calls a martial defense of any kind the skill is stopped but not used. If the attack takes effect or a spell defense that stops physical attacks is used, the skill is used up for that Tag Cycle.

### ***Special Dark Sorcerer Rules***

Once a character learns Rank 3 Sorcery skill, they have the option of remaining a Gray Sorcerer or choosing a side. Those that choose to follow the Dark Lord become Dark Sorcerers.

The Dark Sorcerer gains certain benefits for aligning themselves with evil. First, they receive a +5% bonus to all dark rituals. Second, they are able to cast the rituals restricted to Dark Sorcerers; those rituals that are dark only. Finally, they gain double the knowledge bonus for the ranks of the Necromancy School known for themselves, other casters, and participants in all rituals.

However, there are some disadvantages. They are no longer able to cast white rituals and must use Black Ritual Powder in their dark rituals. In addition, those who receive the benefit of a dark ritual become beholden to the Laws of a Dark Sorcerer and the Dark Sorcerer's Cardinal Oath while they are under the affects of the ritual. Should the person break any of these Laws, they immediately lose the benefit of the ritual, are immediately brought to the Brink of Death, and drop to 1 Body Point max for the remainder of the Event and cannot be healed by any means. The Dark Sorcerer who cast the dark ritual can no longer cast any dark only rituals, no longer receives their +5% bonus, and drops to 1 Body Point max for the remainder of the Event and cannot be healed by any means.

### ***Losing Faith***

Sometimes a Dark Cleric, Dark Paladin or Dark Sorcerer may break their laws – either accidentally or on purpose. Doing so causes the character to no longer be able to use some or all of their skills and spells. A Plot Marshal will determine what effect breaking their laws has on the character's faith skills. In-game, the character must find a way

to atone for their transgression if they wish to regain their access to their skills.

Sometimes a Dark Cleric, Dark Paladin or Dark Sorcerer commits an act they can never atone for or renounces their faith; they fall from grace. These characters lose access to their skills and cannot spend their Build Points, but their Body Points are unaffected. A character can choose to follow a new path, choose to be a Druid or High Lord. If they are accepted by one of these paths, their skills are removed from their card, their Body Points gained from Servant of Darkness skills are lost, and they can then use these unspent, refunded Build Points to purchase skills off the other two lists. A Dark Sorcerer can choose to remain a Gray Sorcerer or become a White Sorcerer. Either way, the character does not lose the ranks of Sorcery they already have learned.

**A character can only change faiths once ever and can never go back to their old faith.** Equally, a character can only have skills from one faith at one time ever.





## Master Miscellaneous Skills

Below is the list of skills available to all players. **The character must be Level 5 to learn any of these skills.** For a full description of the skill, see Chapter 5.

Master Miscellaneous Skill List					
Skill	Cost	Duration	Prerequisite Skill	Purchase	Tagged
Autopsy	2	Instant	Battle Surgery	Once	No
Climb	3	<i>Special</i>	None	Once	No
Coma	7	Constant	None	Once	No
Courage	3	5 Min	None	Multi	Yes
Darkwood Ranger	3	Constant	Tracking	Once	No
Interrogate	3	Instant	None	Multi	Yes
Iron Will	10	Instant	None	Multi	Yes
Jump	3	<i>Special</i>	None	Once	No
Swim	3	<i>Special</i>	None	Once	No
Tracking	6	Constant	None	Once	No

### *Special Notes for the Master Miscellaneous Skill List*

- There are no special rules for the Master Miscellaneous Skill List.

## Master Miscellaneous Skills

The skills on the Master Miscellaneous Skills list are available to all characters regardless of their Advanced Career. They are the equivalent of the master level of the basic miscellaneous skills.

### *Learning Master Miscellaneous Skills*

Any character can learn a Master Miscellaneous skill, but they all require the teacher to have a teach skill. Any Advanced Career teach skill will do and the character needs to have the skill.

*For example, Garric has the Teach Alchemy skill and also has the Courage and Coma skills. He is able to teach any character, not just Alchemists, the Courage and Coma skills.*





# Chapter 5: Skill Descriptions...

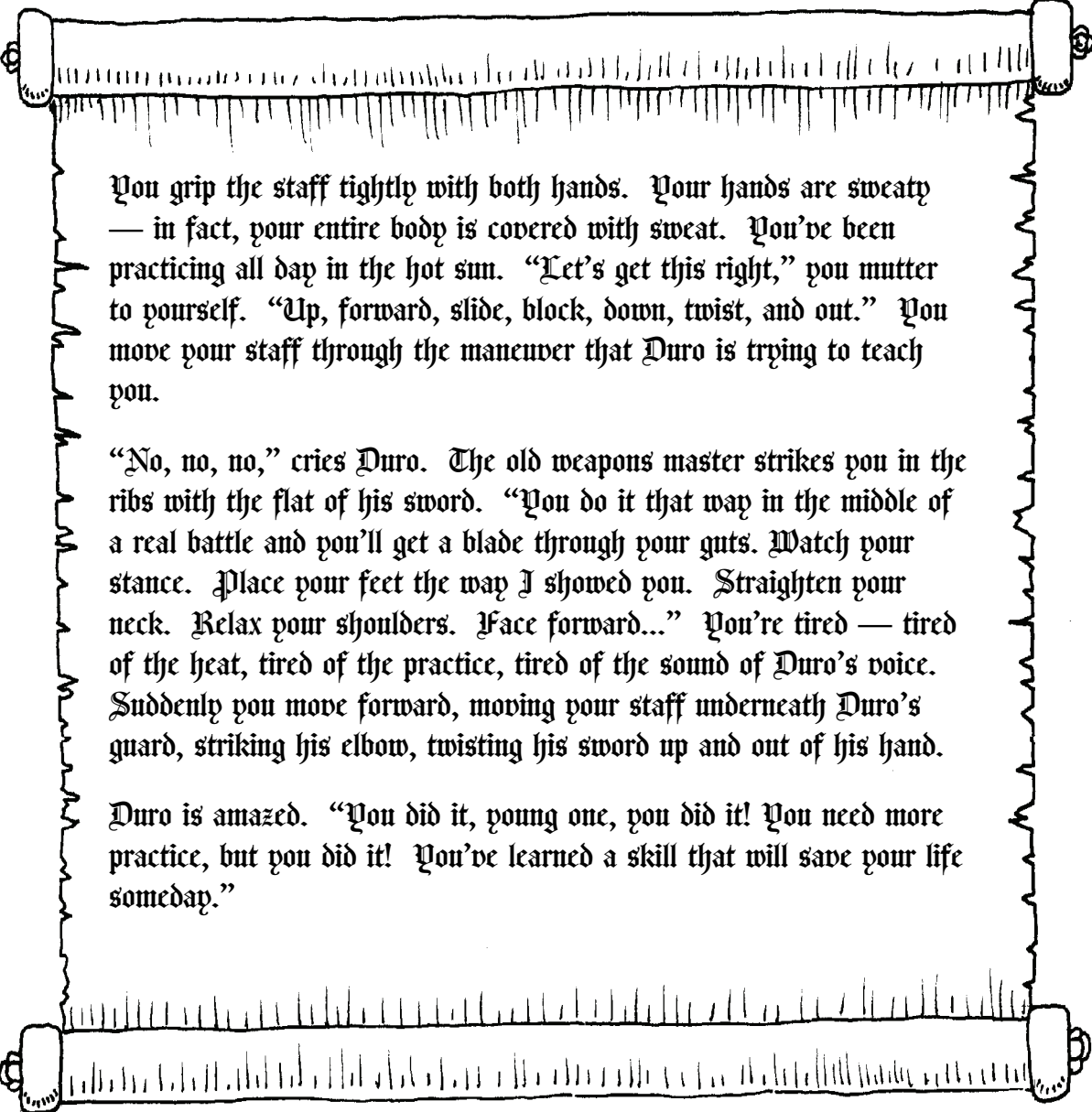

You grip the staff tightly with both hands. Your hands are sweaty — in fact, your entire body is covered with sweat. You've been practicing all day in the hot sun. "Let's get this right," you mutter to yourself. "Up, forward, slide, block, down, twist, and out." You move your staff through the maneuver that Duro is trying to teach you.

"No, no, no," cries Duro. The old weapons master strikes you in the ribs with the flat of his sword. "You do it that way in the middle of a real battle and you'll get a blade through your guts. Watch your stance. Place your feet the way I showed you. Straighten your neck. Relax your shoulders. Face forward..." You're tired — tired of the heat, tired of the practice, tired of the sound of Duro's voice. Suddenly you move forward, moving your staff underneath Duro's guard, striking his elbow, twisting his sword up and out of his hand.

Duro is amazed. "You did it, young one, you did it! You need more practice, but you did it! You've learned a skill that will save your life someday."

This chapter outlines all the skills in our game in alphabetical order and lists a description and the rules for each skill. For more information on how these skills relate to the various Basic and Advanced Careers, please see the appropriate section elsewhere in this book.

### How to Use this Chapter

A heading that summarizes some of the important information pertaining to that skill precedes each description listed in this chapter. Below is a summary of the various items found in the headings in this chapter.

#### Build Cost

This is the cost in Build Points the character must spend to learn the skill. Some skills have an on-list and off-list cost. These costs are denoted by two numbers separated by a slash with the following convention: *<On-List Cost>/<Off-List Cost>*.

#### Purchase

This heading indicates how many times a character can purchase this skill. "Once" indicates that the skill is a continuous or constant skill and is usable whenever the player wants. "Multi" indicates that the skill can be purchased as many times as the character wants. Rarely, some skills are only purchasable a limited number of times; this is indicated with a number followed by "Times", for example "3 Times".

#### Tagged

Some skills are usable a limited number of times per Tag Cycle per purchase and require a tag from logistics. The Slay skill, for example, can only be used once per Tag Cycle per purchase. These skills are denoted with "Yes". Skills that can be used as often as the character wishes or make a permanent change to the character and need no tag are marked with a "No". For example, a Literacy skill allows the character to read that language whenever they wish, or the Coma skill permanently changes the character's Death Count.

#### Duration

Certain skills have a duration once activated or "Called", others have an instantaneous effect. Skills are either denoted by "Instant", a time – 5 Minutes, 1 Hour – or "Constant" for those skills than can be used whenever the character is able. Some skills are listed as "Latent" can be used on a character to be invoked later. Some of these skills can be called as a defense to an attack or invoked for a duration giving the character some bonus effect. The player should read the description carefully to determine how exactly these skills work.

#### Skill Type

Each skill is classified by the type of skill it is. These classifications determine the Body Points gained for each skill. For example, Nature's Child is classified as a Faith skill and the character gains 1.0 Body Points (5 BP x 0.2) for that skill.

#### Prerequisite

Many skills, especially Advanced Career Skills, have prerequisites to purchasing them. These prerequisites must be met before the character can purchase the skill. **Remember, in the case of Advanced Career Skills the character must be Level 5 to purchase those skills off the Advanced Career Skill Lists.**

**Additionally, any prerequisite that is encompassed in another skill counts towards the prerequisite.** For example, Master Florentine requires the Warrior Basic Career Skill List and

Florentine; but if the character learns Weapons Master they do not need the Florentine skill to learn Master Florentine, Weapons Master effectively gives them the Florentine skill.

#### Skill List

This heading denotes on what Skill List or lists the skill can be found. If there is no Skill List associated with a skill, then a character needs a specific teach skill in order to teach that skill. These skills are denoted by "None" under this heading.



## Skill Descriptions

### A

#### Advanced Refining

<b>Build Cost:</b>	5	<b>Purchase:</b>	Once
<b>Tagged:</b>	No	<b>Duration:</b>	Constant
<b>Skill Type:</b>	Arcane		
<b>Prerequisites:</b>	Identify Component		
<b>Skill List:</b>	Alchemist		

With this skill a character is able to get two doses out of one component. The time it takes depends on the rarity of the component. Below is a table that outlines how long it takes to double a component.

Rarity	Time (Minutes)
Common	1
Un-Common	5
Rare	10
Very Rare	15

When a character uses this skill the marshal should note that the component was doubled by placing a “D” on the tag. Reagents cannot be doubled, only Major Components.

Once doubled, a component cannot be used in sorcery rituals, even if both halves of the component are used. A component that has been doubled cannot be doubled again.

#### Advanced Strength

<b>Build Cost:</b>	10	<b>Purchase:</b>	Once
<b>Tagged:</b>	No	<b>Duration:</b>	Constant
<b>Skill Type:</b>	Martial		
<b>Prerequisites:</b>	Superior Strength		
<b>Skill List:</b>	Miscellaneous Skill List		

This skill turns the non-combinable Strength Bonus of the Superior Strength skill to a combinable Strength Bonus.

#### Alchemy Lore

<b>Build Cost:</b>	2	<b>Purchase:</b>	Once
<b>Tagged:</b>	No	<b>Duration:</b>	Constant
<b>Skill Type:</b>	Arcane		
<b>Prerequisites:</b>	Literacy, Herbal Lore		
<b>Skill List:</b>	Alchemist		

This skill allows the character to recognize alchemical reagents. This is the basic Alchemy skill and grants the character the ability to brew, distill, mix, and perform the other basic skills needed to create alchemical items. It does not grant the character the ability to actually make anything; a separate skill is required for that. Alchemy Lore is required to read and identify alchemical recipes in-game.

#### Alchemical Focus

<b>Build Cost:</b>	0	<b>Purchase:</b>	Once
<b>Tagged:</b>	No	<b>Duration:</b>	Constant
<b>Skill Type:</b>	Arcane		
<b>Prerequisites:</b>	Alchemy Lore, Rank 3 of Any School		
<b>Skill List:</b>	Alchemist		

This Alchemist only skill allows the character to make use of Alchemist only alchemical items that are categorized as Alchemical Focus.

#### Armor Efficiency

<b>Build Cost:</b>	4	<b>Purchase:</b>	Once
<b>Tagged:</b>	No	<b>Duration:</b>	Constant
<b>Skill Type:</b>	Martial		
<b>Prerequisites:</b>	Warrior Basic Career Skill List		
<b>Skill List:</b>	Master Warrior		

Normally, after every battle, a character wearing armor will lose 3 Armor Points after spending 5 minutes resetting their armor. With the purchase of this skill, the character gains two advantages. The first grants the character one-quarter their starting Armor Points (rounded up) added to their starting Armor Points. This includes the Real Armor Bonus.

The second ensures that the character will always have one-quarter their starting Armor Points after resetting their armor. The character must still spend the 5 minutes in-game resetting their armor after a battle to gain this benefit.

Torso armor must be worn to use this skill. The character may remove the other parts of their armor: their helmet, greaves, gauntlets, etc. but still has to wear their torso armor.

*For example, Sir Derrick has a chain mail shirt, studded leather vambraces, and light plate greives totaling 15 Armor Points. With this skill he gains a bonus of +4 Armor Points totaling 19 Armor Points. After a battle he adjusts his armor and is now at 16 Armor Points. Over the course of the event his armor is lowered to 5 Armor Points. Once more Sir Derrick gets into a battle, but at the end of this battle when he resets his armor he will have 4 Armor Points, the minimum he can have with this skill.*

This skill does not augment magical Armor Points such as those from an *Armor* spell, an alchemical item, magic items, or rituals.

#### Armor Smith

<b>Build Cost:</b>	3	<b>Purchase:</b>	Multi
<b>Tagged:</b>	Yes	<b>Duration:</b>	Special
<b>Skill Type:</b>	Miscellaneous		
<b>Prerequisites:</b>	None		
<b>Skill List:</b>	Miscellaneous Skill List		

Each purchase of this skill allows the character to repair 6 Armor Points of cloth, leather, or metal armor. It takes the character 5 minutes to repair up to 6 Armor Points; so if a character has three purchases of this skill, it will take them 5 minutes to repair 1 to 6 Armor Points, 10 minutes to repair 7 to 12 Armor Points, and 15 minutes to repair 13 to 18 Armor Points. The character may break up their repair points any way they wish up to their maximum number of repair points.

This skill is not used if the character is inside an armory when repairing armor.

This skill will also allow the character to make a new piece of armor. For every purchase of this skill, the character can make a piece of leather or metal armor worth up to 6 Armor Points; so a character with three purchases of this skill can make a piece of leather or metal armor worth up to 18 Armor Points.

Four purchases of the Armor Smith skill is needed for Elven Crafting, Dwarven Crafting, Bone Crafting, and Enchantment Quality. Five purchases of the Armor Crafting skill is needed for Mithril Crafting.

For full details on creating armor see the description under the Miscellaneous Skill List in Chapter 2.

**Aspect of the Beast**

<b>Build Cost:</b>	10	<b>Purchase:</b>	Once
<b>Tagged:</b>	Yes	<b>Duration:</b>	1 Hour
<b>Skill Type:</b>	Faith		
<b>Prerequisites:</b>	Shapeshift, Compel Mother's Children		
<b>Skill List:</b>	Druid		

When this skill is purchased, the character embraces the animalistic power of nature and gains the ability to call upon their guardian animal totem and merge with it, transforming their body into a bipedal version of the character's guardian totem animal. All armor and items worn are unchanged in the new form.

When a character transforms, they must drop to their hands and knees or crouch for 1 minute to roleplay the shift. During this time, the character puts on the appropriate costuming for the animal which must be at least a mask and a tabard approved by Plot. The character can be attacked and harmed during this time and no skills or abilities can be used. The Druid may call latent spell defenses or invoke spell defenses from items, however. Taking damage will not interrupt the transformation unless the Druid is rendered unconscious or worse. If the character is interrupted, they do not use the skill for that Tag Cycle.

When transformed, the Druid gains the following abilities:

- +20 Body Points
- +1 Strength Bonus
- +1 Damage Bonus with their claws only
- One special ability based on the type of totem (see table below)
- Immunity to all charm effects
- Immunity to Fear
- May still use their Druid skills, even Nature Magic

They also suffer the following detriments while shapeshifted:

- They cannot speak common and therefore cannot use any skills, spells, powers, or items that require a verbal, but can understand what others are saying, and can be understood by Druids.

Category <i>Examples</i>	Special Ability
Insects <i>Ants, Beetles</i>	20 Natural Armor, Acid Spit, 18 points of damage x2
Bears	+10 Body Points, +1 Strength Bonus, Non-combinable
Canines <i>Wolves, Hyenas</i>	+1 Damage Bonus, Master Parry, Track by Scent
Felines <i>Lions, Tigers</i>	+1 Damage Bonus, Critical Attack, Track by Scent
Primates, Equines	+1 Damage Bonus, Feat of Strength Skill x2
Reptiles <i>Snakes, Lizards, Testudines</i>	10 Natural Armor, Threshold of 2 (stackable), Poison Spit: Blindness
Scorpions	20 Natural Armor, Poison Spit: 24 Point Damage x2
Spiders	10 Natural Armor, Webbing x3

**The character must receive approval from the Plot Director for their totem animal and the final category benefits.** If a character has a totem that is not represented in the above table, the closest match will be assigned.

While in their aspect, the character appears as a half animal half man version. The character gains no special movement powers or the ability to walk on four (or more) legs.

While in animal form, the character may use their Druid skills and Nature Magic spells. They still need to say the appropriate verbal but, in-game, the characters around them do not understand what they are saying. Also, they may use any latent spell normally.

When the character changes back to their natural form and they are down Body Points, the bonus Body Points the character gains from changing are the first to be lost. Therefore, if the character normally has 20 Body Points and uses this skill they would have 45 Body Points. If the character was down 18 Body Points when they changed back, they would be at 20 Body Points – the normal for their natural form. Willingly changing back to their natural form takes the character however long it takes to remove their costume.

The change normally lasts 1 hour, but the character may change back to their natural form at will. If while in the animal form, the character is brought to the Brink of Death, they are forced back into their natural form.

This skill requires the use of the character's focus and a verbal, which must be at least 5 syllables, not including the skill's name, and must contain some reasonably recognizable version of the name of the skill.

**The character may only purchase Aspect of the Beast or Elemental Quintessence, not both. Once learned this skill cannot be unlearned in order to purchase the other skill.**

**Assassinate**

<b>Build Cost:</b>	7	<b>Purchase:</b>	Multi, <i>Special</i>
<b>Tagged:</b>	Yes	<b>Duration:</b>	Instant
<b>Skill Type:</b>	Dexterity		
<b>Prerequisites:</b>	2 Assassin Proficiency Skills		
<b>Skill List:</b>	Assassin		

This skill allows a character to strike down a target character with one strike. The target character needs to be surprised or incapacitated

such as being Torso Stunned, paralyzed, asleep, etc. The character hit with this skill is Mortally Wounded and requires the appropriate healing. This skill ignores armor and does not damage it. The character must strike the arm between the elbows and the shoulders, or the body between the shoulders and the knees of the target character. The character must call “Assassinate” after the blow is delivered followed by any special damage modifiers, such as “Magic”, “Silver”, etc. Unlike other skills, this skill only requires the character to call the effect loud enough for the target to hear. However, anyone who hears the word “assassinate” is aware of the attack.

Only non-blunt weapons gained with the Master Assassin skill can be used to assassinate a target character.

The character using this skill needs to surprise their target. As a general rule, if the target character is surprised by the attack, the assassinate works. The most common way to achieve surprise is by attacking from behind, but a character need not do that. They can walk up to their target, shake their hand and assassinate them with their other. This skill cannot be used if the character is fighting their target. The character may assassinate someone if they are fighting another opponent, however. Even if the target turns their back and runs, you can assassinate them, however the attack still has to be a surprise.

A character must have one Assassin Proficiency skill per Assassinate skill they wish to purchase, after the first purchase. So, a character that wants three Assassinate skills must have three Assassin Proficiency skills.

This skill is not used if the character misses their target or the attack is blocked. If they succeed in striking their target or if the target calls an appropriate defense the skill is used.

### Assassin Proficiency

<b>Build Cost:</b>	10	<b>Purchase:</b>	Multi
<b>Tagged:</b>	No	<b>Duration:</b>	Constant
<b>Skill Type:</b>	Dexterity		
<b>Prerequisites:</b>	Master Assassin Skill		
<b>Skill List:</b>	Assassin		

For each purchase of this skill a character gains a Damage Bonus with all Master Assassin weapons according to the table below.

Weapon Type	Damage Bonus
Small, Thrown, One-Handed, and Crossbows	+1
Bows	+1.5 <sup>†</sup>

This skill may be combined with other Damage Bonuses. The Assassin Proficiency skill is not hand specific.

<sup>†</sup> Note: The bonus is rounded down so one purchase give a +1 Damage Bonus and two purchases give a +3 Damage Bonus.

### Assassin Strike

<b>Build Cost:</b>	4	<b>Purchase:</b>	Multi
<b>Tagged:</b>	Yes	<b>Duration:</b>	Instant
<b>Skill Type:</b>	Dexterity		
<b>Prerequisites:</b>	1 Assassin Proficiency		
<b>Skill List:</b>	Assassin		

This skill allows the character to double their weapon damage for one swing. The player should double the amount of damage their character is swinging including base weapon damage, Damage Bonus, Strength Bonus, alchemical effects, or magic bonuses. This attack does not need to be from surprise or behind. Any defense that stops physical attacks will stop this skill.

The character is able use multiple purchases of this skill to increase the amount of damage in one attack, increasing the multiplier by one for each additional tag used. There is no limit to the number of Assassin Strike skills the character can use in one attack.

*For example, Silk has five purchases of the Assassin Strike skill. He decides to use one use of this skill against a foe. He normally swings 10 points of damage with his sword, and calls “20 Strike” when he hits with this skill. Later on that Tag Cycle, Silk again decides to use his Assassin Strike skill, but this time he needs to be sure to take down his foe. He decides to use his remaining four Assassin Strike tags for five times his base damage. He makes his attack and strikes his opponent calling “50 Strike,” felling his opponent easily.*

The character using this skill should suffix his normal damage with “...Strike”.

This skill is not used if the character misses their target or the attack is blocked. If they succeed in striking their target or if the target calls an appropriate defense the skill is used. This skill does not double any additional damage from the Heal Wounds skill, Wounding skill, or Elemental Pool Points.

### Autopsy

<b>Build Cost:</b>	2	<b>Purchase:</b>	Once
<b>Tagged:</b>	No	<b>Duration:</b>	Instant
<b>Skill Type:</b>	Arcane		
<b>Prerequisites:</b>	Battle Surgery		
<b>Skill List:</b>	Master Miscellaneous		

This skill allows a character to determine the cause of death of a character in their Death Count or a corpse. This skill will tell if the cause of death is from a Slay, Assassinate, poison, general damage, magical effect, the spell and its school, etc. It can tell what type of weapon was used, but not what specific weapon it was.

A character can only Autopsy one character at a time. The use of this skill requires the character to concentrate while they are using this skill. The player should look at the character they are using this skill on and can only talk and invoke Latent spells while autopsying someone. If the use of this skill is interrupted by either taking damage or the character choosing to stop, the attempt fails. If the character wishes to try to autopsy again they must start from the beginning.

This skill does not stop a character’s Death Count, nor can their Death Count be stopped by any means and still use this skill. For example, a character cannot use Battle Surgery skill to stop the Death Count.

This skill takes 1 minute to use.



## B

**Backstab**

<b>Build Cost:</b>	6/12	<b>Purchase:</b>	Multi
<b>Tagged:</b>	No	<b>Duration:</b>	Constant
<b>Skill Type:</b>	Dexterity		
<b>Prerequisites:</b>	Waylay		
<b>Skill List:</b>	Rogue Basic Career Skill List		

When this skill is purchased the character gains a +1 Damage Bonus to all their attacks from behind with any weapon. This skill is hand specific and the character must choose whether to apply the Damage Bonus to either their right or left hand when they purchase this skill. The character must be approximately 90 degrees behind their target to be considered behind them. The character cannot reach their arms around the target to gain their Damage Bonus.

This skill is stackable with itself and all Backstabs learned are cumulative. So a Backstab +4 would allow the character to cause 6 points of damage with their long sword.

**Bark Skin**

<b>Build Cost:</b>	4	<b>Purchase:</b>	Multi
<b>Tagged:</b>	Yes	<b>Duration:</b>	30 Minutes
<b>Skill Type:</b>	Faith		
<b>Prerequisites:</b>	Pass Without a Trace		
<b>Skill List:</b>	Druid		

This skill calls upon the strength and toughness of the trees to make the character stronger, adding 12 Body Points to the character that can be healed. These extra points are the first Body Points lost when the character is damaged.

To use this skill, the character must touch a living, healthy, normal, non-sentient tree with bark.

This skill requires the use of the character's focus and a verbal, which must be at least 5 syllables, not including the skill's name, and must contain some reasonably recognizable version of the name of the skill.

**Battle Blessing**

<b>Build Cost:</b>	4	<b>Purchase:</b>	Multi
<b>Tagged:</b>	Yes	<b>Duration:</b>	30 Minutes
<b>Skill Type:</b>	Faith		
<b>Prerequisites:</b>	Paladin		
<b>Skill List:</b>	Follower of the Light		

This skill will make the character immune to the special attacks of undead and demon kind. The character will take full damage, but un-augmented by special effects. The Paladin cannot be paralyzed, diseased, life-drained, feared, or affected by any other ability from these creatures.

*For example, Nilrick uses his Battle Blessing skill before he goes into battle against some undead. He will still take the damage the ghouls are causing but will not be paralyzed. Additionally, the wraiths he is fighting will not swing for direct Body Points with their attacks. During the fight Nilrick falls and a Wight attempts to drain some of his life force but the Battle Blessing skill will prevent the attempt from succeeding.*

This is not a defense to any Servant of Darkness skills or spells from these characters.

This skill requires the use of the character's focus and a verbal, which must be at least 5 syllables, not including the skill's name, and must contain some reasonably recognizable version of the name of the skill.

**Battle Surgery**

<b>Build Cost:</b>	4	<b>Purchase:</b>	Multi
<b>Tagged:</b>	Yes	<b>Duration:</b>	Special
<b>Skill Type:</b>	Miscellaneous		
<b>Prerequisites:</b>	First Aid		
<b>Skill List:</b>	Miscellaneous Skill List		

For every purchase of this skill, the character can spend 1 minute to restore Body Points to a character. The character may use this skill any time they wish on any living character, including themselves. For every purchase of this skill the character can restore 10 Body Points. No matter how many Body Points restored, the character need only take 1 minute to use this skill. The character can restore any amount of Body Points they wish with this skill up to their maximum amount. **To use this skill in this manner requires the character to have bandages to wrap the character in.** One area of the body per use of this skill (or per 10 Body Points restored) is required. The player using this skill is responsible for providing the bandages. The target character must keep the bandages on for at least 10 minutes. If the bandages are removed or fall off before the 10 minutes are up, the Body Points healed with this skill are lost and the use of this skill is still expended.

A character can only be battle surgeried by one character at a time and a character can only battle surgery one character at a time. The use of this skill requires the character to concentrate while they are using this skill. The player should look at the character they are using this skill on and can only talk and invoke Latent spells while battle surgering someone.

One complete use of this skill can be used to indefinitely stabilize a living character who is Mortally Wounded or at the Brink of Death. The character should place their hand on the character's torso and call "Battle Surgery". As long as the character maintains contact, the target character's Death Count stops.

The bandage is in-game, does not have to be purchased, must be white, and must be larger than 2 feet by 3 inches. The character must either have their hand on the target character or be bandaging to use this skill.

**Blind Fighting**

<b>Build Cost:</b>	5	<b>Purchase:</b>	Once
<b>Tagged:</b>	No	<b>Duration:</b>	Constant
<b>Skill Type:</b>	Martial		
<b>Prerequisites:</b>	1 Master Proficiency ~ or ~ 1 Assassin Proficiency		
<b>Skill List:</b>	Master Warrior, Assassin		

This skill enables a blinded character to engage in hand to hand combat; without this skill a character may not engage in combat while blinded. This skill does not imply the ability to see. A character using this skill is assumed to be fighting by "feel" and sound, and can only respond to a hand to hand attack and cannot initiate combat with a foe that they cannot perceive. Once combat starts, the character can continue until the target leaves the combat entirely or out runs the player.

This skill cannot be used – **ever** – to detect invisible characters, but can be used to attack invisible characters that attack first.

## C

## Claws

<b>Build Cost:</b>	3	<b>Purchase:</b>	Once
<b>Tagged:</b>	No	<b>Duration:</b>	Constant
<b>Skill Type:</b>	Faith		
<b>Prerequisites:</b>	Druid		
<b>Skill List:</b>	Druid		

This ability allows the character to turn one or both hands into claws and allows them to use an approved LAIRE claw in combat dealing 1 point of magical damage with each blow. The claws are part of the character's body and may not be coated with poison as doing so would poison the character. Even if the character were immune to the poison, the poison would be expended when applied. The character's claws take damage and any damage dealt to the claws is taken from the character's Body Points.

Damage Bonuses and special weapon attacks, like the Slay, Stun, Waylay, Assassinate, etc. skills, with the exception of the Speed skill and *Inspire* and *Heroism* spell songs, may not be used with the Claws skill. However, the character's Strength Bonus does add to the damage.

Claws always swing for magic damage. The character has the option of using their Elemental Pool Points to increase the amount and type of damage dealt.

This skill requires the use of the character's focus and a verbal, which must be at least 5 syllables, not including the skill's name, and must contain some reasonably recognizable version of the name of the skill.

## Channeling

<b>Build Cost:</b>	10	<b>Purchase:</b>	Once
<b>Tagged:</b>	No	<b>Duration:</b>	Constant
<b>Skill Type:</b>	Martial		
<b>Prerequisites:</b>	2 Proficiency Skills, 30 Power Points, 1 <sup>st</sup> Rank School of Magic to be Channeled		
<b>Skill List:</b>	Master Warrior		

This skill allows a character to channel a school of magic through their weapon. For the character's strike, the weapon acts as a spell packet so one only needs to contact the target, their weapon, or shield for the spell to take effect. The full spell verbal for the spell must be recited and the casting can be interrupted normally, however the character can cast the spell with their weapon in hand for that school only. The channeled spell costs the normal amount of Power Points.

Upon learning this skill the character loses the ability to throw the spells from that school of magic, they are limited to channeling them only. The character can only cast damaging spells from that school and they lose the ability to cast non-damaging spells. The character may cast some latent spells in that school by touch with their weapon upon anyone.

Channeling a spell replaces the normal damage the weapon would do, even if the typical weapon damage is more than the spell's damage. Channeling strikes cannot be combined with any specialty martial attacks including the Speed skill. Channeling strikes also cannot be combined with any Warlock skills except the Concentration and Speed Cast skills.

The character can channel through any weapon of quality, even a magic weapon. Normal weapons and temporarily alloyed weapons

will not work. Any attempt to channel a spell using a normal weapon fails and the Power Points are expended. In the special case of weapons enchanted with an element, only that element can be channeled.

If a character misses their target, they can continue to try and strike their target until they connect with a blow or 5 seconds elapses. If the character accidentally strikes the ground or some other inanimate object, the spell is lost. If a Dodge skill is used to defend the target from the attack, the spell is lost. Martial defenses, such as the Critical Strike or Master Parry skills, cannot be used to stop the effects of the channeled spell; however, it can be used to take the effects of the spell for another character.

The character can learn to channel other elemental schools of magic, but these must be learned separately and cost no additional Build Points.

Only Low Magic Schools can be learned to be channeled, therefore, Spell Songs and Nature Magic cannot be channeled. This skill can only be used with a spell cast by the character and not when invoked from an item or read from a scroll.

## Cleric

<b>Build Cost:</b>	3	<b>Purchase:</b>	Once
<b>Tagged:</b>	No	<b>Duration:</b>	Constant
<b>Skill Type:</b>	Faith		
<b>Prerequisites:</b>	Plot Approval, First Aid		
<b>Skill List:</b>	Follower of the Light		

This skill grants the character a limited immunity to necromancy. The character is immune to any undead creation spell in the Necromancy School. Damaging spells from that school still effect the character normally and a *Death Slave* spell brings the character to the Brink of Death. Undead creating sorcery rituals effect the character, but they are at half power, in other words, half the normal Body Points, Power Points, Strength Bonus, Skills, etc. and is wracked with constant pain and agony. After the end of the current Event in which the undead was created, the player can choose to end their character's undead torment whenever they want, even if the character is on their last death.

## Climb

<b>Build Cost:</b>	3	<b>Purchase:</b>	Once
<b>Tagged:</b>	No	<b>Duration:</b>	<i>Special</i>
<b>Skill Type:</b>	Dexterity		
<b>Prerequisites:</b>	None		
<b>Skill List:</b>	Master Miscellaneous		

This skill has only one use, to overcome obstacles encountered during game play which do not physically exist. It cannot be used to climb over a stone wall if the stone wall is there out-of-game, but if the Marshal only describes the wall or if the wall is only represented by a tarp, string or other such out-of-game item, then the character can use this skill. The Marshal will have final say as to whether the character successfully uses this skill. It typically takes the character 10 seconds to climb 20 feet, although the character can climb any height with this skill.

This skill can never be used to enter or exit combat, nor can it be used to attack from trees, roofs or other out of reach locations. A character absolutely cannot stand next to a tree and say they have climbed the tree and attack other characters. Ever.

**Cloak Undead**

<b>Build Cost:</b>	5	<b>Purchase:</b>	Multi
<b>Tagged:</b>	Yes	<b>Duration:</b>	6 Hours
<b>Skill Type:</b>	Faith		
<b>Prerequisites:</b>	Dark Cleric		
<b>Skill List:</b>	Servant of Darkness		

For 6 hours, this skill will cloak any corporeal undead making them appear to be alive. The *Detect Life* spell, First Aid skill, or Detect Undead skill will reveal the character as being alive. The character will look as they did in life and will appear to have flesh, be warm to the touch and otherwise appear to be a living breathing character. The undead will even appear to bleed if struck. However, if the undead is immune to a class of weapons or spells, then no effect will show. This skill will also protect the character from sunlight for the duration of this skill.

This skill provides no protection from damage and will not work on incorporeal undead such as Wraiths or Specters.

This skill requires the use of the character's focus and a verbal, which must be at least 5 syllables, not including the skill's name, and must contain some reasonably recognizable version of the name of the skill. verbal, which must be at least 5 syllables, not including the skill's name, and must contain some reasonably recognizable version of the name of the skill.

**Coma**

<b>Build Cost:</b>	7	<b>Purchase:</b>	Once
<b>Tagged:</b>	No	<b>Duration:</b>	Constant
<b>Skill Type:</b>	Martial		
<b>Prerequisites:</b>	None		
<b>Skill List:</b>	Master Miscellaneous		

When a character purchases this skill they permanently change their Death Count, effectively doubling the amount of time the character has at each stage. Therefore, it takes them 2 minutes to Bleed to Death, are Mortally Wounded for 2 minutes, and will be at the Brink of Death for 10 minutes. This skill does not affect how long they are Unconscious, when they are at 0 Body Points, or Waylaid; it is still 5 minutes.

If another character uses the First Aid skill or a *Detect Life* spell, in addition to receiving their Death Count status, they will know the character has the Coma skill.

**Compel Greater Undead**

<b>Build Cost:</b>	6	<b>Purchase:</b>	Multi
<b>Tagged:</b>	Yes	<b>Duration:</b>	30 Minutes
<b>Skill Type:</b>	Faith		
<b>Prerequisites:</b>	Control Lesser Undead		
<b>Skill List:</b>	Servant of Darkness		

This skill allows the character to bend any single undead or demon of any type within hearing range and line of sight to their will for 30 minutes. The targeted character will do exactly what the user commands; care should be taken that these commands are explicit since the target character may carry out the letter but not the spirit of the command. After the duration of this ability expires, the undead may seek revenge for being controlled, depending on its personality and the nature of the commands given. If given a command within the designated time period, the undead must attempt to accomplish and complete the command to the best of its ability, within the duration of this skill. If the duration should expire, all incomplete commands are forfeit, and the target character is free to react of its

own free will. This skill can be used as a counter to the Follower of the Light turn skills. This skill can only be countered by a Follower of the Light skill, Servant of Darkness skill, or sorcery; necromancy or abilities will not counter this ability. A character cannot use this skill on themselves.

This skill requires the use of the character's focus and a verbal, which must be at least 5 syllables, not including the skill's name, and must contain some reasonably recognizable version of the name of the skill.

**Compel Mother's Children**

<b>Build Cost:</b>	8	<b>Purchase:</b>	Multi
<b>Tagged:</b>	Yes	<b>Duration:</b>	30 Minutes
<b>Skill Type:</b>	Faith		
<b>Prerequisites:</b>	Nature's Child		
<b>Skill List:</b>	Druid		

This skill uses the Druid's influence and tie to nature to compel all natural animals within hearing range or Line of Sight of the character to obey their commands for 30 minutes. When the skill's duration ends, all incomplete commands are forfeit, and the animals will return to their own will and react according to their nature. This skill can be countered by sorcery or any other spell or ability that charms the animal.

This skill is not a charm effect and only works on characters with the Animal type on their card (see LAIRE's Codex of Monstrous Creatures).

This skill requires the use of the character's focus and a verbal, which must be at least 5 syllables, not including the skill's name, and must contain some reasonably recognizable version of the name of the skill.

**Concentration**

<b>Build Cost:</b>	6	<b>Purchase:</b>	Once
<b>Tagged:</b>	No	<b>Duration:</b>	Constant
<b>Skill Type:</b>	Arcane		
<b>Prerequisites:</b>	Any 3 Warlock Skills		
<b>Skill List:</b>	Warlock		

This skill allows a character to cast spells while they are taking damage. Once purchased, this skill is always in affect. This skill does not protect a character from taking damage; it only allows them to ignore the damage for the purpose of casting spells. Concentration does not prevent a character from being paralyzed, knocked unconscious, affected by a *Bind* spell, or otherwise rendered physically unable to cast spells.

**Control Lesser Undead**

<b>Build Cost:</b>	6	<b>Purchase:</b>	Multi
<b>Tagged:</b>	Yes	<b>Duration:</b>	30 Minutes
<b>Skill Type:</b>	Faith		
<b>Prerequisites:</b>	Dark Cleric		
<b>Skill List:</b>	Servant of Darkness		

Any lesser undead and lesser demons within hearing range or Line of sight of the character must obey all the character's commands for 30 minutes. If the duration should expire, all incomplete commands are forfeit, and the undead will return to their own will and react according to their nature. This skill can be used as a counter to the Follower of the Light turn skills. This skill can only be countered by a Follower of the Light skill, Servant of Darkness skill, or sorcery; necromancy or abilities will not counter this skill. A character cannot use this skill on themselves.



This skill requires the use of the character's focus and a verbal, which must be at least 5 syllables, not including the skill's name, and must contain some reasonably recognizable version of the name of the skill.

### Control Undead Horde

**Build Cost:** 10                      **Purchase:** Multi  
**Tagged:** Yes                      **Duration:** 30 Minutes  
**Skill Type:** Faith  
**Prerequisites:** Compel Greater Undead  
**Skill List:** Servant of Darkness

All undead and all demons within hearing range or Line of Sight of the character must obey their commands for 30 minutes. Greater Undead will act as if affected by the Compel Undead skill. If the duration should expire, all incomplete commands are forfeit, and the undead will return to their own will and react according to their nature. This skill can be used as a counter to the Follower of the Light turn skills. This skill can only be countered by a Follower of the Light skill, Servant of Darkness, or sorcery; necromancy or abilities will not counter this ability. A character cannot use this skill on themselves.

This skill requires the use of the character's focus and a verbal, which must be at least 5 syllables, not including the skill's name, and must contain some reasonably recognizable version of the name of the skill.

### Cosmic Focus

**Build Cost:** 0                      **Purchase:** Once  
**Tagged:** No                      **Duration:** Constant  
**Skill Type:** Arcane  
**Prerequisites:** Rank 1 Sorcery  
**Skill List:** Sorcerer

This Sorcerer only skill allows the character to access rituals that are categorized as Cosmic Focus rituals.

### Courage

**Build Cost:** 3                      **Purchase:** Multi  
**Tagged:** Yes                      **Duration:** 5 Minutes  
**Skill Type:** Miscellaneous  
**Prerequisites:** None  
**Skill List:** Master Miscellaneous

When a character learns this skill, they may resist the effects of any and all fear abilities, spells or effects for 5 minutes. This skill will also resist the use of the Interrogate skill.

The player should call "Courage" when they invoke this skill and when affected by any additional fear effects during the skill's duration.

### Craftsman Skills

**Build Cost:** 3                      **Purchase:** Multi  
**Tagged:** No                      **Duration:** Constant  
**Skill Type:** Miscellaneous  
**Prerequisites:** None  
**Skill List:** Miscellaneous Skill List

This set of skills allows a character to create in-game commodities not covered elsewhere in these rules. The character needs to pay 100% of the production cost only, not the 110% non-craftsman must pay to the Treasure Manager obtain the item. The Treasure Manager will then give the character a tag for their product.

A player may never charge in-game money for an out-of-game physical representation of the commodity, but may charge out-of-game money for it.

*For example, Juno the Baker wishes to sell her brownies in-game. The player pays the production cost to treasure and receives her tags. Now she can charge the going rate of 1 cp and \$0.50 per brownie, she may not charge extra in-game money for the actual brownie.*

The list of approved craftsman skills is listed below. If a character wishes to have a skill not listed below the new skill must be approved by the normal process of adding a new skill to the game.

Craftsman Skill	Description
Brewer	Allows the character to make any flavor of beer, ale, or lager.
Vintner	Allows the character to make any flavor of wine, mead, or sparkling wine.
Distiller	Allows the character to make any flavor of brandy, whiskey, or hard spirit
Cook	Allows the character to make any kind of food including desserts and candy.
Gem Cutter	Allows the character to cut a gem into two gems of any value each with a combined worth of 10% less than the original. Each time a gem is cut, the total value is reduced by 10%.
Jeweler	Allows the character to combine refined metals and/or gems into jewelry. There is no net increase in the value of the piece of jewelry. Costume jewelry or jewelry with no in-game intrinsic value can be made for free.

For a player's character, there is never any net profit in making any of the above commodities; the raw material cost is the intrinsic value of the product. It is assumed the character does not have the time, resources or production facilities to make profitable merchandise.

### Create Golem

**Build Cost:** 2 per Rank                      **Purchase:** Multi  
**Tagged:** No                      **Duration:** Constant  
**Skill Type:** Arcane  
**Prerequisites:** Embalming, Two Rank 5 of Potions, Poisons, or Solutions  
**Skill List:** Alchemist

This skill allows the character to create golems. Create Golem Rank 1 allows the character to identify golems and other types of automatons after 1 minute of examination.

For the full rules on how to create golems and how they work in-game, see Chapter 4.

**Create Scroll**

<b>Build Cost:</b>	5	<b>Purchase:</b>	Once
<b>Tagged:</b>	No	<b>Duration:</b>	Constant
<b>Skill Type:</b>	Arcane		
<b>Prerequisites:</b>	Read Magic		
<b>Skill List:</b>	Sorcerer		

This skill allows the character to create Scrolls. For the complete rules on creating scrolls in-game, see the beginning of the Sorcery Advanced Career in Chapter 4.

**Note, all scrolls are written in the Magic language with English characters.**

**Critical Attack**

<b>Build Cost:</b>	5/10	<b>Purchase:</b>	Multi
<b>Tagged:</b>	Yes	<b>Duration:</b>	Instant
<b>Skill Type:</b>	Martial		
<b>Prerequisites:</b>	Any Weapon Skill		
<b>Skill List:</b>	Warrior Basic Career Skill List		

This skill doubles the total damage – Base Damage, Damage Bonus, Strength Bonus, alchemy, etc. – done by a weapon for one attack. This skill is not weapon or hand specific and can be used with any weapon the character has an appropriate Weapon Skill for. This skill **cannot** be combined with itself ever. The player should suffix the damage they call with the word “Crit”.

*For example, Corvale has Weapon Proficiency +3 with One-Handed Edge weapons. Additionally, he uses a +3 Giant Strength potion and a Giant Strength spell giving him a +6 Strength Bonus for one swing. The sword he is using has been enchanted for magical elemental fire with a Damage Bonus of +1. All together he would swing “12 Magic Fire” but he decides to use his Critical Attack skill and now he would call “24 Magic Fire Crit” for one attack.*

Additionally, the character can use his Critical Attack skill to block one martial attack which can either be damage, Critical Attack, Disarm, Stunning Blow, or Critical Backstab skills. The character may block ranged physical attacks but not those that have been used with the True Aim skill. Faith skills, spells or abilities cannot be blocked or stopped with this skill.

A character can use this skill to parry even if it is delivered from behind, but not if from a surprise attack; therefore it is impossible to parry the Waylay skill. It is also possible to parry an attack directed against someone else as long as they are within weapons length.

The character can choose to block a spell with this skill for another person; however they will take the effect of the spell and must call the appropriate defense against spells if they wish not to take the spell’s effect. The character may not block a spell that has been augmented with the Perfect Aim skill.

To use this skill as a parry the player should call “Crit Parry”.

When this skill is used offensively, it is not used if the character misses their target or the attack is blocked. If they succeed in striking their target or if the target calls an appropriate defense, the skill is used. This skill is always used once used to parry an attack. This skill does not double any additional damage from the Heal Wounds skill, Wounding skill, or Elemental Pool Points.

**Critical Backstab**

<b>Build Cost:</b>	3	<b>Purchase:</b>	Multi
<b>Tagged:</b>	Yes	<b>Duration:</b>	Instant
<b>Skill Type:</b>	Dexterity		
<b>Prerequisites:</b>	Rogue Basic Career Skill List, 2 Backstabs		
<b>Skill List:</b>	Master Thief		

This skill allows the character to double their weapon damage for one swing when attacking from behind. The player should double the amount of damage their character is swinging including base weapon damage, Damage Bonus, Strength Bonus, alchemical affects or magic bonuses. The character must be approximately 90 degrees behind their target to be considered behind them. The character cannot reach their arms around the target to use their Critical Backstab skill. A Critical Backstab does not have to be delivered from surprise. This skill can be used with the Waylay skill to double the damage of the Waylay skill. The player should suffix the damage they call with the word “Crit”.

This skill is not used if the character misses their target or the attack is blocked. If they succeed in striking their target or if the target calls an appropriate defense, the skill is used.

This skill does not double any additional damage from the Heal Wounds skill, Wounding skill, or Elemental Pool Points.

**D****Dark Blessing**

<b>Build Cost:</b>	3	<b>Purchase:</b>	Multi
<b>Tagged:</b>	Yes	<b>Duration:</b>	10 Minutes
<b>Skill Type:</b>	Faith		
<b>Prerequisites:</b>	2 Wounding Skill Purchases		
<b>Skill List:</b>	Servant of Darkness		

This skill allows the character to bless Servants of Darkness, Dark Acolytes, and non-mortal beings of evil (such as Hierarchs, Demons, and undead) with a +1 Strength Bonus and immunity to fear. This skill is non-latent and will last for 10 minutes from time of blessing. If this skill is used on an unaligned person, a Follower of Light or a being of good, the skill is used but it will have no effect. This skill cannot be stacked with itself, but will stack with other Strength Bonuses.

This skill requires the use of the character’s focus and a verbal, which must be at least 5 syllables, not including the skill’s name, and must contain some reasonably recognizable version of the name of the skill.

**Dark Cleric**

<b>Build Cost:</b>	3	<b>Purchase:</b>	Once
<b>Tagged:</b>	No	<b>Duration:</b>	Constant
<b>Skill Type:</b>	Faith		
<b>Prerequisites:</b>	Plot Approval		
<b>Skill List:</b>	Servant of Darkness		

This skill grants the character a limited immunity to necromancy. The character is immune to any undead creation spell in the Necromancy School. Damaging spells from that school still effect the character normally and a *Death Slave* spell will bring the character to the Brink of Death. Undead creating sorcery rituals affect the character normally.

**Dark Paladin**

<b>Build Cost:</b>	2	<b>Purchase:</b>	Once
<b>Tagged:</b>	No	<b>Duration:</b>	Constant
<b>Skill Type:</b>	Faith		
<b>Prerequisites:</b>	Plot Approval, Cleric of Darkness		
<b>Skill List:</b>	Servant of Darkness		

This skill makes the character permanently immune to all fear affects.

This skill can be purchased in the same month as the Dark Cleric skill.

**Dark Sorcerer**

<b>Build Cost:</b>	3	<b>Purchase:</b>	Once
<b>Tagged:</b>	No	<b>Duration:</b>	Constant
<b>Skill Type:</b>	Faith		
<b>Prerequisites:</b>	Plot Approval, Rank 3 Sorcery		
<b>Skill List:</b>	Servant of Darkness		

This skill allows the character to cast dark only rituals, gives the character a +5% Casting Bonus to all dark and dark only rituals and doubles the caster and participants' Knowledge Bonus for ranks of Necromancy School known.

For more information, see the sections on the Servant of Darkness Advanced Career and Sorcerer Advanced Career.

**Darkwood Ranger**

<b>Build Cost:</b>	3	<b>Purchase:</b>	Once
<b>Tagged:</b>	No	<b>Duration:</b>	Constant
<b>Skill Type:</b>	Miscellaneous		
<b>Prerequisites:</b>	Tracking		
<b>Skill List:</b>	Master Miscellaneous Skill List		

This skill allows the character to move through the Darkwood Forest unmolested by its denizens by knowing the safe paths to travel and how not to alert the creatures that live there. If the character wishes, they can lead a group of no more than seven other characters safely through at one time.

It does not give the character any special knowledge of what might live in the forest or where anything in the forest is, just how to navigate safely through it.

The more intelligent, free willed creatures in the forest are not fooled and can choose to act when they see the character normally. Additionally, these Darkwood creatures do not take kindly to intruders and usually act to kill anyone with this skill they find wandering where they are not supposed to be.

**Death Touch**

<b>Build Cost:</b>	10	<b>Purchase:</b>	Multi
<b>Tagged:</b>	Yes	<b>Duration:</b>	Instant
<b>Skill Type:</b>	Faith		
<b>Prerequisites:</b>	Venom Touch		
<b>Skill List:</b>	Servant of Darkness		

This skill causes the targeted character to go the Brink of Death. Also, the Death Touch skill can be reversed to life any evil character – Servant of Evil, Greater Undead, any demon, etc. If used in this way, it takes 1 minute to invoke and the character falls unconscious for 10 minutes. Note, when this skill is used as a life effect, the target character does **not** stop their Death Count.

This skill requires the use of the character's focus and a verbal, which must be at least 5 syllables, not including the skill's name, and must

contain some reasonably recognizable version of the name of the skill. This skill can be delivered by touch or through a weapon. If delivered through a weapon, the targeted character must be struck, and unlike Channeled spells, weapons and shields will stop the attack. If the character misses their target or the target uses a martial skill to stop the attack, the skill is not used. If the attack is stopped by a Resist Evil or Life skill or a magical defense that stops physical attacks the skill is used.

**Decapitate**

<b>Build Cost:</b>	15	<b>Purchase:</b>	Multi
<b>Tagged:</b>	Yes	<b>Duration:</b>	Instant
<b>Skill Type:</b>	Martial		
<b>Prerequisites:</b>	2 Slays, Continuous +5 Strength Bonus		
<b>Skill List:</b>	None		

This skill works just like the Slay skill with the following exceptions. First the target character's head is severed and is assumed to land near the character's body. Second, the character is not Mortally Wounded, but is at the Brink of Death. Lastly, this skill cannot be used as a parry to an attack. The character must call "Decapitate" after the blow is delivered, followed by any special damage modifiers, such as "Magic", "Silver", etc.

This skill requires the character to have a +5 Strength Bonus to learn and use. This can either be a natural racial bonus or from some other source, such as a magic item. However, the Strength Bonus must be a continuous bonus, not one that has a duration or is invoked for a duration. Therefore, things such as a *Strength Potion* does not count towards this prerequisite.

**Destroy Lesser Undead**

<b>Build Cost:</b>	3	<b>Purchase:</b>	Multi
<b>Tagged:</b>	Yes	<b>Duration:</b>	Instant
<b>Skill Type:</b>	Faith		
<b>Prerequisites:</b>	Paladin, Detect Undead		
<b>Skill List:</b>	Follower of the Light		

This skill will destroy any lesser undead or lesser demon by touch or through a weapon. This skill can be blocked by a magical defense against physical attacks and the Destroy Lesser Undead skill is used. A martial parry skill will block the attack but the Destroy Lesser Undead skill is not used.

This skill requires the use of the character's focus and a verbal, which must be at least 5 syllables, not including the skill's name, and must contain some reasonably recognizable version of the name of the skill.

**Destroy Undead**

<b>Build Cost:</b>	7	<b>Purchase:</b>	Multi
<b>Tagged:</b>	Yes	<b>Duration:</b>	Instant
<b>Skill Type:</b>	Faith		
<b>Prerequisites:</b>	Destroy Lesser Undead		
<b>Skill List:</b>	Follower of the Light		

This skill will destroy any undead or demon of any type by touch or through a weapon. The targeted character is completely destroyed and turns to dust if corporeal or vanishes if non-corporeal. Demons or Hierarchs are brought to the Brink of Death and instantly banished to their home plane leaving their worldly possessions behind. The Paladin is brought to the Brink of Death after successful use of this skill.

Unlike other skills, this skill is not used if it is stopped by any defense that stops physical attacks and the Paladin suffers no ill



effects. If stopped by an Empowerment skill, this skill is used and the Paladin suffers no ill affects. However, if this skill is blocked by an innate Resist ability, the skill is used and the Paladin is brought to the Brink of Death.

This skill requires the use of the character's focus and a verbal, which must be at least 5 syllables, not including the skill's name, and must contain some reasonably recognizable version of the name of the skill.

### Detect Lie

<b>Build Cost:</b>	3	<b>Purchase:</b>	Multi
<b>Tagged:</b>	Yes	<b>Duration:</b>	Instant
<b>Skill Type:</b>	Faith		
<b>Prerequisites:</b>	Cleric		
<b>Skill List:</b>	Follower of the Light		

This skill will test the veracity of the last statement made by another character. To use this skill, the character should call a Hold, privately ask the target player if they are lying, then call the Lay On. The skill is undetectable in-game to bystanders and the target character. However, a character with the Lie skill can use their skill as a defense. This is the only defense to this skill.

The veracity of the statement is based on what the player, not the character, knows is the truth. Therefore, if the character is intentionally lying or lying under compulsion (charm effect, *Forget and Remember* poison, etc), they are lying and will detect as such. Even if the character's perception of the truth is skewed, the skill will detect the statement as a lie.

*For example, a character does not believe it is murder to kill Halflings. After killing Kay, Scanlon asks the character if they killed Kay. The character says no, and Scanlon uses his Detect Lie skill to test the truthfulness of the statement. While the character does not believe killing Halflings is murder, the player must tell Scanlon that he is lying.*

The player should not draw upon out-of-game knowledge their character should not know about when judging the truthfulness of their answer.

*For example, Susan helped a Plot Marshal set up an ambush down the road. The marshal decides to make her the bait, an innocent farmer's wife who is being chased by a Lesser Troll the brigands have dominated. The farmer's wife screams for help and Calandris and his friends hear the call for help and investigate. Calandris asks the farmer's wife if this is a trap, and she answers no. Calandris uses his Detect Lie skill and learns the farmer's wife is not lying. While Susan knows there is a trap planned for the characters, her NPC is ignorant of the trick.*

If a character is lied to and later tells people the lie believing it to be the truth, he will not detect as lying.

*For example, while on an adventure Constantine meets a Dark Paladin who says he killed Squire Scanlon and shows him is tabard. Believing the Dark Paladin, Constantine runs to Avalon to get help. Suspecting this may be a trap, Juhani uses her Detect Lie skill to test the veracity of his statement. The skill reveals Constantine is not*

*lying and they go off to find the Dark Paladin. Along the way they meet Squire Scanlon who is alive and well and is looking for his missing tabard.*

In the above example, Constantine was not attempting to lie to Juhani, even though he was wrong and Squire Scanlon was alive, the skill still revealed he was telling the truth.

This skill requires no verbal to use.

### Detect Undead

<b>Build Cost:</b>	3	<b>Purchase:</b>	Multi
<b>Tagged:</b>	Yes	<b>Duration:</b>	Instant
<b>Skill Type:</b>	Faith		
<b>Prerequisites:</b>	Cleric		
<b>Skill List:</b>	Follower of the Light		

This skill allows the character to sense if another character is undead, demonic, draconic, or other higher power by looking at them. This skill can only be stopped by the Cloak Undead skill. If used against a character who is currently possessed, this skill will reveal this fact and the nature of the possessing character.

This skill requires the use of the character's focus and a verbal, which must be at least 5 syllables, not including the skill's name, and must contain some reasonably recognizable version of the name of the skill.

### Disarm

<b>Build Cost:</b>	4/8	<b>Purchase:</b>	Multi
<b>Tagged:</b>	Yes	<b>Duration:</b>	5 Seconds
<b>Skill Type:</b>	Martial		
<b>Prerequisites:</b>	Any Weapon Skill ~ or ~ Master Assassin		
<b>Skill List:</b>	Warrior Basic Career Skill List, Assassin		

A character can use this skill to disarm another character's weapon or any other item held in that arm. If the target character is using a one-handed edge or smaller weapon then the character can strike the targets arm or weapon, but if the character is using a bastard or two handed weapon then they must strike **one** arm to disarm the opponent. The character must call "Disarm" after the blow is delivered followed by any special damage modifiers, such as "Magic", "Silver", etc.

A character that has been disarmed must drop what is in that arm and cannot use that arm for 5 seconds. They cannot pick up their weapon nor do any other in-game action with that arm for 5 seconds. The character should drop their weapon at their feet; they cannot throw the weapon behind them or to another character.

If the item in the character's hand is attuned to the character, then the character does not have to drop the item, but they still cannot use that arm for the full 5 seconds. An *Attachment* spell or a *Paste of Stickiness* will not prevent the character from losing the weapon in their hand.

This skill can be used with ranged attacks. The character must still hit the arms to disarm someone. If the True Aim skill is used, then it is assumed to hit where needed to disarm an opponent.

Shields cannot be disarmed if wielded, but if the character is simply holding the shield then it can be disarmed by striking that arm.

This skill can be used to parry a Disarm skill. It cannot be used to parry any other martial attack or for another character. The character should call “Retain” when they use this skill to stop a disarm attempt.

When this skill is used offensively, it is not used if the character misses their target or the attack is blocked. If they succeed in striking their target or if the target calls an appropriate defense the skill is used. This skill is always used once used to parry a Disarm skill.

### Disarm Trap

<b>Build Cost:</b>	2/6	<b>Purchase:</b>	Once
<b>Tagged:</b>	No	<b>Duration:</b>	Constant
<b>Skill Type:</b>	Dexterity		
<b>Prerequisites:</b>	None		
<b>Skill List:</b>	Rogue Basic Career Skill List		

With this skill, a character may attempt to disarm traps the character comes across while playing the game. This skill does not allow the character to automatically disarm a trap, the player must actually disarm the trap they find during game play.

Without this skill, any character that attempts to disarm a trap will automatically set it off, even if the player successfully disarmed the trap. Any character can detect any trap they can see in-game; this skill is not required to detect traps.

### Dissection

<b>Build Cost:</b>	5	<b>Purchase:</b>	Once
<b>Tagged:</b>	No	<b>Duration:</b>	Constant
<b>Skill Type:</b>	Arcane		
<b>Prerequisites:</b>	Alchemy Lore ~ or ~ Sorcery Lore		
<b>Skill List:</b>	Alchemist, Sorcerer		

This skill allows the character to take and preserve a body part from a dead or immobile character. Using this skill takes 1 minute and the character should roleplay cutting or removing the body part as appropriate. Additionally, the character needs to use a dissection knife to use this skill; no other tools or items can be used.

Normally, any body part taken from a character dissipates after 5 minutes. However, if the body part was removed and preserved by someone with the Dissection skill, the body part does not dissipate. If the character is healed or resurrected, the character is whole and intact even if a portion of its body is preserved elsewhere.

When you start to remove an internal organ, bones or blood, you deliver a Killing Blow in the first three seconds of starting the dissection. You cannot use First Aid, Battle Surgery, *Icy Preservation* spell, or other means that stop a Death Count while you are Dissecting a part from a character.

This skill allows a character to collect components from various characters. However, you can only collect the same component once from the same character per month.

*For example, Adriana needs the unwilling heart of a Paladin for her Dark Sorcery. She captures Rynn and dissects his heart, then casts a Life spell on him. She can take his heart again if she wishes but it would not be useable in her ritual; only the first heart is worth anything.*

Only one component can be taken from the same character per Event, regardless of how many characters are dissecting the body. If multiple characters dissect the same body, then the first one to finish is the only

one who gains a usable component. They could take the heart, muscles, or blood but only the first one finished would be a valid component.

This skill is used to extract components from a character. It can never be used to preserve a whole character or body. If a part is dissected that contains other components, those components are null and useless.

### Distraction

<b>Build Cost:</b>	4	<b>Purchase:</b>	Multi
<b>Tagged:</b>	Yes	<b>Duration:</b>	10 Seconds
<b>Skill Type:</b>	Dexterity		
<b>Prerequisites:</b>	Trap Dodge		
<b>Skill List:</b>	Master Thief		

This skill allows the character to distract another character for 10 seconds. While distracted, the character cannot take any offensive action or theft against the target character. The target character cannot be Killing Blowed. Should the distracted character be attacked or any violent action takes place within 10 feet of them the character is no longer distracted.

The targeted character should roleplay being distracted by something for the duration of this skill.

To use this skill the character needs to hit the target character with a spell packet and call “Distraction”. This skill cannot be combined with the True Aim skill. This charm like skill can be stopped by an Iron Will or a use of the Hypnosis skill used defensively. This is not stopped by martial or magical defenses that stop physical attacks. The target of this skill is aware that they have been distracted by the character.

### Divination

<b>Build Cost:</b>	3	<b>Purchase:</b>	Once
<b>Tagged:</b>	No	<b>Duration:</b>	Constant
<b>Skill Type:</b>	Arcane		
<b>Prerequisites:</b>	None		
<b>Skill List:</b>	Miscellaneous Skill List		

By taking 10 minutes of in-game roleplay, the character is able to see into the beyond and divine the fate of a character. This skill is rather unreliable, not all predictions come true and those that do, rarely the way the characters expected. Once the diviner is finished with their reading, they should write down their prediction on a sheet of paper and hand it to a Plot Marshal. The Plot Marshal, at their own discretion and under no obligation, may or may not act on the information and should they chose to act, they are under no obligation to use it the way the character would wish or think.

Knowing this skill allows the character to use any divination tools they wish to, for example: tarot cards, dice, bones, tea leaves, crystal balls, palm reading, etc.

### Dodge

<b>Build Cost:</b>	10	<b>Purchase:</b>	Multi
<b>Tagged:</b>	Yes	<b>Duration:</b>	Instant
<b>Skill Type:</b>	Dexterity		
<b>Prerequisites:</b>	Rogue Basic Career Skill List, 4 Unique Dexterity Skills		
<b>Skill List:</b>	Assassin, Master Thief		

This skill will allow a character to avoid any one magical or physical attack, even from surprise. If the attack is an area affect attack, this skill does not allow the character to move to avoid the area of affect.

The character may dodge an attack even while encumbered, for example when carrying a body or other heavy items. The character may also dodge when blinded or unable to see the attacker or the attack. However, the character cannot dodge an attack if they are immobilized in any way, or if they intentionally touch or pick up an item or person. This includes areas or parts of a structure that a character intentionally touches. A character is considered immobile if they are affected by a *Pin, Bind, Paralysis, Imprisonment* spell or similar effect or if they are held by another character. A character in a *Magic Sanctuary* spell must drop the sanctuary in order to dodge.

The character must call “Dodge” when they use this skill. This skill is always used once called.

### Double Cast

<b>Build Cost:</b>	5	<b>Purchase:</b>	Multi
<b>Tagged:</b>	Yes	<b>Duration:</b>	Instant
<b>Skill Type:</b>	Arcane		
<b>Prerequisites:</b>	Any 3 Warlock Skills		
<b>Skill List:</b>	Warlock		

This skill allows a character to cast two identical spells at the same time. The caster must pay the Power Point cost for each spell and use two purchases of every Warlock skill they use in the casting. However the character only needs one use of the Speed Cast skill. The caster must use both hands within the normal 5 second limit after saying the verbal; the spell packets do not have to be thrown simultaneously, and the caster may transfer a spell packet from one hand to another during this time. It is not possible to augment only one of the spells with a Warlock skill. This skill can only be used with a spell cast by the character and not when invoked from an item or read from a scroll.

One defense that stops spells must be used for each spell, even if both spells are directed against the same target. This is true even when using a Dodge skill to stop the attack.

*For example, Lascula is fighting some Sea Elves and one of them attacks him, casting a spell “With Perfect Aim, Double Cast Death Slave Spell”. Lascula calls “Dodge, Dodge” and moves behind a large rock. The Warlock can no longer see him. After the fight, the players hand over their tags and Lascula needs to give two Dodge skill tags, one for each of the Death Slave spells cast at him with the Double Cast skill.*

To use this skill, the caster must have nothing but a spell packet in each hand, and prefix the spell verbal with “Double Cast...”

### Double Power

<b>Build Cost:</b>	5	<b>Purchase:</b>	Multi
<b>Tagged:</b>	Yes	<b>Duration:</b>	Instant
<b>Skill Type:</b>	Arcane		
<b>Prerequisites:</b>	Any 3 Warlock Skills		
<b>Skill List:</b>	Warlock		

This skill allows the character to double the numerical effect of either: twice the damage, twice the size, or twice the effect of any spell. This does not change the cost in Power Points of the spell. For example, a Double Power *Dragon’s Breath* spell would do 64 points of magical fire damage and cost 8 Power Points. This skill can only be used with a spell cast by the character and not when invoked from an item or read from a scroll.

For the spell to be doubled, it must involve a numeric quantity. For example: Double Power *Armor* spell grants 6 points of armor,

Double Power *Fortitude* spell has an 8 Threshold, Double Power *Blast* spell would destroy a door twice as large, a Double Power *Wall of Force* spell would be 20 feet by 20 feet, a Double Power *Lock* spell would require a Strength Bonus of +6, etc. This skill does not increase the duration or number of uses of a spell.

The use of this skill is indicated by prefixing the spell verbal by “Double Power...”

### Druid

<b>Build Cost:</b>	5	<b>Purchase:</b>	Once
<b>Tagged:</b>	No	<b>Duration:</b>	Constant
<b>Skill Type:</b>	Faith		
<b>Prerequisites:</b>	Herbal Lore, Requires Plot Approval		
<b>Skill List:</b>	Druid		

This skill makes the character a Druid and gives the character access to the Druid Advanced Career Skill List.

With this skill, the character gains a limited immunity to necromancy. The character is immune to any undead creation spell in the Necromancy School. Damaging spells from that school still effects the character normally and a *Death Slave* spell effects the character as a *Kill* spell would. Undead creating sorcery rituals effect the character, but they are at half power, in other words, half the normal Body Points, Power Points, Strength Bonus, skills, etc. and is wracked with constant pain and agony.

This skill also allows the Druid to communicate with animals and plants at will. The Druid’s words are understandable to the people around them, but the responses from the plant or animal are not. The animals or plants are not automatically friendly or benevolent towards the Druid.

This ability will work on some “monsters” that are natural creations of the Mother. The player must learn about these in-game. For plants or animals not played by an NPC, a Marshal is required to use this skill. If none is available, the plant or animal has nothing to say.

### Dwarven Resist

<b>Build Cost:</b>	3	<b>Purchase:</b>	Multi
<b>Tagged:</b>	Yes	<b>Duration:</b>	Instant
<b>Skill Type:</b>	Racial		
<b>Prerequisites:</b>	None		
<b>Skill List:</b>	None		

This skill will stop any poison or disease that affects the character.

This skill is not latent and the character has to call this skill when they are affected by a poison or disease. If a character has another defense against the effect they must call their Dwarven Resist skill first. If a character is out of Dwarven Resist skill uses for that Tag Cycle they do not have to call another defense against the poison or disease effect.

The character must call “Dwarven Resist” when they use this skill. This skill will not work if the character is unconscious.

## E

## Echo

<b>Build Cost:</b>	6	<b>Purchase:</b>	Multi
<b>Tagged:</b>	Yes	<b>Duration:</b>	10 Minutes
<b>Skill Type:</b>	Arcane		
<b>Prerequisites:</b>	Spell Singing Rank 3		
<b>Skill List:</b>	Spell Singer		

By means of this skill, the Spell Singer is able to change the duration of any spell song from “While Sung” to “10 Minutes”.

For this skill, the Spell Singer must create two lines that are prefixed to the Spell Singer’s song they want to Echo. When the song is completed the player should call the name of the song and “Echo”. For example, if the character is using Echo on their *Sleep* song, the player would call “Sleep Echo”.

## Elemental Attunement

<b>Build Cost:</b>	4	<b>Purchase:</b>	<i>Special</i>
<b>Tagged:</b>	No	<b>Duration:</b>	Constant
<b>Skill Type:</b>	Faith		
<b>Prerequisites:</b>	2 Elemental Pool		
<b>Skill List:</b>	Druid		

When the character learns the Elemental Pool skill, they gain one element of their choice that they can use with their pool. This skill allows them to attune themselves to one new element each time this skill is purchased.

This skill can only be purchased five times. Also, each purchase of this skill counts as a new master level skill.

## Elemental Pool Points

<b>Build Cost:</b>	5	<b>Purchase:</b>	Multi
<b>Tagged:</b>	Yes	<b>Duration:</b>	Instant
<b>Skill Type:</b>	Faith		
<b>Prerequisites:</b>	Druid		
<b>Skill List:</b>	Druid		

Once this skill is purchased, the character gains an Elemental Pool. For each purchase of this skill, the character gains 20 Elemental Pool Points. The character may use this to deal magical damage of the type given in the table below. The character must choose one element from the table below when the skill is purchased. Later, the character can learn the Elemental Attunement skill to learn to wield more elements from the table below.

Element	Opposite	Effect
Air	Earth	Lightning Damage
Earth	Air	Earth Damage
Fire	Water	Fire Damage
Water	Fire	Ice Damage
Life	Death	Healing Damage
Death	Life	Body Damage

The character may use this pool to throw the elemental damage at a rate of one EPP for one point of damage up to the maximum of the character’s current pool total. The character may use this skill to increase the damage of their weapon strikes in addition to changing the type of damage to the element called upon. The character may

use any amount of their available Elemental Pool to increase their damage on a one for one basis.

*For example, Kjellian is fighting a pack of undead that is normally only affected by silver weapons or better and some trolls. Having only normal weapons and swinging 3 points of damage, he uses seven points of his Elemental Pool with each swing calling upon elemental Life when striking the undead and elemental Fire when attacking the Trolls. He now swings 10 points of damage and calls “10 Magic Fire” or “10 Magic Life”. Kjellian can use more of his Elemental Pool with each attack to increase his damage accordingly.*

The character can also use their Elemental Pool to protect themselves and others from an elemental attack. The character can place a latent Elemental Protection that will stop any one elemental attack on a character for 15 EPPs. It will stop any elemental damage – even one augmented by a Warlock skill or damage suffixed with “Eldritch”, any spell from an elemental school, or damage from a physical elemental attack. The defense will not stop effects from physical attacks, for example: Slay, Assassinates, Disarms, Stuns (but it does stop the damage), etc. The Druid does not need to specify what the element is when the protection is granted and the Elemental Protection does not stack with itself.

Finally, the Druid may cast Nature Magic from their Elemental Pool in addition to no normal Power Points. It costs a number of EPPs equal to twice the listed Power Point cost.

This skill requires the use of a verbal, which must be at least 5 syllables, not including the skill’s name, and must contain some reasonably recognizable version of the name of the skill. Additionally the character **must** include the element called upon in the verbal when used as an attack. This skill can be delivered by touch or through a weapon. If delivered through a weapon, the targeted character must be struck, and unlike Channeled spells, weapons and shields will stop the attack. If the character misses their target or the target uses a martial skill to stop the attack, the skill is not used.

## Elemental Quintessence

<b>Build Cost:</b>	10	<b>Purchase:</b>	Once
<b>Tagged:</b>	Yes	<b>Duration:</b>	1 Hour
<b>Skill Type:</b>	Faith		
<b>Prerequisites:</b>	Nature Magic Rank 3		
<b>Skill List:</b>	Druid		

When this skill is purchased, the character embraces the elemental power of nature and gains the ability to call upon one element (chosen when the skill is purchased) and merge with it, transforming their body into a partial elemental. All armor and items worn are unchanged in the new form.

When a character transforms, they must drop to their hands and knees for 1 minute to roleplay the shift. During this time, the character puts on the appropriate costuming for the elemental which must at least be a mask and a tabard. The character can be attacked and harmed during this time and no skills or abilities can be used. The Druid may call latent spell defenses or invoke spell defenses from items, however. Taking damage will not interrupt the transformation unless the Druid is rendered unconscious or worse. If the character is interrupted, they do not use the skill for that Tag Cycle.

When transformed, the Druid gains the following abilities:



- +20 Elemental Pool Points
- Deals 2 points of damage for each EPP used when using their embraced element.
- Claws always swing the embraced element and magic
- One special ability from the table below
- Immunity to all charm effects
- Immunity to Fear

They also suffer the following detriments while shape shifted:

- The character becomes somewhat non-corporeal and loses the ability to wield weapons or shields.

Element	Special Ability
Air	<i>Thunder and Lightning</i> x3
Earth	<i>Flesh to Stone/Stone to Flesh</i> x2
Fire	Total Power <i>Lava Burst</i> x2
Water	<i>Arctic Wind</i> x3
Life	Elemental Life x2
Death	Elemental Death x2

For air, earth, fire, an water, the abilities are stopped by defenses that stop spells (including absorption which gives the appropriate Power Points). For life and death, the abilities are physical effects and are stopped by any magical defense that stops a physical attack. The abilities require no verbals and the player should suffix the spell effects with the word "...Spell".

While in their quintessence form, the character appears as their character with aspects of the element. The character gains no special movement powers.

The change normally lasts 1 hour, but the character may change back to their natural form at will. If while in the quintessence form, the character is brought to the Brink of Death, they are forced back into their natural form.

This skill requires the use of the character's focus and a verbal, which must be at least 5 syllables, not including the skill's name, and must contain some reasonably recognizable version of the name of the skill.

**The character may only purchase Aspect of the Beast or Elemental Quintessence, not both. Once learned this skill cannot be unlearned in order to purchase the other skill.**

### Elven Resist

**Build Cost:** 3                      **Purchase:** Multi  
**Tagged:** Yes                      **Duration:** Instant  
**Skill Type:** Racial  
**Prerequisites:** None  
**Skill List:** None

This skill will stop the following charm effects: any Charm School spell even if augmented with the Total Power skill, any charm effect Spell Song, any charm effect Nature Magic spell, sorcery charm effect and friendship charm effects. This skill will not stop the Hypnosis skill, Vampiric Domination, alchemical items, demonic charms or draconic Charms.

This skill is not latent and the character has to call this skill when they are affected by one of the listed effects. If a character has another defense against the charm effect they must call their Elven Resist skill first. If a character is out of Elven Resist skill uses for that Tag Cycle they do not have to call another defense against the charm affect.

This skill will not work if the character is unconscious.

### Embalming

**Build Cost:** 2                      **Purchase:** Once  
**Tagged:** No                      **Duration:** *Special*  
**Skill Type:** Arcane  
**Prerequisites:** Alchemy Lore, Dissection  
**Skill List:** Alchemist

By use of this skill, the character is able to permanently preserve a corpse whole unlike Dissection, which only allows a character to preserve only parts of a creature. The body does not dissipate while it is being embalmed. The body can still be healed from the Brink of Death by the usual means, embalming does not end a character's Death Count. Body parts of an Embalmed creature cannot be used as components except for golem creation.

In order to use this skill, the body must be at the Brink of Death or Dead, the character must use Embalming Oil, and take 5 minutes in-game.

### Empower Evil

**Build Cost:** 5                      **Purchase:** Multi  
**Tagged:** Yes                      **Duration:** Latent  
**Skill Type:** Faith  
**Prerequisites:** Dark Paladin, Compel Greater Undead  
**Skill List:** Servant of Darkness

This skill allows the character to empower an intelligent lesser undead, a greater undead, any demon, or a Servant of Darkness to resist one Follower of the Light destroy skill, turn skill, Heal Wounds skill, or Heal Life skill. Additionally the Empower Evil skill will stop one Servant of Darkness Pain skill, Envenom skill, Death Touch skill, control skill, or Wounding skill. Empower Evil is latent and non-stackable.

This skill requires the use of the character's focus and a verbal which must be at least 5 syllables not including the skills name and must contain the name of the skill.

The character must call "Empower Evil" when they invoke this skill.

### Escape

**Build Cost:** 4                      **Purchase:** Multi  
**Tagged:** Yes                      **Duration:** Instant  
**Skill Type:** Dexterity  
**Prerequisites:** Dodge  
**Skill List:** Assassin, Master Thief

This skill allows the character to skillfully escape from normal mundane bonds, restraints or ropes that bind their arms or legs. This skill will not allow the character to escape from magical or alchemical bindings, being held by another character, or being paralyzed. Only one use of this skill is needed to free both the character's arms and legs.

The character must call "Escape" when they use this skill. The player may, if they wish, call a hold to remove the bonds.

**Evaluate Item**

<b>Build Cost:</b>	3	<b>Purchase:</b>	Once
<b>Tagged:</b>	No	<b>Duration:</b>	Constant
<b>Skill Type:</b>	Miscellaneous		
<b>Prerequisites:</b>	None		
<b>Skill List:</b>	Miscellaneous Skill List		

After spending 1 minute in-game examining an item, the character can tell how much it is worth in-game. Every in-game LAIRE item has a number engraved on it. The character can consult an Evaluate Item List to determine its value. The character cannot tell if an item is magical or not, nor can they identify an alchemical item or component with this skill.

There is an out-of-game logistical limitation to this skill. If there is no Evaluate Item List available, the attempt fails.

**Evisceration**

<b>Build Cost:</b>	6	<b>Purchase:</b>	Once
<b>Tagged:</b>	No	<b>Duration:</b>	<i>Special</i>
<b>Skill Type:</b>	Arcane		
<b>Prerequisites:</b>	Battle Surgery, Autopsy, Dissection		
<b>Skill List:</b>	None		

This skill allows the character to painfully disfigure or alter certain body parts on an immobilized character without killing them. This causes pain until the character has been healed. Spells from the Healing School will undo the effects of this skill unless the user of this skill uses the appropriate amount of Moonwater to create an aberration. Any character with this skill can undo any Evisceration performed by another character without the aid of magic, but Sunwater is still necessary to undo an aberration. Characters with the Evisceration skill or Rank 1 Solutions skill can recognize the presence of Moonwater and in what quantity it appears on the character.

Acts of Evisceration are limited by what can be roleplayed in-game or represented through props and make-up. A character cannot, for example, reattach someone's legs on backwards and expect them to walk. Such extreme acts render limbs useless and cause pain, nothing more. Evisceration does allow the user of the skill to open up a character as if surgery were being performed. Limbs and minor organs can be removed. Characters can be impaled and other extreme forms of torture can be used. This skill does not allow the user to remove or damage the most vital organs (heart, lungs, etc.) Such acts render an immediate Killing Blow. This skill also does not allow the user to seamlessly transplant body parts with other characters. There are additional requirements and limits to Grafting and these are described below.

To create an aberration, a Plot Marshal must approve the creation of any aberration. The character needs to spend 30 minutes in-game roleplaying this skill and use the amount of Moonwater listed in the table below. The character must fill out an Aberration Card (obtained from Plot) detailing the injuries that have been inflicted and the dosage of Moonwater used. This card must be approved and signed by a Plot Marshal and the target character must carry this card with them. A character can only work on one character at a time and only one character can use this skill on the target character at a time. The character must spend the full 30 minutes to use this skill. If they are interrupted or stop, the attempt fails and they must start over again from the beginning.

To cure an aberration, an equal amount of Sunwater must be used before the character can be healed. Alternatively, a character with the Heal Wounds skill can heal an aberration by using a number of Healing Pool Points equal to the amount of Moonwater used.

The types of aberrations the character can create and the amount of Moonwater needed are given in the table below. A character using more than the listed Moonwater has no additional affect.

Effect	Amount of Moonwater per Effect
Festering Wounds	8
Impaling	16
Lobotomy	24
Grafting	32

**Festering Wounds** leave open, unhealable wounds on the target character. Up to three Festering Wounds can be created on one character. Each Festering Wound lowers the characters Body Point total by 10%, rounded down.

A character can be **Impaled** by use of this skill. No object larger than a polearm can be used to impale the character. While impaled, the character is at half their Body Point total. If the impaled object is removed, the character is Mortally Wounded and can still be healed, however they will still be at half their Body Point total until properly healed.

**Lobotomizing** a character removes a portion of their brain. The target character is affected as if under an *Enfeeblement* spell. The target character's memories are never affected by use of the skill.

A character can **Graft** a body part from one character onto another. Extra limbs, such as a third arm or leg, cannot be added. Wings or tails added are vestigial and do not function. Physical racial abilities such as Claws or gills can be granted to the target character. Immunities, vulnerabilities, skills, powers, knowledge, etc., cannot be transferred. A maximum of a +1 Strength Bonus can be gained by use of this skill.

If an aberration dies and resurrects in the Healers Guild without their body, all aberrations are healed and the character resurrects normally.

**Extend Duration**

<b>Build Cost:</b>	5	<b>Purchase:</b>	Once
<b>Tagged:</b>	No	<b>Duration:</b>	Constant
<b>Skill Type:</b>	Arcane		
<b>Prerequisites:</b>	Alchemy Lore, Any One Rank 4 of Potions, Poisons, or Solutions		
<b>Skill List:</b>	Alchemist		

This skill allows the Alchemist to increase the duration of an alchemical item. This skill must be used at the time of creation and cannot be used after the alchemical item is made. Using this skill increases the number of Production Points and Reagent Tags needed. Below is a table that outlines these cost increases.

Time Increments	Extend Duration Table		
		Production Point Increase	Reagent Tag Increase
Instant			
10 Min	+1 Level	+50%	+50%
1 Hour	+2 Levels	+100%	+100%
6 Hours			
24 Hours			
1 Event			

*Note: "Level" refers to how many time increment increases you make. Going from 10 Min to 1 Hour is +1 Level; going to 6 Hours is +2 Levels.*

An alchemical item can never increase its duration by more than two levels and can never last longer than an Event. Whether this skill works on an alchemical item is noted in the item's description.

**Extend Spell Song**

<b>Build Cost:</b>	3	<b>Purchase:</b>	Once
<b>Tagged:</b>	No	<b>Duration:</b>	<i>Special</i>
<b>Skill Type:</b>	Arcane		
<b>Prerequisites:</b>	Spell Singing Rank 4		
<b>Skill List:</b>	Spell Singer		

This skill allows the character to extend the range of the *Heroism* song. In order to use this skill effectively, there must be other Spell Singers who can hear the song in the area. The character starts their song and calls “Extension” at the end, then any other Spell Singer who heard the song can then take up the song and extend its range. The Spell Singers must still be able to hear the originator of the song in order to continue extending it.

Should one of the Spell Singers move too far away and can no longer hear the originator, they may move back in range and take up the song again. Only characters with the Spell Singer skill can extend the song. If the originator should stop singing, the song ends for everyone.

**Extension**

<b>Build Cost:</b>	3	<b>Purchase:</b>	Multi
<b>Tagged:</b>	Yes	<b>Duration:</b>	5 Minutes
<b>Skill Type:</b>	Martial		
<b>Prerequisites:</b>	Channeling		
<b>Skill List:</b>	Master Warrior		

When the character invokes this skill, it will allow them to increase the duration for holding a spell they are going to channel from 5 seconds to 5 minutes. After the spell verbal is completed, the caster must still state the name of the spell every 5 to 10 seconds. The skill is used once the spell verbal is successfully completed. If the character takes damage or the 5 minutes are up, the spell is lost.

The verbal for this skill is “Extension” which must prefix the normal spell verbal. A character cannot use this skill with the Redirect skill, only spells they cast themselves can be extended.

**Feat of Strength**

<b>Build Cost:</b>	3	<b>Purchase:</b>	Multi
<b>Tagged:</b>	Yes	<b>Duration:</b>	Instant or 15 Seconds
<b>Skill Type:</b>	Martial		
<b>Prerequisites:</b>	Warrior Basic Career Skill List, 2 Staminas		
<b>Skill List:</b>	Master Warrior		

Using this skill gives the character a +3 Strength Bonus, Non-Combinable, allowing the character to perform a feat of great strength, adding 3 points of damage to one swing, performing an action such as carrying a body for 15 seconds, or similar actions.

This skill may be stacked with the *Giant Strength* spell, *Feat of Heroes* spell, any giant strength potion, or any other Strength Bonus.

Unlike any other type of Strength Bonuses, the Feat of Strength skill will stack with itself. So, if a character has three purchases of the skill he can increase his damage for one swing by 9 points of damage, or perform an action requiring a +9 Strength Bonus, Non-Combinable.

If this skill is used to increase the character’s damage, it is not used if they miss or the attack is blocked. If they succeed in striking their target or if the target calls an appropriate defense, the skill is used.

The character must call “Feat of Strength” when they use this skill.

**First Aid**

<b>Build Cost:</b>	2	<b>Purchase:</b>	Once
<b>Tagged:</b>	No	<b>Duration:</b>	Constant
<b>Skill Type:</b>	Miscellaneous		
<b>Prerequisites:</b>	None		
<b>Skill List:</b>	Miscellaneous Skill List		

This skill can be used to heal a living character that is Bleeding to Death. The character places two free hands on the target character and calls “First Aid” and begins a 1 minute count. Once a character starts to use this skill the target character’s Death Count stops. After the 1 minute count, the character is Unconscious at 0 Body Points and after 5 minutes will regain consciousness and be at 1 Body Point. Also, this skill can be used to wake up a character that is Unconscious and has more than 1 Body Point. The character should place a free hand on the target character and begin a 1 minute count. No Body Points are restored when using the First Aid Skill in this manner.

A character can only be first aided by one character at a time and a character can only first aid one character at a time. The use of this skill requires the character to concentrate while they are using this skill. The player should look at the character they are using this skill on and can only talk, invoke Latent spells, or use a Dodge skill while first aiding someone. If the use of this skill is interrupted by either taking damage or the character choosing to stop, the target character must resume their Death Count. If the character wishes to try to first aid again, they must start from the beginning.

A character can also use this skill to assess the condition of another character. The character places a free hand on the target character, says “First Aid Assess” and takes a 5 second count. Once the character starts to assess the condition of the target character, and if that character is Bleeding to Death, their Death Count stops. The character using this skill will learn what stage their Death Count is at and how many Body Points the target character is down.

This skill cannot be used to heal characters who are Mortally Wounded or at the Brink of Death.

A character can choose to use a real bandage when using this skill. The bandage is in-game, does not have to be purchased, must be white, and must be larger than 2 feet by 3 inches. The character must either have their hand on the target character or be bandaging to use this skill. If the character uses a bandage, the time it takes for the target character to wake up is cut in half – only taking 2½ minutes. Once the target character wakes up, the bandages are no longer needed and can be removed or returned to the first-aider to re-use.

**Florentine**

<b>Build Cost:</b>	3/9	<b>Purchase:</b>	Once
<b>Tagged:</b>	No	<b>Duration:</b>	Constant
<b>Skill Type:</b>	Martial		
<b>Prerequisites:</b>	Any One-Handed Weapon Skill		
<b>Skill List:</b>	Warrior Basic Career Skill List, Rogue Basic Career Skill List		

This skill allows the character to use a one handed weapon in one hand and a small weapon in the other. The character cannot use two one handed, any bastard, or any two handed weapons with this skill. The character must strike and call damage separately for each weapon. Any Strength Bonus the character has adds to the damage

of both hands, unless that Strength Bonus is for only one attack, then the character can only apply it to one hand and one attack.

### Forest Meld

**Build Cost:** 6                      **Purchase:** Multi  
**Tagged:** Yes                      **Duration:** *Special*  
**Skill Type:** Faith  
**Prerequisites:** Pass Without a Trace  
**Skill List:** Druid

For each use of this skill purchased, the character may become undetectable while standing next to a tree or shrub. Once invoked, the character may not move or speak or the effect is negated and the ability is used. To use this ability, the player stands next to a tree or shrub and crosses their hands or weapons over their head. This skill cannot be used while in combat.

This skill requires the use of the character's focus and a verbal, which must be at least 5 syllables, not including the skill's name, and must contain some reasonably recognizable version of the name of the skill.

## G

### Greater Magic Weapon

**Build Cost:** 5                      **Purchase:** Multi  
**Tagged:** Yes                      **Duration:** 30 Minutes  
**Skill Type:** Faith  
**Prerequisites:** Paladin  
    ~ or ~  
    Dark Paladin  
**Skill List:** Follower of the Light, Servant of Darkness

When invoked, this skill will empower any weapon the character holds to swing for magical damage for 30 minutes. This skill is hand specific and once invoked, only weapons in that hand will be augmented. There is no Damage Bonus or other effect from the use of this skill. The weapon can still be shattered.

This skill requires the use of the character's focus and a verbal, which must be at least 5 syllables, not including the skill's name, and must contain some reasonably recognizable version of the name of the skill.

### Gypsy Curse

**Build Cost:** 3                      **Purchase:** Once  
**Tagged:** No                      **Duration:** *Special*  
**Skill Type:** Racial  
**Prerequisites:** None  
**Skill List:** None

This skill allows the character to curse another character when they are killed. The curse is enacted when the character leaves their body after being at the Brink of Death. The player should announce the curse to the offending character and the effect is immediate. There is no defense to this skill except for the Resist ability.

The curse can be removed by the character or by a clan's leader. Otherwise, the character must find a way to remove the curse. As with other curses, this curse will stay with the character even if they are killed.

Below are the curses a character can use. They can choose a curse for their level or any lower level.

Character Level	Curse
1-4	Curse character to end every sentence with one word, chosen at time of curse. Curse character to kneel while they are speaking to a gypsy. Curse character to never use their hands to eat.
5-9	Curse character to always accept a bet, no more than 5sp wager. Curse character to always yell – as loud as they can – everything they say. Curse character to always walk in light. They must carry a light source as bright as a <i>Light</i> spell if it is dark. If there is no light present, they cannot move.
10-14	Curse character to always tell the full and complete truth. Curse character to be blind. Curse character to never be able to run.
15-19	Curse character to be unable to move unless there is another character in line of sight. Curse character to never refuse a request for help. Curse character to wither away, loosing 10%, rounded up, of their original Body Point total per month down to a minimum of 1 Body Point.
20-29	Curse character to take whatever damage they deal in hand to hand combat. Curse character to stutter, making them unable to use any skill that requires a verbal or cast spells. Curse character to take double damage from all forms of attacks, no effect on durations.
30+	Curse character to be brought to the Brink of Death before every dawn by any means plot devises. Curse character to never be able to hurt another character directly.

## H

### Heal Life

**Build Cost:** 10                      **Purchase:** Multi  
**Tagged:** Yes                      **Duration:** Instant  
**Skill Type:** Faith  
**Prerequisites:** 2 Heal Wounds  
**Skill List:** Follower of the Light

This skill allows the character to bring another character that is at the Brink of Death back to life at 1 Body Point without having to use the Death System. The character using this skill is rendered unconsciousness for 10 minutes with no way of being awoken.

This skill may also be used as an attack, either by touch or through a weapon, against undead only. It can also be used to block the Death Touch skill. Using the skill in either of these ways does not cause the character to fall unconscious.

This skill requires the use of the character's focus and a verbal, which must be at least 5 syllables, not including the skill's name, and must contain some reasonably recognizable version of the name of the



skill. This skill can be delivered by touch or through a weapon. If delivered through a weapon, the targeted character must be struck, and unlike Channeled spells, weapons and shields will stop the attack. If the character misses their target or the target uses a martial skill to stop the attack, the skill is not used. If the attack is stopped by an Empower skill or a magical defense that stops physical attacks, the skill is used.

**Heal Wounds**

**Build Cost:** 5                      **Purchase:** Multi  
**Tagged:** Yes                      **Duration:** Instant  
**Skill Type:** Faith  
**Prerequisites:** Cleric  
**Skill List:** Follower of the Light

Once this skill is purchased, the character gains a Healing Pool. For each purchase of this skill, the character gains 25 Healing Points. The character may use this to heal any character’s Body Points at a rate of one for one or harm undead characters at the same rate. The character may also use their pool to mimic Healing School spells at double the Power Point cost and by touch only. The table below outlines what spells they can mimic and how many Healing Pool Points it costs.

Healing Spell	Healing Pool Points
<i>Detect Life</i>	0*
<i>Purify Blood</i>	4
<i>Assess Ailment</i>	8
<i>Heal Body</i>	8
<i>Heal this Mind</i>	8
<i>Heal this Limb</i>	10
<i>Heal this Mortal Wound</i>	12
<i>Return Ghoul**</i>	16
<i>Return Death Slave**</i>	40

\* The character must have at least 1 Healing Pool Point to Detect Life.

\*\* Only Clerics can mimic these two effects, not Paladins.

The character may use this skill to augment their damage to “Light” which will deal direct body damage to all undead and demons and requires one point of their Healing Pool per attack. This does not increase the damage done by the attack. The character may use any amount of the Healing Pool they have left to deliver damage by touch or thrown via a spell packet. A character may not touch another character if they are engaged in combat.

*For example, Kida has three purchases of the Heal Wounds skill giving her 75 Healing Pool Points. She has used 20 Healing Pool Points already that Tag Cycle. She sees a demon pontificating to the Avalonians attempting to cower them into submission. She walks up behind the demon and touches the character using her Healing Pool to inflict damage. She says, “By the light of the sun I cleanse your evil taint with 30 Light”. The NPC demon takes 30 points of direct Body Point damage. Now Kida is engaged in combat and cannot touch the NPC. She uses her dagger to attack the demon. Normally she swings 1 damage with her dagger, but Kida has used a Holy Blessing and a +3 Strength Potion. She uses 1 point of her Healing Pool to augment her damage and now swings “5*

*Light” – 1 for the dagger, +1 for the Holy Blessing and +3 for the Giant Strength potion.*

The character that also has the Paladin skill may use this skill to increase the damage of their weapon strikes in addition to changing the type of damage to “Light”. The character may use any amount of their available Healing Pool to increase their damage on a one for one basis.

*For example, Reylos is fighting a pack of undead that is normally only affected by silver weapons or better. Having only normal weapons and swinging 7 points of damage, he uses three points of his Healing Pool with each swing. He now swings 10 points of damage and calls “10 Light”. Reylos can use more of his Healing Pool with each attack to increase his damage accordingly.*

Damage augmented with “Light”, in either case, does not harm living characters unless noted on their Character Card.

This skill requires the use of a verbal, which must be at least 5 syllables, not including the skill’s name, and must contain some reasonably recognizable version of the name of the skill. This skill can be delivered by touch, thrown, or through a weapon. If delivered through a weapon, the targeted character must be struck, and unlike Channeled spells, weapons and shields will stop the attack. If the character misses their target, no matter how it is delivered, or the target uses a martial skill to stop the attack, the skill is not used. If the attack is stopped by an Empower skill or a magical defense that stops physical attacks, the skill is used.



**Herbal Lore**

<b>Build Cost:</b>	3	<b>Purchase:</b>	Once
<b>Tagged:</b>	No	<b>Duration:</b>	Constant
<b>Skill Type:</b>	Miscellaneous		
<b>Prerequisites:</b>	None		
<b>Skill List:</b>	Miscellaneous Skill List		

This skill allows the character to identify and collect herbs during an Event. The player should go to the NPC Cabin and inform a marshal they are attempting to collect herbs. The player must then spend time in-game looking for herbs. The longer the character looks, the more likely it is they will find something. When the character finishes, they return to the NPC Cabin and a random roll will determine what the character finds.

With this skill, the character can bring in-game any common herb that they have a physical representation for. For example, the player brings in a pack of mint leaves from the supermarket and can ask the Treasure Manager to write them out the appropriate number of tags. The maximum amount of herbs a player can bring in is 1 silver piece worth per month.

**Hibernate**

<b>Build Cost:</b>	3	<b>Purchase:</b>	Once
<b>Tagged:</b>	No	<b>Duration:</b>	<i>Special</i>
<b>Skill Type:</b>	Faith		
<b>Prerequisites:</b>	Forest Meld		
<b>Skill List:</b>	Druid		

This skill allows the character to meld with nature and fall asleep for as long as the character wants, but:

- The time specified has to be longer than one week,
- The Duration has to be specified at the time the skill is used, and
- Has to be used in a natural surrounding.

While hibernating, the character is safe from all outside harm and cannot be found. The character does not need to eat, sleep or excrete. They do not age nor do they have any sense of the outside world or the passage of time.

If this skill is used between Events, the character does not need to pay their upkeep and cannot learn any new skills.

To use this skill, the character cannot be in danger of being attacked, engaged in combat, and must sit and meditate for 1 hour. This skill requires the use of the character's focus and a verbal, which must be at least 5 syllables, not including the skill's name, and must contain some reasonably recognizable version of the name of the skill.

**Holy Blessing**

<b>Build Cost:</b>	3	<b>Purchase:</b>	Multi
<b>Tagged:</b>	Yes	<b>Duration:</b>	10 Minutes
<b>Skill Type:</b>	Faith		
<b>Prerequisites:</b>	2 Heal Wounds		
<b>Skill List:</b>	Follower of the Light		

This skill allows the character to bless Followers of the Light, Acolytes, and non-mortal beings of good (such as Dragons, Drakes, and Solars) with a +1 Strength Bonus and immunity to fear. This skill is non-latent and will last for 10 minutes from time of blessing. If this skill is used on an unaligned person, a Servant of Evil, or a being of evil, the skill is used but it will have no effect. This skill cannot be stacked with itself, but will stack with other Strength Bonuses.

This skill requires the use of the character's focus and a verbal, which must be at least 5 syllables, not including the skill's name, and must contain some reasonably recognizable version of the name of the skill.

**Hypnosis**

<b>Build Cost:</b>	10	<b>Purchase:</b>	Multi
<b>Tagged:</b>	Yes	<b>Duration:</b>	30 Minutes
<b>Skill Type:</b>	Dexterity		
<b>Prerequisites:</b>	Master Assassin Skill		
<b>Skill List:</b>	Assassin		

This skill allows the character to hypnotize one targeted character that is within 10 feet and after making direct, mutual eye contact for 3 seconds. The in-game verbal, "I compel you with hypnosis", must be used after the 3 seconds of eye contact. If eye contact is broken before the verbal is finished, or the character takes damage the attempt fails and the skill is used.

Hypnosis and any Charm School spell or lesser racial ability – satyr/faun charm – are mutually inclusive. However, the hypnosis will override the commands of a lesser charm. For greater racial abilities – Vampiric Domination, Demonic or Draconic Charm – though also mutually inclusive, the hypnosis will be overridden by the greater racial charm.

The Iron Will skill or immunity to charms can block the Hypnosis skill. If the target also has a use of the Hypnosis skill, they may use that to block the attack. *Resist Suggestion* spell or Elven Resist skill will not work to stop this skill.

While the hypnosis is in effect, the character may give any number of commands to their target. The commands must be in a clear and understandable language. While hypnotized, the target character will not attack the character unless they are ordered to.

The targeted character will remember all the actions they took while hypnotized and believe them their own. They can be ordered to forget who hypnotized them – this is the only command that will last after the hypnosis ends. A second use of the Hypnosis skill will reveal this lost memory. The character can cause the target to forget or remember anything else they want; however, the affected character will remember the truth when the duration ends.

This skill lasts for 30 minutes. If while under the effects of a Hypnosis skill the target character is hypnotized, the newest hypnosis takes effect and the old one ends.

The hypnotized character does not know they are hypnotized while under the effects, nor when the affect ends. However, they may question why they took actions they would not normally or why they forget certain facts.

## J

**Identify Component**

<b>Build Cost:</b>	3	<b>Purchase:</b>	Once
<b>Tagged:</b>	No	<b>Duration:</b>	Constant
<b>Skill Type:</b>	Arcane		
<b>Prerequisites:</b>	Dissection		
<b>Skill List:</b>	Alchemist, Sorcerer		

This skill allows a character to identify components and what race a character is. It takes 1 minute to use this skill.

This skill will identify a component they find. They can verify what it is by cross-referencing the out-of-game number on the item tag with a component list.

The character may also identify the race of a character by examining them. This will not allow a character to identify a character from across a field or during combat for it is necessary to do a close examination of the creature to determine what type it is. The character need not be dead, just unresisting. They can, for example, tell what kind of troll they are examining, but not what skills or careers they might know. Without this skill, the character might know he has dissected a troll's blood, but not what kind of troll he is dissecting. If a character wants to know if the brain of the fallen character is a necromancer's brain, they would first have to dissect the brain then spend another minute in-game identifying the brain. A character cannot take a sample of un-dissected blood and tell whether the character is a Druid, Mage, Healer, or whatever. They can do so after dissecting the blood.

**Immunity to Charm**

<b>Build Cost:</b>	5	<b>Purchase:</b>	Multi
<b>Tagged:</b>	No	<b>Duration:</b>	Constant
<b>Skill Type:</b>	Faith		
<b>Prerequisites:</b>	Paladin ~ or ~ Dark Paladin		
<b>Skill List:</b>	Follower of the Light, Servant of Darkness		

This skill will allow the character to become completely and permanently immune to one specific charm or charm-like effect per purchase of this skill. Some of the charms that can be chosen are given below.

Charm Category	What is Stopped
Charm School Spell	That specific spell only
Domination	Any domination effect, spell, ritual or ability
Vampiric Charm	Any charm affect from Vampires
Demonic Charm	Any charm effect from any demon or Hierarch
Possession	Any possession effect from any type of character
Hypnosis	Any hypnosis effect from any skill or ability
Undead Control	Any skill or ritual that controls undead (not Faith skills)

A character may not use this skill to become immune to any alchemical affect, even if that effect is similar to the categories listed above. Additionally, a character may not become immune to any Follower of the Light or Servant of Darkness compel or turn skills.

**Inner Catalyst**

<b>Build Cost:</b>	0	<b>Purchase:</b>	Once
<b>Tagged:</b>	No	<b>Duration:</b>	Constant
<b>Skill Type:</b>	Arcane		
<b>Prerequisites:</b>	Rank 5 Potions		
<b>Skill List:</b>	Alchemist		

This Alchemist only skill allows the character to increase the duration of any potion they consume. The character is able to increase the duration by one level. This can extend the duration past what can normally be made. For example, if a character consumes a +3 *Giant Strength* potion with a duration of 1 hour, this skill would allow them to increase that duration to 6 hours.

This skill must be used when the alchemy is first consumed. The player cannot decide later they wish to increase the duration. This skill cannot be used to decrease the duration of a potion, even if they used this skill to increase the duration prior. The character must record their use of this skill on the alchemical item tag.

**Instructor**

<b>Build Cost:</b>	3	<b>Purchase:</b>	Once
<b>Tagged:</b>	No	<b>Duration:</b>	Constant
<b>Skill Type:</b>	Miscellaneous		
<b>Prerequisites:</b>	None		
<b>Skill List:</b>	Miscellaneous Skill List		

The character with this skill is particularly good at teaching others the things they know. Normally, it takes 5 minutes per Build Point to teach someone a new skill. The character with this skill takes only half that time. So to teach someone the Slay skill normally takes 50 minutes, but with the Instructor skill it will only take 25 minutes of in-game roleplay to teach.

This skill is cumulative with the Quick Study skill therefore, if the student has the Quick Study skill, it would only take 12½ minutes to teach the Slay skill.

This skill is not list or Teach skill specific and any skill the character knows can be taught quickly.

**Interrogate**

<b>Build Cost:</b>	3	<b>Purchase:</b>	Multi
<b>Tagged:</b>	Yes	<b>Duration:</b>	Instant
<b>Skill Type:</b>	Miscellaneous		
<b>Prerequisites:</b>	None		
<b>Skill List:</b>	Master Miscellaneous		

This skill allows the character to interrogate another character and force one truthful answer from them. It takes 5 minutes to use this skill and during that time the character should roleplay his interrogation of the target character. For every purchase of the Stamina skill the target character has, they can prolong the time it takes to use this skill by 10 minutes. So a character with three purchases of the Stamina skill could hold out for 30 minutes. This skill can be countered by the Courage skill. No other skill or spell will stop this skill.

Paladins and Dark Paladins are immune to the Interrogate skill.

**Iron Will**

<b>Build Cost:</b>	10	<b>Purchase:</b>	Multi
<b>Tagged:</b>	Yes	<b>Duration:</b>	Instant
<b>Skill Type:</b>	Miscellaneous		
<b>Prerequisites:</b>	None		
<b>Skill List:</b>	Master Miscellaneous		

This skill trains the character's mind to resist charms. The character can use this skill to stop: any Charm School spell, any racial charms like Satyr/Faun charm, the Hypnosis skill, charm like effect Spell Songs, charm like effect Nature Magic, Ritual of Domination, Possession, Vampiric charm, Draconic or Hierarch charm, or any other charm affect. This skill will not stop a fear effect.

This skill has no obvious effects when used and does not need to be called out loud. This skill must be used immediately after the attack. A player could not wait until they are given a command they do not like then use this skill to free their mind to disobey the order. The one exception to this rule is charm effects that have a base duration of longer than 1 hour. The character may use his Iron Will to regain self control for 10 minutes. Some examples are: being an undead under the control of another, being under the effects of a Ritual of Domination, or a Demonic Charm. A spell that has been augmented with the Spell Binding skill does not fall under this exception as the base duration is still 1 hour or less.

This skill can never be used to stop any Follower of the Light or Servant of Darkness turn or control skill.

**J****Jump**

<b>Build Cost:</b>	3	<b>Purchase:</b>	Once
<b>Tagged:</b>	No	<b>Duration:</b>	<i>Special</i>
<b>Skill Type:</b>	Dexterity		
<b>Prerequisites:</b>	None		
<b>Skill List:</b>	Master Miscellaneous		

This skill has only one use, to overcome obstacles encountered during game play which do not physically exist. It cannot be used to jump over a stone wall if the stone wall is there out-of-game, but if the Marshal only describes the wall or if the wall is only represented by a tarp, string or other out-of-game item, then the character can use this skill. The Marshal will have final say as to whether the character successfully uses this skill. This skill cannot be used to prevent falling damage of any kind. The character is able to jump 10 feet straight up, 20 feet out, or 30 feet down.

This skill cannot ever be used in a combat situation, in other words the character cannot use this skill to jump into a fight, out of a fight, as a means to escape pursuit, or to leap to an unreachable location and attack. It can never be used as a means to jump from tree to tree as a mode of travel, regardless of the character. This skill can only be used to overcome non-existent obstacles.

**K****Killing Blow Magic**

<b>Build Cost:</b>	2	<b>Purchase:</b>	Once
<b>Tagged:</b>	No	<b>Duration:</b>	Constant
<b>Skill Type:</b>	Arcane		
<b>Prerequisites:</b>	Mage Basic Career Skill List, Rank 4 of Any School of Magic		
<b>Skill List:</b>	Warlock		

This skill allows the character to augment a Killing Blow done with their bare hands. Normally, a bare hand can only do 1 point of damage for Killing Blows only; a character with this skill can do 10 points of magical damage with their bare handed Killing Blows.

The character must say: "*One Killing Blow, Two Killing Blow, Three Killing Blow, Ten Magic*". You may do less than 10 points of damage, but it is always magical damage. This skill can be blocked with the use of a defense that stops magical attacks. It can be performed any number of times after it is purchased.

Use of this skill does not require a focus. No other Warlock skills can be used with this skill.

**L****Literacy**

<b>Build Cost:</b>	4	<b>Purchase:</b>	Multi
<b>Tagged:</b>	No	<b>Duration:</b>	Constant
<b>Skill Type:</b>	Miscellaneous		
<b>Prerequisites:</b>	None		
<b>Skill List:</b>	Miscellaneous Skill List		

This skill allows the character to read and write one specific language per purchase of this skill. A separate Literacy skill is needed for each language the character wishes to know. This skill does not give the character the ability to speak the language. Most of the languages a character can learn are given below.

Language
Common
Elven
Dark Elven
Dwarven
Kalitanian
Nymidian
Carthidian
Draconic
Hierarch

A character can only start with the Literacy skills for their race.



**Lie**

<b>Build Cost:</b>	3	<b>Purchase:</b>	Multi
<b>Tagged:</b>	Yes	<b>Duration:</b>	Instant
<b>Skill Type:</b>	Faith		
<b>Prerequisites:</b>	Dark Cleric		
<b>Skill List:</b>	Servant of Darkness		

With the purchase of this skill, the character is able to lie while under the effects of a charm spell or truth inducer once, per tag, per question asked per truth inducer or charm. Therefore if the character is subjected to a *Speak the Truth* spell, they can use one use of this skill to lie to this question. If asked the same question with another *Speak the Truth* spell, the character needs to use another use of this skill. However, if the character is dominated or enslaved by spell or skill, then no matter how many times they are asked the same question, they may use one Lie tag to stop all those questions.

This skill will also prevent you from being forced to commit an action that would answer a question. For example, if a character was dominated and asked if they were an assassin, they could use this skill to lie to that question. For as long as that particular *Domination* spell was in affect they could continue to lie. If they were asked to raise their arm, stand, dance, etc. if they were an assassin they could "lie" and not follow those commands. However, if they were ordered to follow the caster, protect the caster, or any other similar action they would be compelled to do so. If the character was again dominated and asked the same question, they would have to use another purchase of the Lie skill to lie.

**M****Make Contact**

<b>Build Cost:</b>	3	<b>Purchase:</b>	Once
<b>Tagged:</b>	No	<b>Duration:</b>	Constant
<b>Skill Type:</b>	Arcane		
<b>Prerequisites:</b>	Any One Rank 3 of Potions, Poisons, or Solutions		
<b>Skill List:</b>	Alchemist, Assassin		

This skill will make an alchemical item into contact item. Contact items can be administered by touch, by applying it to an item, applying it to an edged weapon, or thrown. If placed on an item, the character must make skin contact to take effect. When used on a weapon the player must call *poison* after the damage of the blow, and if Body Points are hit, the item takes effect. When thrown it must hit the player and the character must have 0 Armor Points currently for it take effect.

This skill cannot be used on alchemical items that have already been created. Using this skill increases the number of Production Points and Reagent Tags needed. The table below outlines these requirements.

Make Contact Table			
	Production Point Increase	Reagent Tag Increase	Additional Component
Contact	+50%	+50%	Pitchblende

Whether this skill works on an alchemical item is noted in the item's description.

**Make Gaseous**

<b>Build Cost:</b>	3	<b>Purchase:</b>	Once
<b>Tagged:</b>	No	<b>Duration:</b>	Constant
<b>Skill Type:</b>	Arcane		
<b>Prerequisites:</b>	Any Two Rank 4 of Potions, Poisons, or Solutions		
<b>Skill List:</b>	Alchemist		

This skill allows the alchemist to make some alchemical items gaseous. All gaseous items have a radius indoors and outdoors and effects every one in the radius, including the character who delivered it if they are in the area of effect. To determine who is effected, the character struck with the gas or the closest player to the gas should stretch their arms out to either side and turn in a circle and anyone in that radius that the player can touch is affected.

This skill cannot be used on alchemical items that have already been created. Using this skill increases the number of Production Points and Reagent Tags needed. The table below outlines these requirements.

Make Gaseous Table			
	Production Point Increase	Reagent Tag Increase	Additional Component
Gaseous	+100%	+100%	1 pt. of Acid

Whether this skill works on an alchemical item is noted in the item's description.

**Master Assassin**

<b>Build Cost:</b>	8	<b>Purchase:</b>	Once
<b>Tagged:</b>	No	<b>Duration:</b>	Constant
<b>Skill Type:</b>	Dexterity		
<b>Prerequisites:</b>	Rogue Basic Career Skill List, 20 Build Points of Dexterity Skills		
<b>Skill List:</b>	Assassin		

When a character purchases this skill they gain the ability to use: Small Weapon, Thrown Weapon, One-Handed Edge, Bow, Crossbow, and the Florentine skill. The character also gains the ability to use two One-Handed Edge weapons Florentine style.

Additionally, any Build Points the character may have spent on these weapon skills are refunded when this skill is learned. So, if a character has One-Handed Edge skill, Florentine skill and Thrown Weapon skill the character would get back a total of 8 Build Points, effectively getting the Master Assassin skill for free.

**Master Florentine**

<b>Build Cost:</b>	4	<b>Purchase:</b>	Once
<b>Tagged:</b>	No	<b>Duration:</b>	Constant
<b>Skill Type:</b>	Martial		
<b>Prerequisites:</b>	Warrior Basic Career Skill List, Florentine, 1 Master Proficiency		
<b>Skill List:</b>	Master Warrior		

A character with this skill may use any weapon of any length in either hand that the character has the skill to use. Two-handed weapons may be used only to block, and bastard weapons may be used to deal one-handed damage. This skill will allow the character to use two one-handed weapons at the same time.

**Master Parry**

<b>Build Cost:</b>	4	<b>Purchase:</b>	Multi, <i>Special</i>
<b>Tagged:</b>	Yes	<b>Duration:</b>	Instant
<b>Skill Type:</b>	Martial		
<b>Prerequisites:</b>	Warrior Basic Career Skill List, 2 Proficiencies		
<b>Skill List:</b>	Master Warrior		

This skill may be used to parry any physical blow including special attacks such as Critical Attack, Stunning Blow, Disarm, or a blow that does damage, but not the Slay skill. This skill can be used even if it is delivered from behind, but not if from a surprise attack; therefore it is impossible to parry an Assassinate skill. It is also possible to parry an attack directed against someone else as long as they are within weapons length. A character cannot use a ranged attack to parry an attack for another. The character may block any low magic or Nature Magic spell that is not combined with a Perfect Aim skill for another character, but they then take the effect of the spell and must call an appropriate defense that will stop the spell in order to avoid the effects of the spell themselves.

*For example, Drokk is fighting three brigands. One of them runs away into the woods. The fight with the last two continues for a while. The two brigands move around so they are on opposite sides of Drokk, then one of them, from behind, uses the Speed and Stun skills against Drokk. Drokk might not have seen the blow coming, but he knew his opponent was there and uses his Master Parry skill to stop the attack. Distracted, Drokk does not see the third brigand sneaking back up to him. This one sees his chance and uses a Shatter Weapon skill against Drokk from behind and surprise. Drokk cannot use his Master Parry skill to stop this attack and calls his Invulnerability spell to stop the attack. Now Drokk is really mad and the brigands are in for a tough time.*

A character must have one Proficiency skill per Master Parry skill they wish to purchase. So, a character that wants three Master Parry skills must have three Proficiency skills. The Master Parry skill can be used with any weapon the character has two Proficiency skills of either type. Therefore, if the character has two Master Proficiency skills they can use their Master Parry with any weapon.

The character must call “Master Parry” when they use this skill. This skill is always used once called.

**Master Proficiency**

<b>Build Cost:</b>	13	<b>Purchase:</b>	Multi
<b>Tagged:</b>	No	<b>Duration:</b>	Constant
<b>Skill Type:</b>	Martial		
<b>Prerequisites:</b>	Warrior Basic Career Skill List, 2 Non-Master Proficiencies		
<b>Skill List:</b>	Master Warrior		

For each purchase of this skill, a character gains a Damage Bonus with all weapons in which they have a weapon skill and according to the table below.

Weapon Type	Damage Bonus
Small, Thrown, One-Handed, Bastard, Staffs, and Crossbows	+1
Two-Handed, Polearm, Bows	+1.5 <sup>‡</sup>

This may be combined with any other Damage Bonus the character has. Master Proficiency is not hand specific and therefore will add to both weapons of a character using the Florentine skill, but only adds once for two-handed or bastard weapons.

**Master Set Traps**

<b>Build Cost:</b>	5	<b>Purchase:</b>	Once
<b>Tagged:</b>	No	<b>Duration:</b>	Constant
<b>Skill Type:</b>	Dexterity		
<b>Prerequisites:</b>	Quick Disarm, Set Trap 4		
<b>Skill List:</b>	Master Thief		

This skill allows the character to set traps with no minimum time requirement other than the time it actually takes the player to set the trap. Additionally, it gives the character an extra free rank of Set Traps. So, if the character has Set Traps 4, then can set traps as if they had Set Traps 5.

**Master Waylay**

<b>Build Cost:</b>	5	<b>Purchase:</b>	Once
<b>Tagged:</b>	No	<b>Duration:</b>	5 Minutes
<b>Skill Type:</b>	Dexterity		
<b>Prerequisites:</b>	Waylay and 20 Build Points of Additional Dexterity Skills		
<b>Skill List:</b>	Master Thief		

This skill works the same way as the Waylay skill with three exceptions. First, Master Waylay is delivered subtly so the character only needs to call the attack loud enough for the target to hear it. The character being attacked may be in combat but the character using this skill cannot be in combat. Finally, the character should prefix their damage with “Master Waylay.”

**Medium**

<b>Build Cost:</b>	3	<b>Purchase:</b>	Once
<b>Tagged:</b>	No	<b>Duration:</b>	Constant
<b>Skill Type:</b>	Arcane		
<b>Prerequisites:</b>	None		
<b>Skill List:</b>	Miscellaneous Skill List		

This skill allows the character to perform a séance which takes 10 minutes of roleplay and requires the normal trappings of a séance – such as candles, incense, holding hands, etc. – and thereby speak to spirits. The spirits must be willing, though the character can request a spirit’s presence. It is up to the discretion of a Plot Marshal as to whether the spirit appears or not and whether the skill works. A spirit can make its presence known to the medium and it is up to the medium whether or not they wish to perform the séance.

This skill does not allow the character to see spirits and the character cannot be sure by simply the sound of the voice if they have contacted the correct spirit.

This skill will only let the character speak to a spirit that has been dead for more than 10 years.

<sup>‡</sup> Note: The bonus is rounded down so one purchase give a +1 Damage Bonus and two purchases give a +3 Damage Bonus.

**Missile Deflection**

<b>Build Cost:</b>	3	<b>Purchase:</b>	Multi
<b>Tagged:</b>	Yes	<b>Duration:</b>	Instant
<b>Skill Type:</b>	Dexterity		
<b>Prerequisites:</b>	Rogue Basic Career Skill List		
<b>Skill List:</b>	Assassin, Master Thief		

This parry skill allows the character to deflect any ranged attack including ones that use the True Aim skill or use any special martial skill, except the Slay skill. The character should call "Missile Deflect" to use this skill. This skill can be used even if it is delivered from behind, but not if from a surprise attack; therefore it is impossible to parry the Assassinate skill. It is also possible to parry an attack directed against someone else as long as they are within weapons length. A character cannot use a ranged attack to parry an attack for another. The character may block any low magic or Nature Magic spell that is not combined with a Perfect Aim skill for another character, but they then take the effect of the spell and must call an appropriate defense that will stop the spell in order to avoid the effects of the spell themselves.

This skill is always used once called.

**N****Natural Claws**

<b>Build Cost:</b>	0	<b>Purchase:</b>	Once
<b>Tagged:</b>	No	<b>Duration:</b>	Constant
<b>Skill Type:</b>	Racial		
<b>Prerequisites:</b>	<i>Special</i>		
<b>Skill List:</b>	None		

This skill allows the character to extend and retract sharp claws. The character must use approved LAIRE claws in combat dealing 1 point of damage with each blow. The claws are part of the character's body and may not be coated with poison and doing so would poison the character. Even if the character were immune to the poison, the poison would be expended when applied. The character's claws take damage and any damage dealt to the claws is taken from the character's Body Points.

Damage Bonuses and special weapon attacks, like the Slay, Stun, Waylay, Assassinate, etc. skills, with the exception of the Speed skill and *Inspire* and *Heroism* spell songs, may not be used with the Natural Claws skill. However, the character's Strength Bonus does add to the damage.

The prerequisite for this skill is being a member of a race that has claws. It is normally not available to characters outside these races.

**Nature's Child**

<b>Build Cost:</b>	5	<b>Purchase:</b>	Multi
<b>Tagged:</b>	Yes	<b>Duration:</b>	10 Minutes
<b>Skill Type:</b>	Faith		
<b>Prerequisites:</b>	Pass Without a Trace		
<b>Skill List:</b>	Druid		

When this skill is used the character becomes one with the land, rendering the character inoffensive to plants and animals for 10 minutes. Plants and animals may not attack the character but may attack anyone that may be with them. If the character willingly attacks any plants or animals while this skill is active, the creatures will fight back. A character that does so, loses access to all Followers of the Mother spells and abilities until the end of the **next** Tag Cycle, and must contact a Plot Marshal.

This skill requires the use of the character's focus and a verbal, which must be at least 5 syllables, not including the skill's name, and must contain some reasonably recognizable version of the name of the skill.

**Nature's Health**

<b>Build Cost:</b>	4	<b>Purchase:</b>	Once
<b>Tagged:</b>	No	<b>Duration:</b>	Constant
<b>Skill Type:</b>	Faith		
<b>Prerequisites:</b>	Elemental Pool		
<b>Skill List:</b>	Druid		

This skill makes the character completely immune to all diseases, natural or magical. If the character loses their focus, they lose the protection of this skill.

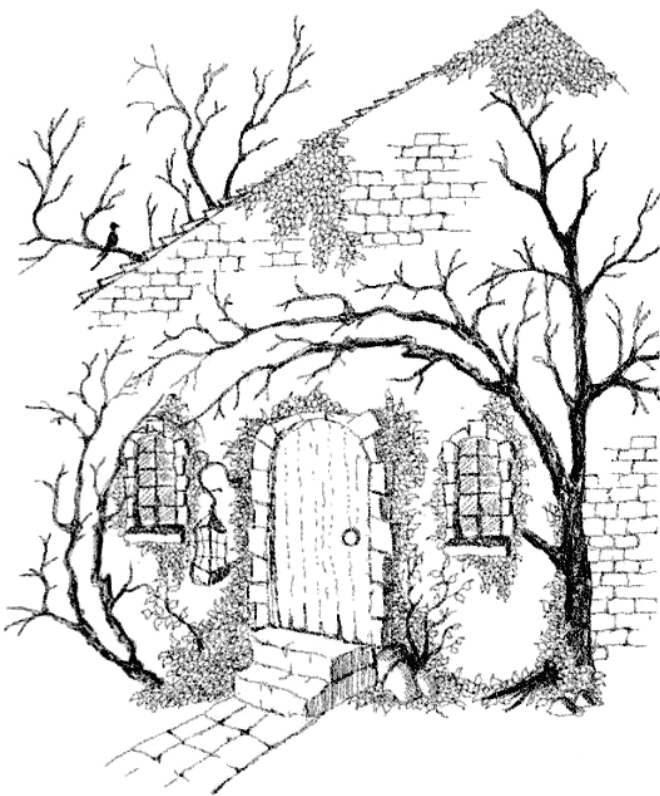

**Nature's Purity**

<b>Build Cost:</b>	5	<b>Purchase:</b>	Multi
<b>Tagged:</b>	Yes	<b>Duration:</b>	10 Minutes
<b>Skill Type:</b>	Faith		
<b>Prerequisites:</b>	Elemental Pool		
<b>Skill List:</b>	Druid		

This skill makes the character completely immune to all poisons, natural or magical, when invoked. The skill can be called as a defense to an attack, however the character must be conscious in order to use the skill.

This skill requires the use of the character's focus.

**Overlay**

<b>Build Cost:</b>	6	<b>Purchase:</b>	Multi
<b>Tagged:</b>	Yes	<b>Duration:</b>	Instant
<b>Skill Type:</b>	Arcane		
<b>Prerequisites:</b>	Any 3 Warlock Skills, <i>Special</i>		
<b>Skill List:</b>	Warlock		

With this skill the character can cast a latent spell on the target character contrary to the normal spell stacking restrictions. In order to use the Overlay skill, the overlaid spell must be cast after the regular spell. When invoking latent spells, the overlaid spell or spells must be invoked in the exact reverse order they were placed upon the character or all spells above the one invoked are lost. Latent overlaid spells are invoked normally and are preceded by the word "Overlay". There is no restriction to the number of stacked spells. This skill can only be used with a spell cast by the character and not when invoked from an item or read from a scroll.

*For example, Herrin has an Absorption spell, Overlay Negation spell, and Overlay Absorption spell cast on him in that order, the first one he would call is "Overlay Absorption", then the "Overlay Negation", then "Absorption". If Herrin called the Overlay Negation spell first, the Overlay Absorption spell would be lost, but the regular Absorption spell remains.*

A Destroy Magic spell will remove all overlaid latent spells, including ones augmented by any other Warlockery, such as the Total Power skill.

The use of this skill is indicated by prefixing the spell verbal by "Upon Your Mystical Defenses..."

**Pain Touch**

<b>Build Cost:</b>	6	<b>Purchase:</b>	Multi
<b>Tagged:</b>	Yes	<b>Duration:</b>	5 Minutes
<b>Skill Type:</b>	Faith		
<b>Prerequisites:</b>	Dark Paladin, 2 Wounding		
<b>Skill List:</b>	Servant of Darkness		

This skill will cause the targeted character to fall to the ground or to their knee in extreme pain. The target character cannot move or take

any other action except invoke latent spells. This affect can be cured by using the Heal Wounds skill to *Heal Body*.

This skill requires the use of the character's focus and a verbal, which must be at least 5 syllables, not including the skill's name, and must contain some reasonably recognizable version of the name of the skill. This skill can be delivered by touch or through a weapon. This skill can be blocked by, and is expended by, a magical defense that stops physical attacks or the Resist Evil skill, or a defensive martial skill which is used but does not expend the Pain Touch skill for that Tag Cycle. This effect can only be cured by a Heal Body cast from a Heal Wounds skill, not the spell.

**Paladin**

<b>Build Cost:</b>	2	<b>Purchase:</b>	Once
<b>Tagged:</b>	No	<b>Duration:</b>	Constant
<b>Skill Type:</b>	Faith		
<b>Prerequisites:</b>	Plot Approval, Cleric		
<b>Skill List:</b>	Follower of the Light		

This skill makes the character permanently immune to all fear effects.

This skill can be purchased in the same month as the Cleric skill.

**Paralyze Touch**

<b>Build Cost:</b>	5	<b>Purchase:</b>	Multi
<b>Tagged:</b>	Yes	<b>Duration:</b>	10 Minutes
<b>Skill Type:</b>	Dexterity		
<b>Prerequisites:</b>	Master Assassin Skill		
<b>Skill List:</b>	Assassin		

This skill allows the character to paralyze the target character with a touch. The character may touch their target anywhere on their body with a spell packet held in their hand. This skill is a non-combat skill and cannot be used on someone engaged in fighting. The Paralysis Touch skill can be countered by the appropriate defense for a physical attack; namely *Invulnerability* spell, a parry skill, Dodge, etc., however, if the target character is surprised, they may not use their martial parry skills.

The target of this skill is rendered paralyzed for 10 minutes. The paralysis can be released by the original character or another character with their use of the Paralysis Touch skill. A *Heal Body* spell will release a paralyzed character.

This skill is not used if the character misses their target or the attack is blocked. If they succeed in touching their target or if the target calls an appropriate defense, the skill is used.

**Pass Without a Trace**

<b>Build Cost:</b>	5	<b>Purchase:</b>	Once
<b>Tagged:</b>	No	<b>Duration:</b>	Constant
<b>Skill Type:</b>	Faith		
<b>Prerequisites:</b>	Druid		
<b>Skill List:</b>	Druid		

Once learned, this skill makes the character unable to be tracked either by skill, scent or other tracking abilities. The character may opt to leave tracks if they wish, but then any character with the appropriate skill can track them.

This skill will not prevent the character from being scried upon with sorcery.



**Perfect Aim**

<b>Build Cost:</b>	6	<b>Purchase:</b>	Multi
<b>Tagged:</b>	Yes	<b>Duration:</b>	Instant
<b>Skill Type:</b>	Arcane		
<b>Prerequisites:</b>	Any 3 Warlock Skills, <i>Special</i>		
<b>Skill List:</b>	Warlock		

Learning this skill allows a character to cast a spell without throwing a spell packet. The spell starts at the caster's index finger and travels to the target. The hand that points the index finger must either be empty or be holding a spell packet. Perfect aimed spells cannot bend corners or "follow" a character out of sight. A Perfect aimed spell can go over a wall spell, but not if that wall spell fills a doorway or other similar structures. As a general rule, so long as a spell packet could physically move from the caster to the target – however improbable – the target is hit.

The range of a Perfect Aim skill is limited to however far the casting character can throw a spell packet when the targeted character is outdoors. The player need not hit the target but has to throw the packet at least as far as the target. It can go farther, but cannot land short. If the character and the targeted character are indoors, the player does not need to throw a spell packet and the attack is not limited by range. Indoors and outdoors, in this case, refers to real world, out-of-game buildings not in-game caves or buildings.

The target can invoke a defense that stops spells normally, but the player cannot physically dodge the spell. All other rules of spell casting apply. The target must be in line of sight at the start and end of the spell verbal – including any Warlock skill verbals.

The Dodge skill can be used to stop a Perfect Aim skill.

*For example, Logan is attacked by a Warlock who begins casting his verbal, "With Perfect Aim, Double Cast, Dragon's Breath Spell." Logan hears the verbal being cast and runs behind the inn out of sight of the caster before she finishes casting. Logan is safe for now and the Warlock has expended the one Speed Cast and 16 Power Points, but not the two Perfect Aims or the Double Cast. Un-daunted, the Warlock picks another target, Dom Dom, who is busy fighting some of the Warlock's undead minions. The Warlock successfully completes the verbal and Dom Dom finds out too late he has been hit by the two spells. He calls two of his Dodge skills stopping each of the spells cast at him. The Warlock is foiled once more.*

This skill can only be used with a spell cast by the character and not when invoked from an item or read from a scroll.

To use this skill, the character must prefix the spell verbal by "*With Perfect Aim...*", and then point their index finger at the target of the spell.

**Pick Lock**

<b>Build Cost:</b>	2/6	<b>Purchase:</b>	Once
<b>Tagged:</b>	No	<b>Duration:</b>	Constant
<b>Skill Type:</b>	Dexterity		
<b>Prerequisites:</b>	None		
<b>Skill List:</b>	Rogue Basic Career Skill List		

This skill allows the character to attempt to pick an in-game lock. Without this skill a character cannot even attempt to pick the lock.

This skill does not guarantee success; the player must pick the lock with what ever tools they have on hand.

**Pick Pockets**

<b>Build Cost:</b>	4	<b>Purchase:</b>	Multi
<b>Tagged:</b>	No	<b>Duration:</b>	Instant
<b>Skill Type:</b>	Dexterity		
<b>Prerequisites:</b>	Speed Search		
<b>Skill List:</b>	Master Thief		

This skill allows a character to pick the pockets of other characters. In order to use this skill the character needs an out-of-game pick pocket tool, which is an alligator clip with a piece of string attached to it. The length of the string starts out at 2 inches and increases by 1 inch for every additional purchase of this skill. The string should be knotted or marked at one inch intervals, and must be approved by a Rogue or Arms Marshal before use. Players may carry any number of clips of the appropriate length.

To use this skill, the character must first get a Rogue Marshal to marshal this skill then the character must place their pick pocket tool anywhere on the targeted character's clothing or person. The clip may not be placed on weapons, shields, or props. Once the clip is placed on the character's person the character walks over to the Marshal, only then are the items stolen. The Marshal will approach the targeted character and remove any single in-game item which the string can reach designated by the character using this skill.

This skill will not allow you to take items which hold other items, such as bags or pouches. Items may be retrieved from within pouches or pockets, from under clothing, or other items of apparel, as long as the string can touch the item while still clipped where the character placed it. The item pilfered can be no larger than the palm of the pickpocket's hand in any direction. If it is larger than the palm the item is not stolen and the attempt fails. No item that is attuned can be stolen and the attempt automatically fails and the target character is alerted to the attempt.

Additional clips may be attached to the target character to steal additional items. Any interruption during the process results in a failed attempt. If the target character catches you placing clips or if you are caught by someone else, you have been caught red-handed and the last attempt fails – nothing is gained from that attempt.

A Marshal must be present to use this skill, no exceptions. If your Marshal is pulled away while marshaling your theft, the attempt fails, but you escape detection for the time-being. The Marshal has final say as to whether something can be pick pocketed.

A character may also use this skill to place items on a character. The character must still place the alligator clip in the area in which they intend to place the item and have the item they wish to place in-hand. When the clip is placed, the character using the skill gives the item to the marshal who then places it within the range of the string. The item to be placed must still be palm sized.

Out-of-game, personal items may be removed only at player's discretion. Items actively held in the hand, being actively used by the target character, or under a glove may not be pick pocketed.

**Poison Immunity**

<b>Build Cost:</b>	5	<b>Purchase:</b>	Multi
<b>Tagged:</b>	No	<b>Duration:</b>	Constant
<b>Skill Type:</b>	Dexterity		
<b>Prerequisites:</b>	Rogue Basic Career Skill List, 20 Build Points of Dexterity Skills ~ or ~ Resist Alchemy		
<b>Skill List:</b>	Assassin, Master Thief, Alchemist		

The character becomes immune to a type of poison and therefore they are immune to all forms of that poison. For example, if they become immune to death poison, then they are immune to Instant Death, Slow Death and Quick Death. Similarly, if the character is immune to damaging poisons then they are immune to all damaging poisons – 8, 12, 16, and 24 point versions. The following table outlines what categories the character can choose from.

Category
Amnesia Poison
Blindness Poison
Damaging Poisons
Death Poisons
Feeblemind Poison
Forget and Remember Poison
Love Poison
Paralysis Poison
Paranoia Poison
Silence Poison
Sleep Poison
Weakness Poison

The character may not become immune to solutions or potions.

**Poison Lore**

<b>Build Cost:</b>	2/6	<b>Purchase:</b>	Once
<b>Tagged:</b>	No	<b>Duration:</b>	Constant
<b>Skill Type:</b>	Dexterity		
<b>Prerequisites:</b>	Herbal Lore, Literacy		
<b>Skill List:</b>	Rogue Basic Career Skill List		

This skill allows the character to recognize alchemical reagents. This is the basic skill for learning the Poison School only and grants the character the knowledge of how to brew, distill, mix, and perform the other basic skills needed to create poisons. It does **not** grant the character the ability to actually make anything; a separate skill is required for that. This skill is required to read and identify poison recipes in-game.

**Poisons School**

<b>Build Cost:</b>	2/2/3/4/5	<b>Purchase:</b>	Multi
<b>Tagged:</b>	No	<b>Duration:</b>	Constant
<b>Skill Type:</b>	Arcane		
<b>Prerequisites:</b>	Alchemy Lore or Poison Lore for Rank 1, Prior Rank for Rest		
<b>Skill List:</b>	Rogue Basic Career Skill List, Alchemist, Assassin		

This skill is purchased in ranks similar to schools of magic. Rank 1 Poisons allows the character to identify all Poisons, which takes the character 1 minute of roleplaying in-game to perform. This can be used to detect and identify poisons in food, drink, or a person's blood. The higher ranks allow the character to brew Poisons of that rank and lower. So a character with Rank 3 Poisons could identify

any Poison and brew any Poison in Rank 2 and Rank 3, as long as they have the recipe.

**Potions School**

<b>Build Cost:</b>	2/2/3/4/5	<b>Purchase:</b>	Multi
<b>Tagged:</b>	No	<b>Duration:</b>	Constant
<b>Skill Type:</b>	Arcane		
<b>Prerequisites:</b>	Alchemy Lore for Rank 1, Prior Rank for Rest		
<b>Skill List:</b>	Alchemist		

This skill is purchased in ranks similar to schools of magic. Rank 1 Potions allows the character to identify all Potions, which takes the character 1 minute of roleplaying in-game to perform. The higher ranks allow the character to brew Potions of that rank and lower. So a character with Rank 3 Potions could identify any potion and brew any Potion in Rank 2 and Rank 3, as long as they have the recipe.

**Poison Spit**

<b>Build Cost:</b>	3	<b>Purchase:</b>	Multi
<b>Tagged:</b>	Yes	<b>Duration:</b>	10 Minutes
<b>Skill Type:</b>	Racial		
<b>Prerequisites:</b>	None		
<b>Skill List:</b>	None		

This skill allows the character to spit a dose of contact Paralysis poison at a target character. This effect is exactly the same as the poison of the same name.

The poison from this skill cannot be collected, stored or dissected by anyone in any way. It cannot be placed on a weapon, and can only be thrown.

The character must call "Poison Spit" when they use this skill.

**Professional Skills**

<b>Build Cost:</b>	1	<b>Purchase:</b>	Once
<b>Tagged:</b>	No	<b>Duration:</b>	Constant
<b>Skill Type:</b>	Miscellaneous		
<b>Prerequisites:</b>	None		
<b>Skill List:</b>	Miscellaneous Skill List		

A professional skill is way for a player to round out their character's background or personality. Professional skills never have any impact on game play other than the rare, incidental situations where, at the marshal's sole discretion and under no obligation, the character may gain some roleplay insight or otherwise unavailable information. For example, a player who has the Professional Skill: Sailor may find themselves in a situation where they must steer a boat, or raise or drop an anchor. The marshal may let the player do this if it fits within the story or module.

**The character does not ever gain any kind of income, item, exclusion, information or preference by having a Professional Skill.** Using the above example, the character who chooses to learn Professional Skill: Sailor does not get a boat, trade routes, connections, contracts, cargo, insight into the economic machinations of the Nobles or a land, receipt of cargo, exemption of their monthly maintenance fee, a place to sleep out-of-game (i.e. on the boat they do not have), etc. Any of these benefits must be earned in-game if ever possible and do not ever come from this skill.

A character may only have one Professional Skill for every 10 Levels, excluding their starting Professional Skill, rounded down. So a Level 14 character may only have an additional Professional Skill; once they turn Level 20 they may learn another if they wish. Characters whose race is Common Man start the game with two

Professional Skills, instead of one. They are still bound by the limit on the number of additional Professional Skills they may purchase. For example, a Level 20 Common Man could have four Professional Skills.

The list of approved and accepted Professional Skills is given in the following table.

Professional Skill Name	
Animal Trainer	Innkeep
Artist	Laborer
Baker	Lumberjack
Bartender	Mason
Blacksmith	Merchant
Candle Maker	Miller
Carpenter	Miner
Carpet Maker	Pig Farmer
Cartwright	Rancher
Clothier	Sailor
Cobbler	Scribe
Cooper	Servant
Crop Farmer	Shipwright
Dairy Farmer	Shop Keep
Fisherman	Soldier
Furrier	Tanner
Gaoler	Teamster
Glass Blower	Thatcher
Guardsmen	Tinker
Herder	Town Crier
Hunter	Trapper

**Q**

**Quick Disarm Trap**

**Build Cost:** 5                      **Purchase:** Multi  
**Tagged:** Yes                      **Duration:** Instant  
**Skill Type:** Dexterity  
**Prerequisites:** Rogue Basic Career Skill List, Disarm Trap, Trap Dodge  
**Skill List:** Master Thief

This skill allows the character to disarm any one non-magical trap, seen or unseen, whether the character is aware of it or not. This skill cannot be used as a defense. The player must declare they are using this skill on something they suspect might be trapped. Then the door, box or item is opened and if there is indeed a trap it is automatically disarmed. If there is no trap then the skill is not used. The character must spend 10 seconds working on the suspected trigger to disarm it.

**Quick Pick Locks**

**Build Cost:** 5                      **Purchase:** Multi  
**Tagged:** Yes                      **Duration:** Instant  
**Skill Type:** Dexterity  
**Prerequisites:** Rogue Basic Career Skill List, Pick Locks, Trap Dodge  
**Skill List:** Master Thief

The character with this skill is able to pick any one non-magical lock the character can see and reach. The player must declare they are using this skill on something they suspect might be locked. Then the door, box or item is opened and if it is indeed locked, it is

automatically unlocked. If the lock is not locked, then the skill is not used. The character must have in-game lock picks to use this skill. The character must spend 10 seconds working on the suspected object to unlock it.

**Quick Study**

**Build Cost:** 3                      **Purchase:** Once  
**Tagged:** No                      **Duration:** Constant  
**Skill Type:** Miscellaneous  
**Prerequisites:** None  
**Skill List:** Miscellaneous Skill List

The character with this skill is a fast learner and can learn a new skill at half the normal in-game time. Normally it takes 5 minutes per Build Point of in-game roleplay to learn a new skill. A quick study will learn a new skill in 2 and a half minutes per Build Point.

To learn an Assassin Proficiency skill normally takes 50 minutes, a character with this skill would learn it in 25 minutes.

This skill is cumulative with the Instructor skill and, so, if the teacher has the Instructor skill, it would only take 12½ minutes to teach an Assassin Proficiency skill.

This skill is not list or skill specific and any skill the character learns can be trained quickly.

**R**

**Rage**

**Build Cost:** 3                      **Purchase:** Multi  
**Tagged:** Yes                      **Duration:** 5 Minutes  
**Skill Type:** Racial  
**Prerequisites:** None  
**Skill List:** None

This skill causes the character to enter into battle frenzy. The character will gain the following benefits while raging:

- Double their Body Point stat
- +2 Strength Bonus
- Immune to Waylay
- Immune to Torso Stun

There are some disadvantages to raging; they are as follows:

- The character cannot cast any magic
- The character will attack their enemies first, then non-Highlanders or Celts, and Highlanders or Celts last
- While under the affects of a rage, the character cannot use any skill that requires free will

To invoke this skill, the character should roleplay getting angry then call their clan's name. During the rage, the character should roleplay being angry and out of control and periodically shout out the name of their clan.

The rage will end after the duration or if the character falls unconscious for any reason. Other Highlanders or Celts can end a rage if they roleplay talking the raging character down for 1 minute.

**Read Magic**

<b>Build Cost:</b>	1/6	<b>Purchase:</b>	Once
<b>Tagged:</b>	No	<b>Duration:</b>	Constant
<b>Skill Type:</b>	Arcane		
<b>Prerequisites:</b>	Any Literacy Skill		
<b>Skill List:</b>	Mage Basic Career Skill List		

When the character learns this skill they are able to read magical writing. This skill is needed to use scrolls, without it a character cannot even tell what spell is written on the scroll. This skill is also required to read any tome that teaches you magic, for example the magical tomes in the Guild of Arcane Lore.

**Recover Power**

<b>Build Cost:</b>	2	<b>Purchase:</b>	Multi
<b>Tagged:</b>	Yes	<b>Duration:</b>	Instant
<b>Skill Type:</b>	Arcane		
<b>Prerequisites:</b>	Mage Basic Career Skill List, Rank 4 of Any School of Magic		
<b>Skill List:</b>	Warlock		

This skill allows a character to recover the Power Points and the Spell Holding skill they would have lost if they: error in a spell verbal, miss the target with a spell packet, take damage while casting, or throw a spell packet before the verbal is complete. To use this skill the character must say “*Recover Power*” within 5 seconds after making a mistake. This skill does not work if you hit the target or the target invokes a defense that stops spells to stop the attack.

**Redirect Spell**

<b>Build Cost:</b>	7	<b>Purchase:</b>	Multi, <i>Special</i>
<b>Tagged:</b>	Yes	<b>Duration:</b>	Instant
<b>Skill Type:</b>	Martial		
<b>Prerequisites:</b>	Channeling		
<b>Skill List:</b>	Master Warrior		

This skill allows the character to channel a spell they were hit with through their weapon into any target. Once successfully hit with a spell attack, the player must call “Redirect” and then has 5 seconds to channel the spell away from them into their target upon a successful weapon strike.

The character can redirect a spell augmented by Warlock skills, however the spell loses all of its augmentations and only the base spell is redirected. A character can only redirect a spell if they are wielding a weapon (not just in their hand) at the time. If the character has two weapons, not including a shield, they may redirect two spells.

If no target is available to redirect the spell into, then the character may redirect the spell into the ground or some other inanimate object. If a character does not ground the spell, after 5 seconds the spell will harmlessly go away.

Additionally, the character needs a weapon of quality to redirect spells. Normal weapons and temporarily alloyed weapons will not work. Any attempt to redirect a spell using a normal weapon fails and the spell will affect the character normally.

Only low magic schools can be redirected, therefore, Spell Songs and Nature Magic cannot be redirected.

A character must have 15 Power Points per Redirect Spell skill they want to learn. This includes the 30 Power Points needed to learn the Channeling skill.

This skill is always used once called.

**Repel Undead**

<b>Build Cost:</b>	5	<b>Purchase:</b>	Multi
<b>Tagged:</b>	Yes	<b>Duration:</b>	<i>Special</i>
<b>Skill Type:</b>	Faith		
<b>Prerequisites:</b>	Turn Lesser Undead		
<b>Skill List:</b>	Follower of the Light		

This skill will force all lesser undead and lesser demons, or one specific greater undead or greater demon to stay 10 feet away from the character for as long as they hold up their focus. The undead or demons may not attack, cast spells directed towards the character, or even look at the character. This skill does not require concentration and will remain in effect so long as the character continues to hold up their focus and in the case of a single target, towards the target character. The character may take offensive actions and cast spells while maintaining a repel, but should they take damage, the effect will end. Note that a character may only maintain one Repel Undead at a time and cannot use any of their other turn undead skills while maintaining a Repel Undead skill.

This skill can only be countered by a Servant of Darkness control skill, Empower skill or sorcery; necromancy or abilities will not counter this skill.

This skill requires the use of the character’s focus and a verbal, which must be at least 5 syllables, not including the skill’s name, and must contain some reasonably recognizable version of the name of the skill.

**Researcher**

<b>Build Cost:</b>	3	<b>Purchase:</b>	Once
<b>Tagged:</b>	No	<b>Duration:</b>	Constant
<b>Skill Type:</b>	Arcane		
<b>Prerequisites:</b>	None		
<b>Skill List:</b>	Miscellaneous Skill List		

This skill allows the character a better chance to research a new alchemical item or sorcery ritual. This skill give a +10% bonus to their success role. In addition, this skill will allow a character to research in-game information in a library, such as the Ducal Library, at a reduced in-game price.

**Resist Alchemy**

<b>Build Cost:</b>	3	<b>Purchase:</b>	Multi
<b>Tagged:</b>	Yes	<b>Duration:</b>	Instant
<b>Skill Type:</b>	Arcane		
<b>Prerequisites:</b>	Alchemy Lore, Any Two Rank 3 of Potions, Poisons, or Solutions		
<b>Skill List:</b>	Alchemist		

This skill allow the Alchemist to resist the effects of any alchemical item or effect the alchemist is exposed to, except acids, *Fire Breath* potion, or any other item that causes external direct damage or effect.

**Resist Evil**

<b>Build Cost:</b>	5	<b>Purchase:</b>	Multi
<b>Tagged:</b>	Yes	<b>Duration:</b>	Instant
<b>Skill Type:</b>	Faith		
<b>Prerequisites:</b>	Paladin		
<b>Skill List:</b>	Follower of the Light		

This skill will stop one of the following skills: Death Touch, Pain Touch, Venom Touch, Sever Soul, or one Wounding strike. Both the Resist Evil and the resisted skill are used. In the case of use against Sever Soul, this skill can be used when the character is not conscious.



**Resist Spell**

<b>Build Cost:</b>	3	<b>Purchase:</b>	Multi
<b>Tagged:</b>	Yes	<b>Duration:</b>	Instant
<b>Skill Type:</b>	Racial		
<b>Prerequisites:</b>	None		
<b>Skill List:</b>	None		

This skill will allow the character to negate the effects of any one low magic spell, Spell Song, Sorcery ritual, or Warlock augmented spell. This skill will not stop Nature Magic spells.

This skill is not latent and the character has to call this skill when they are affected by one of the listed effects. If a character has another defense against the spell effect they must call their Resist Spell skill first. If a character is out of Resist Spell skill uses for that Tag Cycle they do not have to call another defense against the affect.

This skill will not work if the character is unconscious.

**Resist Truth**

<b>Build Cost:</b>	3	<b>Purchase:</b>	Multi
<b>Tagged:</b>	Yes	<b>Duration:</b>	<i>Special</i>
<b>Skill Type:</b>	Dexterity		
<b>Prerequisites:</b>	Rogue Basic Career Skill List		
<b>Skill List:</b>	Assassin, Master Thief		

With the purchase of this skill, the character is able to lie while under the effects of a charm spell or truth inducer once, per tag, per question asked per truth inducer or charm. Therefore if the character is subjected to a *Speak the Truth* spell, they can use one use of this skill to lie to this question. If asked the same question with another *Speak the Truth* spell, the character needs to use another use of this skill. However, if the character is dominated or enslaved by spell or skill, then no matter how many times they are asked the same question, they may use one Resist Truth tag to stop all those questions.



This skill will also prevent you from being forced to commit an action that would answer a question. For example, if a character was dominated and asked if they were an assassin, they could use this skill to lie to that question. For as long as that particular *Domination* spell was in affect they could continue to lie. If they where asked to raise their arm, stand, dance, etc. if they were an assassin they could “lie” and not follow those commands. However, if they were ordered to follow the caster, protect the caster, or any other similar action they would be compelled to do so. If the character was again dominated and asked the same question, they would have to use another purchase of the Resist Truth skill to lie.

This skill will not work against the Detect Lie skill.

**Set Trap**

<b>Build Cost:</b>	<i>Special</i>	<b>Purchase:</b>	5 Times
<b>Tagged:</b>	No	<b>Duration:</b>	Constant
<b>Skill Type:</b>	Dexterity		
<b>Prerequisites:</b>	Disarm Trap		
<b>Skill List:</b>	Rogue Basic Career Skill List, Master Thief		

The player with this skill should read the section in Chapter 7 dealing with setting and removing traps and general in-game thievery before they use this skill.

The character with this skill can set traps that vary in effect and damage based on how many ranks of the Set Trap skill they have. There are many different types of approved traps that can be set at LAIRE and the character can set any of them with this skill alone.

For every rank of the Set Trap skill the character has they can make a trap that deals 5 points of normal damage, up to a maximum of 25 points per trap that only effects the character that set off the trap. The trap can be made to affect an area. For every rank used, the radius can be extended by 5 feet, up to a maximum of 10 feet. A rank can only either add to the damage or increase the radius of effect. So, a character with five ranks of the Set Trap skill can make a trap that will affect a single character dealing 25 points of normal damage, a trap that deals 20 points of damage in a 5 foot radius, or 15 points of damage in a 10 foot radius. The character can make traps using less than their maximum number of ranks. In the above case, a character can make a trap that deals 5 points of damage to a single person even though they have five ranks of the Set Trap skill.

The basic trap deals normal physical damage. The type of damage can be changed by expending the additional cost given below. So, a character can make a trap that deals fire damage, silver damage, or Dwarven damage, but not a combination of these effects. With five ranks of the Set Trap skill, the character can incorporate an alchemical item into their traps. The character must choose to deal damage or an alchemical item, not both. If the alchemical item affects a single character then it must be a contact item. The Set Trap skill cannot augment the alchemy in anyway; therefore an alchemical item that is contact cannot be made to affect an area with this skill. The character must acquire the alchemy separately in addition to the appropriate cost for setting a Rank 5 trap.

A Trap Tag must be purchased from the Treasure Marshal or a Rogue Marshal ahead of time. The character declares what the trap’s effect will be when they purchase it and it is recorded on the tag. This cannot be changed later. The character pays the required in-game money and provides any extra cost for making the desired trap at the time the tag is acquired. A character must have the required number

of ranks of the Set Trap skill to set a trap. For example, a character finds a Rank 5 trap but only has two ranks of the Set Trap skill; they cannot use that trap. Setting a trap takes 1 minute per rank of the trap. A trap must be placed on an object and cannot be set on a character. A character cannot set a trap on a Skeleton, a Golem, an Elf or any other character. Each trap must have its own independent trigger and each trigger can only have one trap. You cannot string traps together. You can set a trap to go off on a box when it is opened, and on an object in the box, but could not set two traps to go off when the lid is opened, ever.

There is no targeting of traps and no chance the trap will miss. The player needs to call the appropriate defense that stops physical attacks to avoid damage. A character may not use martial defenses like the Slay Parry, Master Parry or Critical Attack skills.

A trap can only be disarmed with the Disarm Trap skill. A character can teach another how to disarm a specific trap on a particular object. For example, a character can set a trap on a box and teach his friends how to disarm that specific trap. Even if the character comes across another trap of the exact same type, they cannot disarm it. A trap must always be able to be disarmed.

The cost of a trap is given in the table below.

Effect	Cost
Each Rank of the Trap	5 Copper Pieces
Fire Damage	5 Copper Pieces
Copper Damage	1 Copper Piece
Silver Damage	1 Silver Piece
Gold Damage	5 Silver Pieces
Mithril Damage	10 Silver Pieces

So, a rank 3 trap that deals 10 points of silver damage in a 5 foot radius would cost the character 25 copper pieces. A rank 3 trap that deals 5 points of fire damage in a 10 foot radius would cost the character 20 copper pieces.

All traps are purchased whole and cannot be augmented later or disassembled for parts. Once a trap is set, it normally cannot be reused unless it is disarmed without damaging the physical trap itself.

### Sever Limb

<b>Build Cost:</b>	10	<b>Purchase:</b>	Multi
<b>Tagged:</b>	Yes	<b>Duration:</b>	Instant
<b>Skill Type:</b>	Martial		
<b>Prerequisites:</b>	1 Stun, 1 Slay, Continuous +3 Strength Bonus		
<b>Skill List:</b>	None		

This skill works just like the Stun skill, except the limb is removed. The head is not a limb for this skill. The character should suffix their normal damage called with “Sever Limb”. Anything held in the hand or on the arm should be dropped to the ground next to the target character. This skill has no effect if the character is struck in the torso, a limb must be targeted for this skill to work. Removal of the limb does not influence death system status.

This skill requires the character to have a +3 Strength Bonus to learn and use. This can either be a natural racial bonus or from some other source, such as a magic item. However, the bonus must be a continuous bonus, not one that has a duration or is invoked for a duration. Therefore, a *Strength Potion* does not count towards this prerequisite.

### Sever Soul

<b>Build Cost:</b>	4	<b>Purchase:</b>	Multi
<b>Tagged:</b>	Yes	<b>Duration:</b>	Instant
<b>Skill Type:</b>	Faith		
<b>Prerequisites:</b>	Death Touch		
<b>Skill List:</b>	Servant of Darkness		

This skill can only be used on a character that has been brought to the Brink of Death and will bring them to the end of their Death Count. This skill takes 60 seconds to use. The character should deliver this skill, by touch or through a weapon, like a Killing Blow, “<verbal> Sever Soul 1, Sever Soul 2, Sever Soul 3...” up to a 60 second count. The character only needs to say “Sever Soul” every 5 seconds after the first three and before the last three. This count must be said in an audible voice and is obvious to others looking out. Though the target character is not forced to leave the body, they may at any time after this skill is used. This skill can be blocked by the Resist Evil skill.

This skill requires the use of the character’s focus and a verbal, which can be of any length and must contain the name of the skill.

### Shapeshift

<b>Build Cost:</b>	7	<b>Purchase:</b>	Multi
<b>Tagged:</b>	Yes	<b>Duration:</b>	1 Hour
<b>Skill Type:</b>	Faith		
<b>Prerequisites:</b>	Claws, Nature’s Child		
<b>Skill List:</b>	Druid		

When this skill is purchased, the character gains the ability to transform into a normal animal with stats from the normal form of the animal from the Codex of Monstrous Creatures each time the skill is used. All armor and items worn – magical or otherwise – change into the new form and any access to them is lost, however, the benefits of any magic item is still available to the character except magic items that need to leave the character to be useful.

When a character transforms, they must drop to their hands and knees for 1 minute to role-play the shift. During this time, the character puts on the appropriate costuming for the animal. The character can be attacked and harmed during this time and no skills or abilities can be used. The Druid may call latent spell defenses or invoke spell defenses from items, however. Taking damage will not interrupt the transformation unless the Druid is rendered unconscious or worse. If the character is interrupted, they do not use the skill for that Tag Cycle.

They also suffer the following detriments while shapeshifted:

- They cannot speak common, but can understand what others are saying
- They lose access to all skills, abilities, racial abilities, Body Points, etc of their old form and completely take on the stats of their new form.
- Cannot perform any physical activity the animal cannot naturally perform, for example, opening doors, writing, riding a horse, cooking dinner, etc.
- Cannot use any weapons or shields

While shape changed, the character appears as a completely normal and natural version of the animal form chosen.

When the character changes back to their natural form and they are down Body Points, they are down the same amount of Body Points in their normal form. If this would normally put them at zero or less Body Points, the character is at 1 Body Point.

The change normally lasts 1 hour, but the character may change back to their natural form at will. If while in the animal form, the character is Mortally Wounded or brought to the Brink of Death, they are forced back into their natural form. The character may expend another purchase of this skill at the end of the duration to continue staying in their shapeshifted form without changing back first.

To use this skill the character must have weapons and costuming appropriate to the animal form. Plot has the final say on the stats of the animal and if it is appropriate.

This skill requires the use of the character's focus and a verbal, which must be at least 5 syllables, not including the skill's name, and must contain some reasonably recognizable version of the name of the skill.

### Shatter Weapon

<b>Build Cost:</b>	5	<b>Purchase:</b>	Multi
<b>Tagged:</b>	Yes	<b>Duration:</b>	Instant
<b>Skill Type:</b>	Martial		
<b>Prerequisites:</b>	Warrior Basic Career Skill List, 1 Proficiency		
<b>Skill List:</b>	Master Warrior		

Using this skill, a character may shatter any weapon or shield, regardless of size, using a one-handed edge or a one-handed blunt weapon or larger. Magic, Mithril and unshatterable weapons may not be broken by use of this skill.

To use this skill, the character must strike their target and hit either their body or weapons. This skill can be used as a defense and cannot be called if another character strikes them or they block with their weapon.

This skill is not used if the character misses their target. If they succeed in striking their target, or if the target calls an appropriate defense, the skill is used.

The character must call "Shatter Weapon/Shield" when they use this skill.

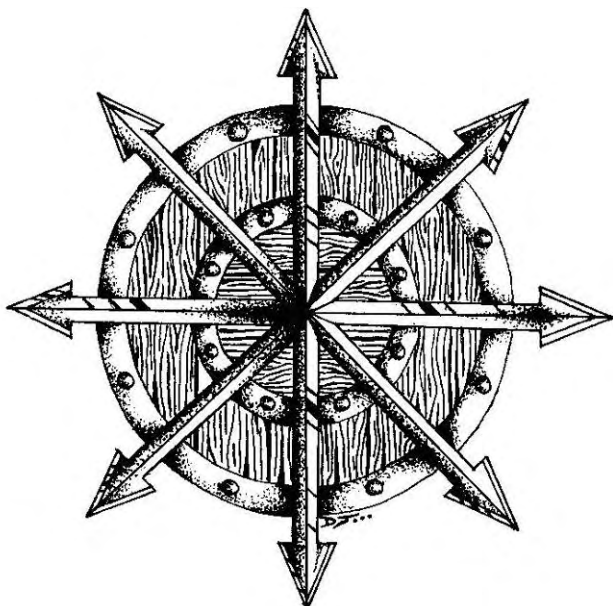

### Shield Parry

<b>Build Cost:</b>	3	<b>Purchase:</b>	Once
<b>Tagged:</b>	No	<b>Duration:</b>	Constant
<b>Skill Type:</b>	Martial		
<b>Prerequisites:</b>	Warrior Basic Career Skill List, 1 Proficiency, Any Shield Skill		
<b>Skill List:</b>	Master Warrior		

This skill allows the character to use any martial parry skill they know with their shield.

### Shield Skill

<b>Build Cost:</b>	<i>Variable</i>	<b>Purchase:</b>	Once
<b>Tagged:</b>	No	<b>Duration:</b>	Constant
<b>Skill Type:</b>	Martial		
<b>Prerequisites:</b>	None		
<b>Skill List:</b>	Warrior Basic Career Skill List		

With this skill, a character becomes able to wield a shield and gives that character ability to block damage with a shield. Without this skill, if a character is holding a shield and the shield is struck, the character takes damage as if they were not holding the shield. A shield must be wielded to be effective; the character must hold it by the handle with a hand and arm that is not impaired. If the character holds it incorrectly or the hand or arm is impaired, then any blows struck on the shield effect the character normally, just as if they did not have the shield.

Shields are not weapons and cannot be used to attack under any circumstances. No martial skill can be used with a shield regardless of the skill. However, if the character purchases the Shield Parry skill, they may then use any of their defensive martial skills with their shield.

A shield worn on the back affords the character no protection. A character cannot block an attack effectively simply by wearing multiple shields, even if they have the appropriate skill.

Shields of quality – Dwarven crafted, mithril, and magic shields – can stop the damaging spells of the elemental schools of magic. The spells that do not cause damage but have an effect such as the *Pin*, *Ice Cast*, *Shatter*, or *Blast* spells cannot be stopped by shields.

### Slay

<b>Build Cost:</b>	10	<b>Purchase:</b>	Multi, <i>Special</i>
<b>Tagged:</b>	Yes	<b>Duration:</b>	Instant
<b>Skill Type:</b>	Martial		
<b>Prerequisites:</b>	Warrior Basic Career Skill List, 2 Proficiencies		
<b>Skill List:</b>	Master Warrior		

This skill allows a character to strike down a target character with one strike. The character hit with this skill is Mortally Wounded and requires the appropriate healing. This skill ignores armor and does not damage it. The character must strike between the elbows to the shoulders and shoulders to the knees of the target character. The character must call "Slay" after the blow is delivered followed by any special damage modifiers, such as "Magic", "Silver", etc. This skill can also be used as a Slay Parry, which will stop any one physical martial attack, even a Slay skill. Either use of this skill expends that use of this skill for that Tag Cycle

A character must have one Proficiency skill per Slay skill they wish to purchase. So, a character that wants three Slay skills must have three Proficiency skills. The Slay skill can be used with any weapon in which the character has two Proficiency skills of either type.



Therefore, if the character has two Master Proficiency skills they can use their Slay with any weapon.

This skill is not used if the character misses their target, does not hit the appropriate area on the target, or the attack is blocked. If they succeed in striking their target or if the target calls an appropriate defense, the skill is used.

### Solutions School

<b>Build Cost:</b>	2/2/3/4/5	<b>Purchase:</b>	Multi
<b>Tagged:</b>	No	<b>Duration:</b>	Constant
<b>Skill Type:</b>	Arcane		
<b>Prerequisites:</b>	Alchemy Lore for Rank 1, Prior Rank for Rest		
<b>Skill List:</b>	Alchemist		

This skill is purchased in ranks similar to schools of magic. Rank 1 Solutions allows the character to identify all Solutions, which takes the character 1 minute of roleplaying in-game to perform. The higher ranks allow the character to brew Solutions of that rank and lower. So a character with Rank 3 Solutions could identify any Solution and brew any Solution in Rank 2 and Rank 3 as long as they have the recipe.

### Sorcery Lore

<b>Build Cost:</b>	2	<b>Purchase:</b>	Once
<b>Tagged:</b>	No	<b>Duration:</b>	Constant
<b>Skill Type:</b>	Arcane		
<b>Prerequisites:</b>	Create Scroll, 4 <sup>th</sup> Rank of Any School		
<b>Skill List:</b>	Sorcerer		

This skill allows the character to read, write, and understand sorcery rituals. The rituals can be in any language, but the terms and concepts are undecipherable to anyone who does not have this skill.

### Speed

<b>Build Cost:</b>	6	<b>Purchase:</b>	Multi
<b>Tagged:</b>	Yes	<b>Duration:</b>	Instant
<b>Skill Type:</b>	Martial		
<b>Prerequisites:</b>	Warrior Basic Career Skill List, 2 Proficiencies		
<b>Skill List:</b>	Master Warrior		

Using this skill, a character may automatically strike their opponent with a single blow. To use this skill the character must strike at the opponent and must prefix the affect with “Speed”, followed by either weapon damage or a specialty attack such as the Disarm or Slay skills. This skill can only be used with hand to hand weapons and not with ranged attacks.

Since Speed is a master level skill, only a Master Parry or a Slay skill will stop this attack. Even if the Speed skill is used with a Disarm, for example, the targeted character must use a master level skill to stop the attack.

This skill is always used once called.

### Speed Cast

<b>Build Cost:</b>	7	<b>Purchase:</b>	Multi
<b>Tagged:</b>	Yes	<b>Duration:</b>	Instant
<b>Skill Type:</b>	Arcane		
<b>Prerequisites:</b>	Any 3 Warlock Skills, <i>Special</i>		
<b>Skill List:</b>	Warlock		

Learning this skill allows a character to cast a spell without saying the complete verbal. When the spell is cast, the Warlock says the name of the spell suffixed by the word “...*Spell*”. The name of the spell does not have to be technically correct: Life spell, Heal Life

spell, Heal this Life spell are all correct. This skill is used when you have said the word “*Spell*”.

This skill can only be used with a spell cast by the character and not when invoked from an item or read from a scroll.

### Speed Search

<b>Build Cost:</b>	6	<b>Purchase:</b>	Once
<b>Tagged:</b>	No	<b>Duration:</b>	Constant
<b>Skill Type:</b>	Dexterity		
<b>Prerequisites:</b>	Rogue Basic Career Skill List, Evaluate Item		
<b>Skill List:</b>	Master Thief		

With this skill, the character is able to completely search an immobile – Unconscious, paralyzed, bound, etc. – character in 10 seconds. One hand must be in contact with the target character while calling “Speed Search 1, Speed Search 2... Speed Search 10”. The 10 seconds should be accompanied by an in-game frisking starting at the head or feet and continuing along the body, as the skill is easily recognizable as a frenzied search. The target must give up any in-game items they have in their possession, except those hidden by magical means or items that are attuned. Items located inside the searched character, swallowed items for example, are revealed as such, but the character must remove the item after the search is completed.

Only one character can search another character at a time. The target character is easily recognizable as having been searched.

### Spell Binding

<b>Build Cost:</b>	4	<b>Purchase:</b>	Multi
<b>Tagged:</b>	Yes	<b>Duration:</b>	6 Hours
<b>Skill Type:</b>	Arcane		
<b>Prerequisites:</b>	Mage Basic Career Skill List, Rank 4 of Any School of Magic		
<b>Skill List:</b>	Warlock		

This skill allows a character to bind a spell to a targeted character thereby extending the duration of a spell to 6 hours. This skill does not work on latent or instant spells. This skill can only be used with a spell cast by the character and not when invoked from an item or read from a scroll.

The use of this skill is indicated by prefixing the spell verbal by “*With Spell Binding...*”

### Spell Holding

<b>Build Cost:</b>	4	<b>Purchase:</b>	Multi
<b>Tagged:</b>	Yes	<b>Duration:</b>	5 Minutes
<b>Skill Type:</b>	Arcane		
<b>Prerequisites:</b>	Mage Basic Career Skill List, Rank 4 of Any School of Magic		
<b>Skill List:</b>	Warlock		

When the character invokes this skill, it will allow them to increase the duration for holding a spell from 5 seconds to 5 minutes. After the spell verbal is completed, the caster must still state the name of the Warlock skills, if any, used and the name of the spell every 5 to 10 seconds. The skill is used once invoked. If the character takes damage or the 5 minutes are up the spell and any Warlock skills that augmented the spell are lost. Note that the normal rules for having a spell in hand are still followed. For more information on this see the chapter on magic.



This skill cannot be used with any type of wall spell. This skill can only be used with a spell cast by the character and not when invoked from an item or read from a scroll.

The verbal for this skill is “*With Spell Holding...*” which must prefix the normal spell verbal.

### Spell Immunity

<b>Build Cost:</b>	5	<b>Purchase:</b>	Multi
<b>Tagged:</b>	No	<b>Duration:</b>	Constant
<b>Skill Type:</b>	Arcane		
<b>Prerequisites:</b>	Mage Basic Career Skill List, Rank 4 of Any School of Magic		
<b>Skill List:</b>	Warlock		

This skill makes a character permanently immune to a specific spell chosen at the time this skill is learned. The character must know how to cast the spell, that is they must have that rank of magic and the spell in that rank. Once learned, the character is no longer able to cast that spell ever again. For example, if a character purchases Spell Immunity to the *Kill* spell then they cannot be affected by a *Kill* spell again under any circumstances. The Character can still cast a spell they are immune to from scrolls or from magic items.

Use of this skill does not require a focus.

### Spell Singer

<b>Build Cost:</b>	3	<b>Purchase:</b>	Once
<b>Tagged:</b>	No	<b>Duration:</b>	Constant
<b>Skill Type:</b>	Arcane		
<b>Prerequisites:</b>	Literacy		
<b>Skill List:</b>	Spell Singer		

This skill makes the character a Spell Singer and gives the character access to Spell Singing magic. In addition, it gives the character 3 Spell Singing Points.

### Stamina

<b>Build Cost:</b>	4	<b>Purchase:</b>	Multi
<b>Tagged:</b>	No	<b>Duration:</b>	Constant
<b>Skill Type:</b>	Martial		
<b>Prerequisites:</b>	None		
<b>Skill List:</b>	Miscellaneous Skill List		

This skill permanently gives the character +3 Body Points each time the skill is purchased. Other than what is listed in this rulebook, this skill will not allow the character to perform any other actions or feats of great stamina.

### Stunning Blow

<b>Build Cost:</b>	6/12	<b>Purchase:</b>	Multi
<b>Tagged:</b>	Yes	<b>Duration:</b>	<i>Special</i>
<b>Skill Type:</b>	Martial		
<b>Prerequisites:</b>	Any 1 Proficiency		
<b>Skill List:</b>	Warrior Basic Career Skill List		

By means of this skill the character is able to deliver a stunning blow to another character. If the target character is struck in the torso then they are affected by a Torso Stun for 5 seconds. If the blow lands on an arm or leg then that limb is broken and must be healed before it can be used again. The character also causes their normal damage when they use this skill. The character should suffix their damage called with the word “Stun”.

*For example, Sir Damien normally causes 18 points of damage with his silver sword. He wants*

*to use his Stunning Blow skill to break an opponent's leg. He swings his sword and calls “18 Silver Stun”, connects with the character's leg and successfully breaks his leg and does 18 points of damage to the opponent. Satisfied with the results, he moves on to the next target.*

A character that is affected by a Torso Stun cannot take any offensive action, any defensive action, call any defenses, invoke any items, cast spells or speak. They may only move slowly and should call out their stun count, “Torso Stun One, Torso Stun Two, etc” for the full 5 seconds. Nothing can heal the character from being Torso Stunned. If a character's arm is broken, they are disarmed as per the Disarm skill and must keep their arm at their side. A character with a broken leg must kneel on that limb and may only crawl. The character cannot jump or hop around on their good leg.

This skill is not used if the character misses their target or the attack is blocked. If they succeed in striking their target or if the target calls an appropriate defense, the skill is used.

Unless the target character is immune to stunning blows or has damage resistance superior to the attack, they take the damage and the effects of the stunning blow.

### Superior Strength

<b>Build Cost:</b>	15	<b>Purchase:</b>	Once
<b>Tagged:</b>	No	<b>Duration:</b>	Constant
<b>Skill Type:</b>	Martial		
<b>Prerequisites:</b>	None		
<b>Skill List:</b>	Miscellaneous Skill List		

This skill grants any character a permanent +1 Strength Bonus, non-combinable. This is combinable with any natural racial Strength Bonus the character already has. This skill can only be purchased and used by a living character. If a living character is turned into an undead, they lose the benefits of this skill.

### Swim

<b>Build Cost:</b>	3	<b>Purchase:</b>	Once
<b>Tagged:</b>	No	<b>Duration:</b>	<i>Special</i>
<b>Skill Type:</b>	Dexterity		
<b>Prerequisites:</b>	None		
<b>Skill List:</b>	Master Miscellaneous		

This skill has only one use, to overcome obstacles encountered during game play which do not physically exist. It cannot be used to swim across an actual lake or river if the water is there out-of-game, but if the Marshal only describes the water obstacle or if the water is only represented by a tarp, string or other out-of-game item, then the character can use this skill. The Marshal will have final say as to whether the character successfully uses this skill. The character walks across the out-of-game representation at a slow walk and can swim any reasonable distance.

## T

### Tight Rope Walker

<b>Build Cost:</b>	4	<b>Purchase:</b>	Once
<b>Tagged:</b>	No	<b>Duration:</b>	Constant
<b>Skill Type:</b>	Dexterity		
<b>Prerequisites:</b>	Rogue Basic Career Skill List, Climb		
<b>Skill List:</b>	Master Thief		

This skill has only one use, to overcome obstacles encountered during game play which do not physically exist. It allows the character to traverse narrow surfaces and rope at a normal pace and fight normally so long as one foot remains on the representation. It cannot be used to walk along the roofs of out-of-game buildings or from tree branch to tree branch, but if the Marshal only describes the ledge or if the rope is only represented by a string along the ground then the character can use this skill. The Marshal will have final say as to whether the character successfully uses this skill.

### Torture

<b>Build Cost:</b>	3	<b>Purchase:</b>	Once
<b>Tagged:</b>	No	<b>Duration:</b>	Constant
<b>Skill Type:</b>	Miscellaneous		
<b>Prerequisites:</b>	None		
<b>Skill List:</b>	Miscellaneous Skill List		

This roleplaying skill allows the character to inflict pain upon a character without doing damage. The target character must be restrained and unable to resist. The character may cause damage if they wish at any point while using this skill; they may even deliver a Killing Blow.

This skill **does not** force a character to answer any question, reveal any information or perform any task. It can be used with the Interrogate skill to force the target character to answer one question truthfully, but the normal rules of the Interrogate skill apply.

This skill **does not** allow a character to mutilate a character without doing damage or magically preserving the character in anyway. For example, a character cannot remove an internal organ or bone without delivering a Killing Blow. They can remove fingers or toenails but not hearts, intestines, or spleens. This skill does not allow the character to alter the target character's physiology in any way, the Evisceration skill is used for that.

### Total Power

<b>Build Cost:</b>	10	<b>Purchase:</b>	Multi
<b>Tagged:</b>	Yes	<b>Duration:</b>	Instant
<b>Skill Type:</b>	Arcane		
<b>Prerequisites:</b>	Any 3 Warlock Skills, <i>Special</i>		
<b>Skill List:</b>	Warlock		

A spell augmented with Total Power penetrates all low magic spell defenses, and affects the target directly. The only low magic spell defense against a spell augmented with Total Power is one that was originally cast with the Total Power skill; if a character has a Total Power *Negation*, they can invoke it against an ordinary *Kill* spell or a Total Power *Kill* spell. The Total Power skill only penetrates spell defenses, not racial abilities or ritual spell defenses. A spell defense augmented by Total Power will still be affected by a *Dispel Magic* spell, or a *Destroy Magic* spell, for example. In regards to *Magic Sanctuary*, *Imprisonment*, and wall spells, Total Power will go through them but in turn cannot be augmented by Total Power to stop

a like augmented spell. A Total Power *Imprisonment* spell will go through a target's spell defenses imprisoning them, but another Total Power spell upon the imprisoned character will still affect them normally – the *Imprisonment* spell is not a “Total Power” *Imprisonment* spell. In the unique case of a character already under the affects of a *Imprisonment* spell, a character casting a Total Power *Imprisonment* spell will go through the imprisonment removing the original and affecting the character with a new *Imprisonment* spell.

This skill can only be used with a spell cast by the character and not when invoked from an item or read from a scroll.

To use this skill, the character prefixes the spell verbal by the phrase “*With Total Power...*”

### Tracking

<b>Build Cost:</b>	6	<b>Purchase:</b>	Once
<b>Tagged:</b>	No	<b>Duration:</b>	Constant
<b>Skill Type:</b>	Miscellaneous		
<b>Prerequisites:</b>	None		
<b>Skill List:</b>	Master Miscellaneous		

In order to successfully use this skill, a Marshal must be present. This skill allows the character to track any character that leaves visible signs of its passing. While using this skill the character must move at a slow walking pace. The Marshal has final say as to the successful use of this skill. If no Marshal is present, this skill fails. In addition, the Marshal must know the whereabouts of the character(s) being tracked. If the Marshal does not know, or cannot discover the whereabouts in a reasonable amount of time, the attempt fails.

*For example, Kenai wants to track a necromancer and his undead that attacked some Avalonians. He gets a Marshal who knows where the NPC's were headed to and marshals the tracking skill. However, when the players arrive at the encounter site, the NPC's are not there. The Marshal has no idea where the NPC's are and therefore the tracking attempt has failed.*

This skill can be used to cover tracks as well. While using this skill in this fashion, the player must move at a slow walking pace, one step per second. The Marshal has final say as to the successful use of this skill.

### Trap Dodge

<b>Build Cost:</b>	4	<b>Purchase:</b>	Multi
<b>Tagged:</b>	Yes	<b>Duration:</b>	Instant
<b>Skill Type:</b>	Dexterity		
<b>Prerequisites:</b>	Rogue Basic Career Skill List, Set Trap Rank 3		
<b>Skill List:</b>	Master Thief		

This skill allows a character to escape the effects of a trap once it has been triggered. The character does not move from the spot they were in when the trap was triggered. The character can dodge a trap even if they were surprised. This skill may not be combined with Dodge, Jump, or any other movement-affecting skill. The character cannot dodge a trap that they intentionally set off.

**True Aim**

<b>Build Cost:</b>	6	<b>Purchase:</b>	Multi
<b>Tagged:</b>	Yes	<b>Duration:</b>	Instant
<b>Skill Type:</b>	Martial		
<b>Prerequisites:</b>	Warrior Basic Career Skill List, 1 Proficiency with a Ranged Weapon ~ or ~ 1 Assassin Proficiency Skill		
<b>Skill List:</b>	Master Warrior, Assassin		

With this skill, the character may hit any target character within line of sight flawlessly without having to actually hit the target. The character must have the appropriate ranged attack in hand and the character must fire or throw the attack. If the character or targeted character is outside a building the missile attack must go at least as far, if not farther than the target. It need not hit or be close, just reach the target. If the character and the target character are inside an out-of-game real world building the range of a True Aim skill is unlimited. The character must prefix the attack with “True Aim...”, and call the damage or effect. The character should indicate the target clearly by pointing at the target.

This skill is always used once called.

**Turn Lesser Undead**

<b>Build Cost:</b>	5	<b>Purchase:</b>	Multi
<b>Tagged:</b>	Yes	<b>Duration:</b>	30 Minutes
<b>Skill Type:</b>	Faith		
<b>Prerequisites:</b>	Detect Undead		
<b>Skill List:</b>	Follower of the Light		

This skill will force all lesser undead and lesser demons within hearing range or line of sight of the character to turn and flee away from them for 30 minutes. The affected characters must turn and move as fast as that type of character is able to move. They are not allowed to take any offensive actions and cannot use defensive skills, but they may invoke latent defenses.

This skill can only be countered by a Servant of Darkness control skill, Empower skill or sorcery; necromancy will not counter this skill.

This skill requires the use of the character’s focus and a verbal, which must be at least 5 syllables, not including the skill’s name, and must contain some reasonably recognizable version of the name of the skill.

**Turn Undead Horde**

<b>Build Cost:</b>	8	<b>Purchase:</b>	Multi
<b>Tagged:</b>	Yes	<b>Duration:</b>	30 Minutes
<b>Skill Type:</b>	Faith		
<b>Prerequisites:</b>	Repel Undead		
<b>Skill List:</b>	Follower of the Light		

This skill will force all undead and demons of any type, within hearing range or line of sight of the character to turn and flee away from them for 30 minutes. The affected characters must turn and move as fast as that type of character is able to move. They are not allowed to take any offensive actions and cannot use defensive skills, but they may invoke latent defenses.

This skill can only be countered by a Servant of Darkness control skill, Empower skill or sorcery; necromancy will not counter this skill.

This skill requires the use of the character’s focus and a verbal, which must be at least 5 syllables, not including the skill’s name, and must contain some reasonably recognizable version of the name of the skill.

**U****Unlife**

<b>Build Cost:</b>	8	<b>Purchase:</b>	Once
<b>Tagged:</b>	No	<b>Duration:</b>	<i>Special</i>
<b>Skill Type:</b>	Faith		
<b>Prerequisites:</b>	Dark Paladin, Cloak Undead		
<b>Skill List:</b>	Servant of Darkness		

Once this skill is purchased, the character’s immunity to being turned into an undead is forfeit. Every time the character is raised as an undead through necromancy or sorcery they gain the characteristics of the undead they are turned into – body and abilities – and will be able to use all of their skills and Servant of Darkness skills as a free thinking character not under the caster’s control. The one exception is Zombies and Skeletons created through the Necromancy School, the character cannot use any skill or ability that requires verbals.

If the character is resurrected, they will retain memory of their time as an undead, but not the act of being animated. This skill will not protect them from skills or abilities that control undead.

**V****Venom Touch**

<b>Build Cost:</b>	8	<b>Purchase:</b>	Multi
<b>Tagged:</b>	Yes	<b>Duration:</b>	5 Minutes
<b>Skill Type:</b>	Faith		
<b>Prerequisites:</b>	Pain Touch, Dark Paladin		
<b>Skill List:</b>	Servant of Darkness		

This skill will contaminate the targeted character’s blood with a fatal, non-alchemical effect, bypassing all armor. The target is paralyzed for 5 minutes and if not cured in that time the character will be brought to the Brink of Death. This effect can only be cured by using the Heal Wounds skill to *Purify Blood*. While under the effects of this skill, the target is surrounded by a sickly green nimbus.

This skill requires the use of the character’s focus and a verbal, which must be at least 5 syllables, not including the skill’s name, and must contain some reasonably recognizable version of the name of the skill. This skill can be delivered by touch or through a weapon. This skill can be blocked by, and is expended by, a magical defense that stops physical attacks or the Resist Evil skill, or a defensive martial skill which is used but does not expend the Pain Touch skill for that Tag Cycle. This effect can only be cured by a Purify Blood cast from a Heal Wounds skill, not the low magic spell.

## W – Z

## Waylay

<b>Build Cost:</b>	5/15	<b>Purchase:</b>	Once
<b>Tagged:</b>	No	<b>Duration:</b>	5 Minutes
<b>Skill Type:</b>	Dexterity		
<b>Prerequisites:</b>	Small Weapon Skill		
<b>Skill List:</b>	Rogue Basic Career Skill List		

This skill will render a target character Unconscious by striking them with a small weapon. The character should tap the target player between the shoulder blades with the weapon and prefix their damage with the word “Waylay”. All Damage Bonuses and Strength Bonuses will add to the damage done by a Waylay. The character must call damage to be effective; a “Waylay Zero” or less has no effect.

This skill must be delivered from behind. The character must be approximately 90 degrees behind their target to be considered behind them. The character cannot reach their arms around the target to use their Waylay skill. A Waylay does not have to be delivered from surprise, but cannot be delivered against a character who is currently engaged in combat. Once a character has been hit with a Waylay, they are considered to be in-combat, therefore you cannot hit the same character with another waylay immediately after. A character cannot Waylay two characters simultaneously even if they have the Florentine skill. Additionally, a character cannot use the Waylay skill with a ranged attack, even if it is augmented by the True Aim skill.

A defense that stops physical attacks will protect the character from both the effect and damage done by a waylay. Additionally, a helmet that covers the back of a character’s head **and** neck will also protect against a Waylay. When armor is evaluated by an Arms Marshal, the helmet is assigned a certain number of Armor Points. In order for a Waylay to knock a character unconscious, it must do more damage than the Armor Points in the helmet. For example, if the target is wearing a helmet worth 2 Armor Points, and you call “Waylay one”, then the target does not fall unconscious but still takes 1 point of damage. The Armor Points in the helmet are the last ones to go for purposes of waylay protection.

In-game, a Waylay should be perceived as a strong, hard blow to the back of a character’s head, accompanied by a meaty “thunk”. It is not possible to make this a quiet attack; the character must say – not whisper – the word “Waylay”; everyone who hears that word knows that a strong blow has been struck.

## Weapon Accuracy

<b>Build Cost:</b>	3	<b>Purchase:</b>	Multi
<b>Tagged:</b>	Yes	<b>Duration:</b>	Instant
<b>Skill Type:</b>	Martial		
<b>Prerequisites:</b>	Warrior Basic Career Skill List, 1 Proficiency ~ or ~ 1 Assassin Proficiency		
<b>Skill List:</b>	Master Warrior, Assassin		

Using this skill, a character can pinpoint the “chink” in their opponent’s Armor, and hit their Body Points directly. The character must suffix the word “Body” after the amount of damage. This notifies their opponent that such damage is to be deducted from their Body Point total. This skill may be used with other damage skills such as Critical Attack and Speed, as well as being an effective way

to deliver blade poisons. This skill will work against mundane or magical Armor Points, even those from an *Armor* spell.

This skill cannot be used with an attack that does not do damage.

This skill is not used if the character misses their target or the attack is blocked. If they succeed in striking their target or if the target calls an appropriate defense, the skill is used.

## Weapon Barrier

<b>Build Cost:</b>	6	<b>Purchase:</b>	Multi
<b>Tagged:</b>	Yes	<b>Duration:</b>	1 Minute
<b>Skill Type:</b>	Martial		
<b>Prerequisites:</b>	Weapons Master, 4 Proficiencies		
<b>Skill List:</b>	Master Warrior, Assassin		

This skill grants the character a 2 Threshold for 1 minute. This skill will stack with itself, so each additional use of this skill will grant the character an additional +2 Threshold up to a maximum of an 8 Threshold. The player must decide when they invoke this skill how many purchases they wish to use; they cannot decide later to increase the Threshold value.

To use this skill, the character must be wielding a weapon. The player should call, “Weapon Barrier, x Threshold”, where ‘x’ is the value of the Threshold. Then about every 30 seconds they should remind everyone they are using this skill by saying, “Active Weapon Barrier x”. If the character should lose their weapon, they no longer gain the benefit of the Threshold. When the character is once more wielding a weapon, the benefit of the Threshold is regained. This same rule applies to the character being rendered Unconscious or forced into a Death Count. Once the character is awoken or healed, the Threshold continues. Finally, if a character is unable to wield their weapon – they are bound, paralyzed or imprisoned, their limb is broken, they are blinded and do not have the Blind Fighting skill, etc. – they will lose the benefit of the Threshold until they are able to wield a weapon again. Note that the 1 minute count continues even if the character is not gaining the benefit of this skill.

This effect stacks only with non-magical threshold effects.

*For example, Scanlon is ambushed by four Orcs. Being alone and without his healer, he decides not to risk being felled by these evil creatures. He invokes two purchases of his Weapon Barrier skill by saying, “Weapon Barrier, 4 Threshold,” and engages the Orcs. One of the Orcs is an Orc Hero and deals 5 points of damage with his weapon and two others are only dealing 3 points of damage. Since Scanlon cannot increase his threshold even though he has a third purchase of this skill, he turns his attention to the Orc Hero and drops him quickly. However, this allows the Orc shaman to hit Scanlon with a Bind spell. Now he no longer gains the benefit of the Weapon Barrier skill and loses his 4 Threshold. The remaining two Orcs are able to easily cut him down.*



**Weapon Proficiency**

<b>Build Cost:</b>	10/15	<b>Purchase:</b>	Multi
<b>Tagged:</b>	No	<b>Duration:</b>	Constant
<b>Skill Type:</b>	Martial		
<b>Prerequisites:</b>	Any Weapon Skill		
<b>Skill List:</b>	Warrior Basic Career Skill List		

When this skill is purchased the character gains a Damage Bonus to their attacks given in the table below.

Weapon Type	Damage Bonus
Small, Thrown, One-Handed, Bastard, Staffs, and Crossbows	+1
Two-Handed, Polearm, Bows	+1.5 <sup>§</sup>

This skill must be purchased for a specific weapon category and cannot be used with other weapons. Additionally, this skill is hand specific and the character must choose whether to apply the Damage Bonus to either their right or left hand when they purchase this skill.

This skill is stackable with itself and all Weapon Proficiencies learned within a specific weapon category are cumulative. So a Weapon Proficiency +4 with Polearm skill would allow the character to cause 10 points of damage with their polearm. Weapon Proficiencies with other weapon categories do not stack with each other.

*For example, Jaygo purchases the Weapon Proficiency +1 skill with his One-Handed Edge skill with his right hand. He would then cause 3 points of damage with his long sword. Later, Jaygo learns the Weapon Proficiency +2 skill with his One-Handed Edge skill with his right hand and a Weapon Proficiency +1 with Small Weapon skill with his left hand. Now, with his Florentine skill, he causes 4 points of damage with his long sword and 2 points of damage with his dagger, so long as he uses his weapons in the correct hand.*

Proficiencies purchased for bastard weapons are also hand specific. The character gains the Damage Bonus when they use the bastard weapon in two hands and with only one hand so long as it is in the hand they specified at the time the skill was learned.

Proficiencies learned with weapon categories do not transfer to free weapons gained. For example, a character that learns the One-Handed Edge skill and Two-Handed Edge skill can also use Bastard Edged Weapons, but their One-Handed or Two-Handed Edge Weapon Proficiencies cannot be used with a bastard weapon. This is also true for bastard weapon skills.

**Weapon Skill**

<b>Build Cost:</b>	Variable	<b>Purchase:</b>	Once
<b>Tagged:</b>	No	<b>Duration:</b>	Constant
<b>Skill Type:</b>	Martial		
<b>Prerequisites:</b>	None		
<b>Skill List:</b>	Warrior Basic Career Skill List, Rogue Basic Career Skill List, Mage Basic Career Skill List		

This skill is broken down into various categories of weapons. The character must learn each skill individually. All these skills give the character the ability to call damage with that weapon type. If a character does not have the appropriate skill, not only can they not call damage, but should the weapon they are holding be struck, they take the damage anyway.

The Small Weapon skill costs zero Build Points and anyone can learn this skill. The character does not have to take the skill if they do not want, but they then cannot use a small weapon. However, any character that learns a weapon skill automatically learns the Small Weapon skill and it is put on their Character Card.

If a character has the One-Handed Edge and Two-Handed Edge skills they can use a Bastard Sword as well. The same is true for the blunt weapons skills.

Weapon skills are not hand specific. A character with the One-Handed Edge skill can use their short sword in either their right or left hand with no penalty. Bastard weapons used in one hand will do one less point of damage than when used with two hands. Two handed weapons of any type must be used with two hands to cause damage but can still be used to block attacks if used in one hand. Any marital parry skill the character has with their two handed weapon can be used while only using one hand.

All weapons fall into one of the listed weapon categories. Any new weapon to the game must fall into one of these categories.

**Weapons Master**

<b>Build Cost:</b>	10	<b>Purchase:</b>	Once
<b>Tagged:</b>	No	<b>Duration:</b>	Constant
<b>Skill Type:</b>	Martial		
<b>Prerequisites:</b>	Warrior Basic Career Skill List, 50 Build Points of Martial Skills		
<b>Skill List:</b>	Master Warrior		

With the purchase of this skill, a character gains the ability to use every form of weapon and shield listed on the Warrior Basic Career Skill List and the Florentine skill. Weapons not listed on the Warrior Basic Career Skill List may be learned at no additional cost when taught by someone with the specific weapon skill or Weapons Master and the knowledge of how to use the weapon.

Additionally, any Build Points spent on weapon skills the character may have are refunded when this skill is learned. So, if a character has One-handed Edge skill, Two-handed Edge skill and Large Shield skill the character would get back a total of 10 Build Points, effectively getting the Weapons Master skill for free.

<sup>§</sup> Note: The bonus is rounded down so one purchase give a +1 Damage Bonus and two purchases give a +3 Damage Bonus.

**Weapon Smith**

<b>Build Cost:</b>	4/6/8/10	<b>Purchase:</b>	4 Times
<b>Tagged:</b>	No	<b>Duration:</b>	Constant
<b>Skill Type:</b>	Miscellaneous		
<b>Prerequisites:</b>	None		
<b>Skill List:</b>	Miscellaneous Skill List		

This skill allows a character to make weapons. The table below outlines what each rank of the Weapon Smith skill allows the character to create.

	<b>Weapon or Special Crafting</b>
Rank 1	Small Weapons
	One-Handed Blunt
	Bastard Blunt
	Two-Handed Blunt
	Spear
	Quarterstaff
Rank 2	Any Shield
	One-Handed Edge
	Bastard Edge
	Two-Handed Edge
	Polearm
	Cold Forging
	Copper, Silver, or Gold Coating
Wire Creation	
Rank 3	Venom Dagger
	Enchantment Quality
	Permanently Alloyed Weapon
	Locks
Rank 4	Bone Crafting
	Venom Sword
	Unshatterable (Dwarven Crafting)
	+1 Damage Bonus (Elven Crafting)
	Mithril Forging

A character can create any number of normal weapons they wish in between Events. The character needs to hand over the appropriate weapon stock – which they can buy from the Treasure Manager – and receives the appropriate weapon card. If a character wishes to make a weapon during an Event, they must spend the indicated time in-game. All special weapons must be made in-game.

For full details on creating weapons see the description under the Miscellaneous Skill List in Chapter 2.

**White Sorcerer**

<b>Build Cost:</b>	3	<b>Purchase:</b>	Once
<b>Tagged:</b>	No	<b>Duration:</b>	Constant
<b>Skill Type:</b>	Faith		
<b>Prerequisites:</b>	Plot Approval, Rank 3 Sorcery		
<b>Skill List:</b>	Follower of the Light		

This skill allows the character to cast white only rituals, gives the character a +5% Casting Bonus to all white and white only rituals and double their Knowledge Bonus for ranks of Healing School.

For more information, see the sections on Follower of the Light Advanced Career and Sorcerer Advanced Career.

**Wounding**

<b>Build Cost:</b>	5	<b>Purchase:</b>	Multi
<b>Tagged:</b>	Yes	<b>Duration:</b>	Instant
<b>Skill Type:</b>	Faith		
<b>Prerequisites:</b>	Dark Cleric		
<b>Skill List:</b>	Servant of Darkness		

Once this skill is purchased, the character gains a Wounding Pool. For each purchase of this skill the character gains 25 Wounding Points. The character may use this to heal themselves and any evil characters' – Servants of Darkness, undead, demons, Dark Acolytes, etc. – Body Points at a rate of one for one. The character may not use their pool to mimic Healing School spells.

The character may also use one Wounding Pool Point to augment the damage of their weapon strike to "Dark" which will do direct Body Point damage to any character, even those only affected by magic. This does not increase the damage done by the attack. The character may use any amount of their available Wounding Pool to deliver direct Body Point damage on a one for one ratio by touch or thrown with a spell packet.

*For example, Raizen the Dark Cleric has five purchases of the Wounding skill giving her a 125 point Wounding Pool. She has used 50 points already leaving her with 75 Wounding Pool Points. During a town battle, she uses 40 points of her Wounding Pool by touch to harm Roselina, saying, "By the Dark Lord's hate, I strike you down, 40 Dark". Roselina falls but others around her heard what happened and begin attacking Raizen. She normally swings 5 points of damage with her sword and uses 1 point of her Wounding Pool per swing to augment her damage. She now swings "5 Dark" and does direct Body Point damage to any character she attacks.*

A character that also has the Dark Paladin skill can increase the damage of their weapon strikes at a one for one ratio with their Wounding Pool up to their available Wounding Pool.

*For example, Tyr is fighting the Ducal Guard. Outnumbered, he decides to increase his damage using his Wounding Pool from 7 points of damage. He uses 3 points of his Wounding Pool with each swing. He now swings 10 points of damage and calls "10 Dark" damaging their Body Points directly. Tyr can use more of his Wounding Pool with each attack to increase his damage accordingly.*

This skill requires the use of a verbal, which must be at least 5 syllables, not including the skill's name, and must contain some reasonably recognizable version of the name of the skill. This skill can be delivered by touch, thrown, or through a weapon. If delivered through a weapon, the targeted character must be struck, and unlike Channeled spells, weapons and shields will stop the attack. If the character misses their target, whether thrown or delivered through a weapon, or the target uses a martial skill to stop the attack, the skill is not used. If the attack is stopped by a Resist Evil skill or a magical defense that stops physical attacks, the skill is used.



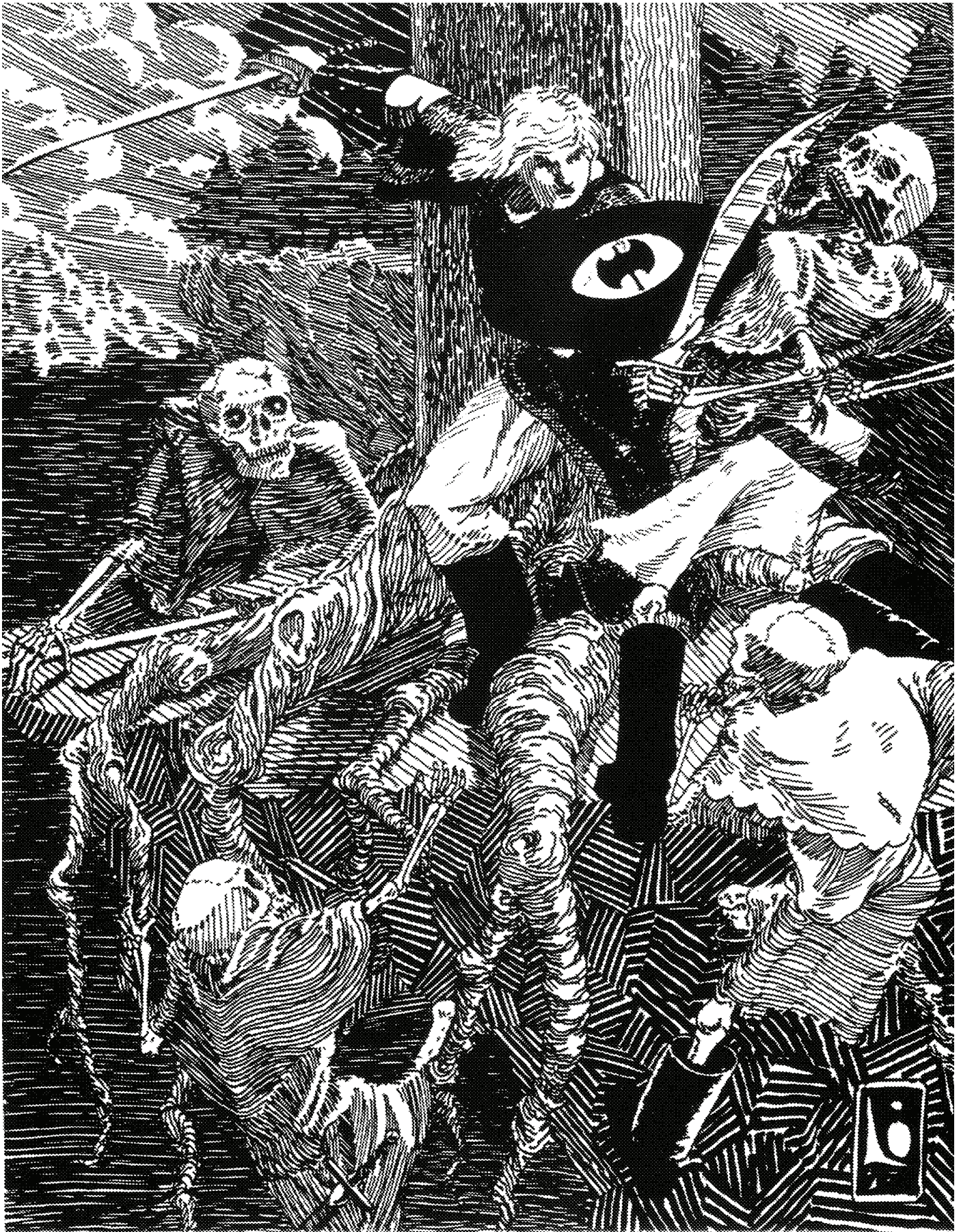



# Chapter 6: Combat...

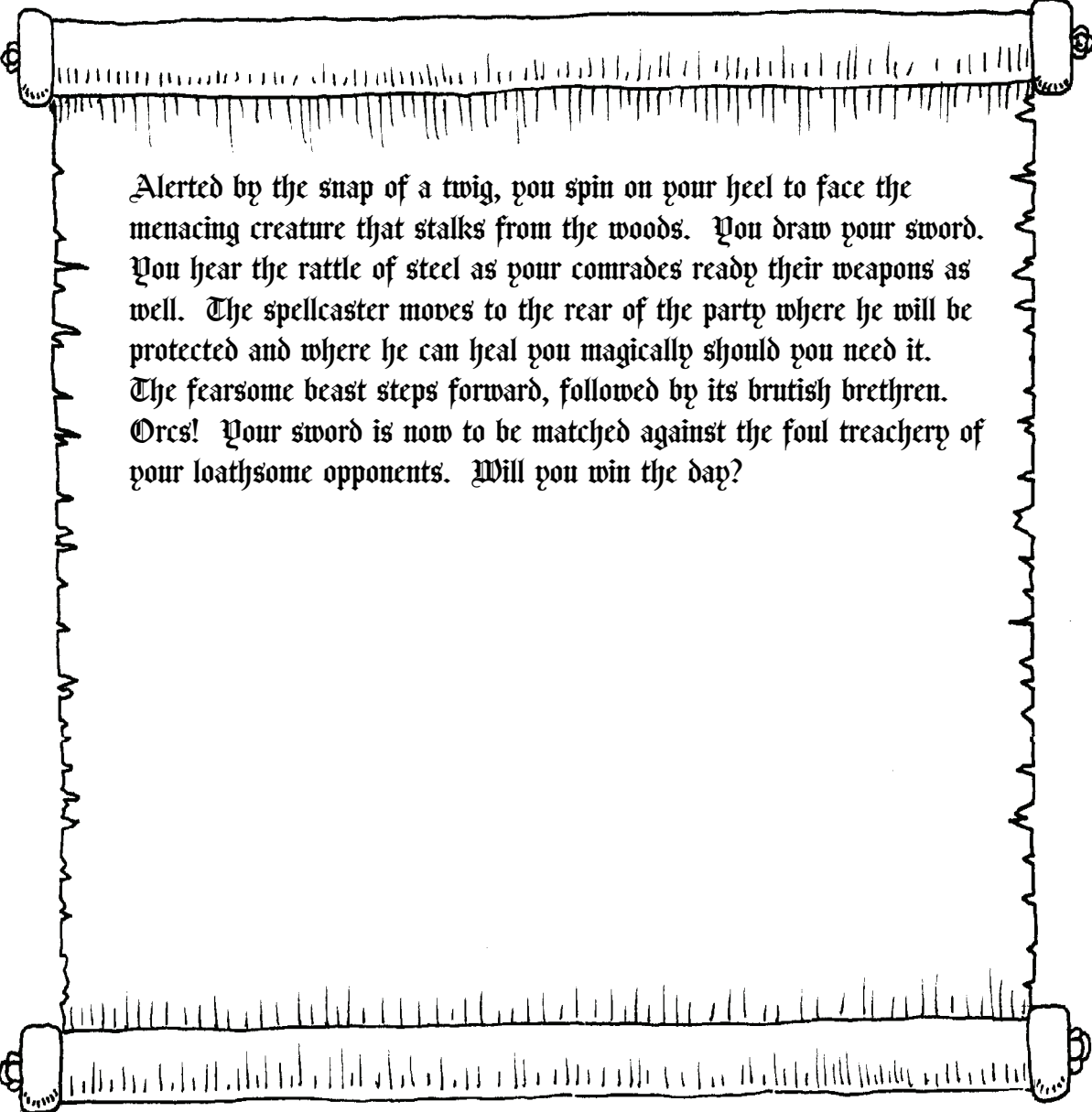

Alerted by the snap of a twig, you spin on your heel to face the menacing creature that stalks from the woods. You draw your sword. You hear the rattle of steel as your comrades ready their weapons as well. The spellcaster moves to the rear of the party where he will be protected and where he can heal you magically should you need it. The fearsome beast steps forward, followed by its brutish brethren. Orcs! Your sword is now to be matched against the foul treachery of your loathsome opponents. Will you win the day?



Combat is one of the most exciting and intriguing parts of the game of LAIRE. At first it seems simple: you just swing a foam sword at your opponent. Then the issue of safety arises, a player has to know how and where to strike with their foam weapon in legal LAIRE combat. Then there is keeping track of how much damage your character has taken during the battle, and all the special blows that can be struck. Combat is not as easy as it first appears.

However, a player who is familiar with all the rules of combat is also the one who has the most fun. The best fighters in the game are those who let themselves feel the rush of adrenaline as they enter melee, but still retain the control over their actions that, in-game, an experienced warrior must have if they are to survive. This balance between knowledge and excitement occurs frequently in the game: A player who knows the rules will enjoy themselves more.

## Combat Rules

### Weapons and Taking Damage

#### *Striking With a Weapon*

You must swing your weapon at moderate speed with moderate force. If you do not have enough time to call damage between each of your swings, then you are swinging too quickly and your blows do not count.

A swing should cover no more than 180 degrees, and no less than a combined 45 degrees with your arm and 45 degrees with your wrist. When thrusting, your elbow should move at least 90 degrees, your elbows should not pass your torso on the back swing, and your elbows should not straighten or lock on the thrust. A “windmill” swing is not allowed. If you swing too hard, you will be warned for excessive force. Repeated offences will result in a combat violation, which will result in your removal from combat for the rest of the Event and a required attendance at a re-education class before you are allowed into combat again.

You must precede multiple thrusting attacks by drawing back for each strike. Nobody ever pierced a breastplate by going poke, poke, poke with their sword.

Adjust yourself to your opponent. Big brawny men in 40 pounds of plate mail are less likely to feel the blow of a foam sword than someone weighing 120 pounds wearing a few wisps of cloth. If someone is striking you too hard, tell them to ease off. The reverse is true as well; if someone is striking you too softly for you to feel through your armor, let them know.

#### *Calling Damage*

When you strike with a weapon, you should call out the damage inflicted by that weapon. The damage done by a weapon must be followed by some modifier; normally this is the word “damage”. For example, if you are wielding a Two-Hand Edged weapon and you have no special combat bonuses, you would call “Three Damage” when you strike an opponent with your weapon.

Even if your attack does not make contact, you may still want to call damage with every swing. You never know if your opponent is going to make an error and your attack may get through unexpectedly. If your attack lands and you do not call damage properly, your opponent does not have to take the damage.

Calling damage is out-of-game. If your character is under the effect of some force that causes the character to be silent, you must still call damage with each blow.

When swinging special weapon attacks, such as the Slay or Disarm skill, you should give your opponent a moment to respond to the attack by either taking the effect or calling a defense. It is a good practice to acknowledge the attack by looking at your opponent and saying “Got it,” or some other similar phrase. This is not required but it will help to alleviate confusion. If you have multiple purchases of a specialty attack you may chain them together, attacking your opponent quickly. **However, if your opponent ever calls more defenses, takes the effect, or any combination of these, than you have current uses of the skills you will receive a rules violation.** For example, John is playing a warrior and has two purchases of the Slay skill. During a fight he hits his opponent four times calling “Slay” each time. The defending character calls “Invulnerability, Slay Parry, Slay Parry, Ritual of Defense”. John is in violation of the rules, he only had two Slays. Another example, John strikes his opponent three times calling “Slay” each time. The defending character calls “Invulnerability, Dodge” then falls down. John is in violation of the rules, he only has two Slays.

#### *Surprise Attacks and Using Martial Defenses*

The only attack skill that is classified as a surprise is the Assassinate skill. A character cannot use a martial defensive skill against a surprise attack. Therefore, if an Assassinate skill is used on a character, they cannot call martial defenses like Master Parry, Slay Parry, Crit Parry, etc. to stop the Assassinate.

An attack delivered by surprise is different than a surprise attack. A character unaware of an opponent who is struck by an attack – damage, martial skill, spell, or ability – can always call a magical defense. They can also call a martial skill so long as they have a weapon in hand. They must be able to use their martial defense with the weapon in hand. A character with a weapon that is sheathed or held under their arm, for example, cannot use a martial skill to stop the attack.

*For example, Zephyr is standing around watching some friends spar. His weapons are in their sheath at his side. A brigand comes up behind him and strikes him in the back with a Slay. Even though Zephyr has a Slay skill that he can parry the attack with, he cannot use it to stop the Slay from the brigand because it is in his sheath. He calls an Invulnerability instead. Later, Zephyr is again standing around waiting for some friends to return. This time, learning his lesson earlier in the day, he has his sword out and in hand. Another brigand quietly approaches Zephyr from behind and surprises Zephyr with a Slay to the back. This time Zephyr calls his Slay Parry and stops the attack.*

#### *Additions to Normal Damage*

You should add any Damage Bonuses you have to the Base Weapon Damage of the weapon you are wielding. For example, if you are striking with a regular long sword you would call “Two Damage” with each blow; if you had two purchases of the Weapon Proficiency skill giving you a +2 Damage Bonus with the long sword then you would call “Four Damage” with each blow.

If your character has the Florentine or Master Florentine skill, then you must call damage with each weapon for each strike. You cannot add up the damage of both weapons in a single blow. Call the damage for each of your weapons clearly; these skills do *not* allow you to swing your weapons twice as fast.

You should only call the damage that your character normally does. If you are aware that a particular attack does extra damage to a type of monster, let the NPC do any special calculations. For instance, Arturis the Warrior carries the legendary Lightning Blade. He knows that the Gelatin Golem he is fighting takes double damage from electrical attacks; still, he only calls “Two Lightning” when attacking and lets the Gelatin Golem’s player double the damage.

### *When You Do not Call Full Damage*

You are allowed to do less damage than your maximum. If your character can call “Six Damage” because you are wielding a two-hand blunt weapon and you have a +3 Damage Bonus, you can choose to call “One Damage” instead. However, if the weapon has any special modifiers, you must state the appropriate modifier for that weapon. For example, if you have a +2 magic long sword and two purchases of the Weapon Proficiency skill, you can call “One Magic” instead of “Six Magic,” but you *must* include the word “magic”.

You do not call damage with certain special attacks. If you are making one of these special attacks, you do not call damage along with the special attack. For example, assume that you deal 5 points of damage with your weapon and have one purchase of the Slay skill. If you hit a player and call “Five Damage,” you cannot use a Slay as well.

### *Taking Damage*

You are responsible for keeping track of the damage that has been done to your character. As you are damaged, you must keep a running tally of how many Armor Points and Body Points you have, and subtract damage from this total as you are struck. Under normal circumstances, you first subtract the damage from your Armor Points; when your Armor Points are gone, you subtract the damage from your Body Points. When your Body Points reach zero or below, lie down; your character is either Unconscious or Bleeding to Death. Please see later in this chapter for more information on death and dying.

**If no marshal is present, the player who is taking the damage, not the one inflicting it, has the final say on how much damage has been taken.** The marshal has final say on whether an attack is successful or not. It is sometimes necessary to make a judgment call when you are trying to decide whether legal contact was made in combat. If you feel a solid blow, then you should take the damage. If someone barely touches you with their weapon, then you do not have to take the damage. If someone is consistently hitting you too softly, let them know. If someone insists they hit you, but you did not feel it due to thick clothing or heavy armor, take the damage honorably, and request that they strike with a little more force.

If you deliberately block or deflect a weapon, then it does not do damage, nor do weapons that strike your shield. However, normal objects do not protect you against a weapon attack. If you happen to have a sheathed sword and someone hits you on that sheath, the blow is not parried; if you feel the blow you should take the damage. **It is illegal to deliberately block an attack with a body part that is not a legal target.**

If you think a player is not taking their damage fairly, then you should report them to a Marshal. Be sure to ask the player about how much damage they thought they took; remember that there are monsters that are immune to the attacks of some weapons. Players who are repeatedly cautioned for not taking damage will be disciplined.

## Special Rules for Weapons and Shields

Bastard swords may be used with one or two hands; the damage varies according to the number of hands on the weapon.

All two-handed weapons, including staves and polearms, must always be used in two hands to score damage in combat. If you wield the weapon with one hand, you cannot do damage with it but you can still block and parry.

Spears cannot be thrown. The only weapons you are allowed to throw are those entirely made out of foam.

### *Claws*

Some characters with a skill or racial ability may use a claw to attack with instead of in-game weapons. A claw is represented out-of-game by a foam weapon wrapped entirely in white duct tape. If your weapon strikes a claw, the character takes damage because the claw is part of the character’s body. However, some character’s claws are so tough they do not take any damage if you hit their claws. The NPC should indicate they have not taken damage when their claws are struck. A claw cannot be affected by a *Fumble* spell or removed with the Disarm skill. In addition, most martial skills such as Proficiencies, Slay, Critical Attack, Assassinate, etc. cannot be used with a claw.

In order to cast a spell, you must hit the person with a spell packet, even if you use a spell packet to touch them at zero range. Therefore, you can never “touch cast” with a claw, no matter who you are. The only way to cast a spell through a weapon is with the Channeling skill. You cannot use a claw to channel a spell since it is neither a weapon nor a weapon of quality. There are no such things as “claws of quality”. All characters in our game conform to this rule, no spell may be cast with the use of claw. Some creatures have spell like effects that sound or act like spells. This is acceptable and is clearly delineated on the character’s card. Also, certain characters with claws may be able to use faith skills and abilities through their claws. This also will be clearly delineated on that character’s card.

### *Shields*

Shields do not add to the Armor Point value awarded a character. They are simply used to block attacks. Unlike armor, shields never “wear out”. A shield can sustain any number of blows struck by any type of weapon. Spells that strike a shield are not blocked and still affect the character normally. However, shields of quality will stop elemental damaging attacks such as spells from the Ice School or Enchantments School.

### *Illegal Combat Maneuvers*

The following combat maneuvers are illegal in the LAIRE rules system:

- Trapping a weapon with any body part.
- Trapping or pinning a weapon with another weapon or against any object at any time. This includes standing on a weapon or roleplaying standing on a weapon.
- Charging, or running at an opponent so fast as to force them to retreat for fear of injury. It is acceptable to run up to an opponent so long as you stop in front of them and do not cause them to retreat.
- Crouching down behind a shield so that you cannot be struck anywhere but in the head; this is called “turtling”. In real combat, a turtled individual could be physically pushed over, but since no physical contact is allowed in combat,

neither is turtling. Standing in a corner with your shield protecting you is not turtling; as long as you present a legal target for an opponent while your shield is in front of you, you are not turtling.

- Fighting in such a way that an illegal combat target becomes highly vulnerable to being struck.

## Legal Contact in Combat

### *Legal Contact in Combat*

In combat, the only physical contact allowed between players is using a LAIRE-authorized weapon. You may not touch an opponent in combat with your hands, not even to cast a spell or administer a poison. You may not grab an opponent's weapon with your hand. A shield is not a weapon; you can use it to parry blows, but you cannot use it to pin a weapon or strike another player.

The following areas of the body may not be struck by a weapon at all: the head, the neck, and the groin. This is a safety issue; if you should accidentally strike a player in one of those areas then they take no damage, and you may receive a warning. Wrists and hands are "semi-legal" targets; it is not a weapons violation to hit those areas, but the target takes no damage as a result. Though the chest is a legal strike area, please exercise extra caution when fighting women.

Apart from the areas mentioned above, all other parts of the body, including the soles of the feet, are legal parts of the body for weapon attacks.

### *Facial Contact*

The head and face are *never* appropriate for any in-game activity, whether it be an attack by a weapon, a target for a spell packet, or the application of an item such as a poison. If you wish to represent facial contact in some way, touch the player's shoulder and say "facial contact" out-of-game.

### *When You Are Struck Illegally*

If you are struck on an illegal part of your body, let your opponent know by saying, "head strike," or whatever is appropriate. If you are struck a second time, call a Hold and explain the matter to the offending player and to a Marshal. You should do this even if you think the second blow was a coincidence. You do not know if the player has a problem systematically striking other people in the head; the Marshal will know if the player has been warned before.

If you are struck illegally and are hurt out-of-game, remember that it is *your* responsibility to call a Hold, not your attacker. Your attacker cannot tell whether you are actually hurt or whether you are roleplaying the damage done to your character. Do not hesitate to call a Hold for your own personal safety; if you have been hit in the head and you think you are all right, call a Hold anyway; sometimes it takes a moment to feel the effects of a nasty blow.

### *When You Strike an Illegal Blow*

If you swing a blow and a player says, "head strike," *always* take their word for it. Even if you think the blow was an accident, treat it as a serious indication that you should alter your style of combat. The most common reason for accidental head strikes is that you are aiming for a player's shoulder and strike their head instead. Do not aim for their shoulder anymore, aim for their torso instead; also remember that the feet and ankles are always legal targets and can be more effective points to aim at in combat than the shoulder.



Important: If a player falls down before you and seems injured, ask. It is *their* responsibility to call a Hold, not yours, but give them a chance to do so. However, if the player fails to respond or you see blood, call a Hold. If you hear them even whisper the word Hold at this point, repeat it with a yell so that the combat will stop. If a player falls down clutching at their head, then odds are they are not roleplaying; ask, "Out-of-game, are you all right?"

### *Restraining another Character*

Sometimes during game play one character may wish to restrain another character for some reason. There is no physical contact allowed between two players, therefore in order to simulate the contact, the restraining character should touch the other character on the shoulder with a spell packet and say, "I grab you with plus <Strength Bonus>, <Location>". For example, if Feiht wishes to restrain Dunadass, he would touch Dunadass on the shoulder with a spell packet, and using his Giant Strength spell, say, "I grab you with plus three strength on your arms."

The target of the grab has three choices. First, they can do nothing and be grabbed. Second, they could call a defense that stops physical attacks, or lastly, can use their strength to resist. In order not to be grabbed, the target must equal the strength used to grab them; in this case, the tie goes to the grabbed. Once grabbed, the character must exceed the strength used to hold them; in this case the tie goes to the grabber.

All Strength Bonuses must be called when grabbed or when being resisted. There is no back and forth escalation of strength contests. If the Strength Bonus comes from a temporary source, such as a spell, then the initial attempt counts as one action. In the above example, if Dunadass was grabbed by Feiht, Feiht would be able to hold Dunadass for 15 seconds with a +3 Strength Bonus from his *Giant Strength* spell.



If for any reason, the target character resists the grab contest and wins, the grabber will have to try again and cannot simply restate the grab. **Finally, no character can grab another character while either is engaged in combat.**

## Killing Blows

To force a character to the Brink of Death when they are Unconscious, Bleeding to Death, paralyzed, asleep, or otherwise totally unresisting, a player must touch the character's torso with a weapon and say, "One Killing Blow, two Killing Blow, three Killing Blow," followed by the damage done by the attack. It is also acceptable to say, "Killing Blow one, Killing Blow two, Killing Blow three," followed by the damage done by the attack. It must take at least three seconds to say this phrase and requires the character to concentrate, therefore they may take no other actions while delivering the Killing Blow. This represents the time it takes for the player to set up the ideal shot that will kill the character. For example, if you are giving a Killing Blow to a character, and you have a long sword and no Damage Bonus, you would say, "One Killing Blow, two-Killing Blow, three Killing Blow, two damage."

A Killing Blow can be administered with a thrown weapon, a bow, or a crossbow. You must count "One Killing Blow, two Killing Blow, three Killing Blow," cast your weapon, hit the target character in the torso, and state the amount of damage done by the weapon. If you should hit the target with the weapon but not in the torso, they still take the damage you called and if they are asleep – in- or out-of-game – the player or character should be woken up.

A Killing Blow can also be given with a magic spell that does damage. The spell caster must say the spell verbal, count "One Killing Blow, two Killing Blow, three Killing Blow," then either hit the character with a spell packet or touch the character's torso with a spell packet, and then state the damage done by the spell. For example, "With pure magic I cast a shock... one Killing Blow, two



Killing Blow, three Killing Blow... four magic lightning."

If the Killing Blow is delivered with a weapon, and the weapon has a special property, you must include the property in the phrase. For example, if you are giving a Killing Blow to a werewolf and you have a silver long sword, you would say, "One Killing Blow, two Killing Blow, three Killing Blow, two silver". Maybe this will not make any difference, but you never know...

You can give a Killing Blow with your bare hands but you must have a Strength Bonus of at least +3 or the Killing Blow Magic skill.

If the player giving the Killing Blow is interrupted while saying the phrase, the fallen character is unaffected. If you are giving a Killing Blow to a player who is sleeping in-game, if they wake up and dodge while you are saying the phrase, then you have not killed their character. If they sleep through the phrase, then their character is dead; wake the player and tell them the bad news.

The reason you must include the damage done when you give a Killing Blow is that there are some monsters that are resistant to damage, or can only be affected by special weapons. For example, a monster with thick, horny skin may be unaffected by blows that do 2 points of damage or less; such a creature would not be harmed by a Killing Blow delivered with an ordinary dagger.

## Severing Blows and Disabling a Character

Sometimes a character – for good or ill – may want to disable a character or even remove a limb.

To remove a limb, a character needs an edged weapon; blunt weapons can never remove limbs. The character should place their weapon on the limb to be removed in the general area they want the limb removed. The player should count to three, "Severing blow one, severing blow two, severing blow three, <damage>." Conversely, the character can try and tear a limb off in the same way, but a minimum of a +6 Strength Bonus is required to remove the limb. If the limb removed is either an arm or leg, the target character is immediately Bleeding to Death. If the head is removed in this manner, the target character is immediately brought to the Brink of Death.

If the character only wants to disable another character without tearing off limbs, they can deliver a disabling blow. The character needs three of the following five skills to do so: First Aid, Autopsy, Battle Surgery, Dissection, or Evisceration. The character can disable limbs, hands, fingers, eyes, ears, or the ability to speak. The character should count 3 seconds saying, "Disabling blow one, disabling blow two, disabling blow three." The target character is immediately brought to 1 Body Point. *Heal Limb* spell or effect will fix any of these effects.

## Special Attacks

There are a variety of special attacks that you may be able to strike in combat. An attack may be special because of an ability your character has, because of a special weapon you have, because of a magic spell that is aiding your attack, or because you are playing a monster with a special power.

Most special attacks are announced by giving the damage caused by the blow, followed by the special property of the attack. However, there are some attacks that do not do damage in a conventional way and so no damage is announced.

The following table gives a list of the most common special attacks found in the game. The damage type follows the amount of damage



dealt when the player swings the attack, for example, “Two Damage”, “Six Magic”, or “Four Paralyze”. These effects are cumulative as in these examples: “Four Body Poison”, “Twelve Magic Fire Crit”, or “Ten Gold Lightning Body Poison”. The order of the modifiers does not matter; “Waylay Magic Three” and “Waylay Three Magic” are the same. Also, never use “Damage” in conjunction with any other special attack. For example, you would say “Five Fire”, “Four Stun”, “Slay”, or “Slay Magic” not “Five Fire Damage”, “Four Damage Stun”, “Slay Damage”, or “Slay Magic Damage” respectively.

### Other Attacks

There are also monster attacks that do not involve direct attacks with weapons (or claws). Here are some of them: Acid, Fire, Cold, etc.: Some creatures have the ability to breathe or shoot substances that do damage. Normally this is represented by the monster NPC tossing a spell packet. The monster NPC would announce the amount of damage and type of substance when they toss the packet. For example, a dragon might call, “Fifty Eldritch Fire,” if the packet hit.

### Parrying for another Character

A character can use a martial skill to parry an attack for another character so long as the parrying character is within weapon’s length of the character they are defending. The parrying character does not

take the effect of the attack.

This holds true for spells thrown at another character. A character can parry a spell for another character using any martial parry skill. However, the parrying character takes the effects of the spell just as if they were hit by it. The parrying character may call a defense that stops spells if they have one to prevent the spell from affecting them.

The only exception to this rule is are the Perfect Aim and True Aim skills. A character cannot parry these attacks when they are directed against another character.

### When the Battle Is Done

When a battle is over, then is the time to hand over your tags to the players you used your skills on. Give any Armor Point and Body Point tags to those who have done damage to you. If you cast any spells, you should give up the Power Point tags for those spells. If

you invoked any spell defenses or magical attacks, hand over the Power Point tags that were used to represent the latent spell. If you used any special attack skills such as Stun or Critical Attack, you should give the tags that represent the use of those skills to your targets.

Of course, be sure to collect tags from those whom you have damaged, those who cast spells at you, those who invoked latent spells, and those who used special attacks. If your opponents were

Damage Type	Description
Damage	This is a normal blow delivered by a claw or a normal weapon.
Metal Alloys: Copper/Bronze Silver Gold Mithril	This means the weapon is made out of a special alloy or has some temporary magical or alchemical augmentation allowing it to act as an alloyed weapon. These attacks do damage to some characters with the Damage Resistance ability on their card. Note that some weapons are only <i>coated</i> with the alloy, and the coating may wear off after a certain amount of time; check the weapon’s card carefully. The order given on the left is the order of precedence for the Damage Resistance ability. For example, a monster that has Damage Resistance: Gold would take damage from gold, mithril and magical weapons but not silver, copper or normal weapons.
Magic	This is a magical blow delivered by a magic weapon, a weapon with a Magic Weapon spell upon it, a Greater Magic Weapon skill, etc. A magic weapon does damage to some characters with the Damage Resistance: Magic ability on their card. Note that some magical augmentations are temporary, so check the weapon’s card carefully.
Elemental: Fire, Ice, Lightning, Life, etc.	This means that the weapon is being augmented by some physical effect, such as fire, ice, lightning, and so on. Such an effect does not make a weapon magical, nor does it normally increase the amount of damage done by the weapon. Some characters take additional damage from such attacks; some characters are immune to such attacks.
Body	The blow does direct Body Point damage, bypassing the character’s Armor Points. This blow may be struck by special weapons or skills such as the Weapon Accuracy skill. Some monsters may be able to damage Body Points directly; you can ask to see the NPC’s card to prove they have this ability.
Rot	The attack does direct Body point damage, bypassing the character’s Armor points and is Necromantic in nature. Physical attacks affect undead normally, however, magical attacks will heal undead characters.
Disease	This blow is struck by the claws of character whose touch causes a disease. The disease will only take effect if the blow does damage to a character’s Body Points; if only Armor Points are damaged then the disease does not take effect. Normally, diseases act like the Necromancy <i>Cause Disease</i> spell; a Marshal will tell you if there are any other special effects. You can ask to see the NPC’s card to prove they have this ability.
Paralyze	This blow is struck by the claws of creature whose touch causes paralysis. The paralysis will only take effect if the blow does damage to a character’s Body Points; if only Armor Points are damaged then the paralysis does not take effect. A paralyzed character cannot move nor speak for 10 minutes (note that this is different from the duration of a <i>Paralysis</i> spell).
Poison	This means that the weapon was poisoned; normally a poisoned weapon is indicated by a piece of green duct tape on the blade. A poison only takes effect if the blow does damage to a character’s Body Points; if only Armor Points are damaged then the poison does not take effect. Also, a poison is normally wiped off a weapon after the first blow that makes contact with a character, so subsequent strikes by that weapon will not be poisoned. If your character’s Body Points are damaged by a poisoned weapon, you should tell your attacker out-of-game, “I’m poisoned”; the attacker will tell you the effects of the poison.

NPC's, you should feel free to ask to see their cards for proof of any unusual attacks or abilities that they used against you as most NPC's do not have tags. After you have collected the necessary tags, turn them into Logistics so they can be reused at a later date. Since we must clean the camp before leaving, please do not throw the tags on the ground; put them in your pocket until you can get to logistics.

## Death and Dying

LAIRE is an action-oriented fantasy game. As such, it is common for characters to live, die, and to be brought back to life again. The number of Body Points your character has tells you the state of health of your character; when your Body Points go below zero your character can die. However, death is not instantaneous, and there are several saving graces that can pull your character back from death's door.

The following chart is a summary of the rules of death and recovery.

Type of Damage	Stage/Status	Time to Heal	How to Heal
BP Reduced to Zero, Waylaid	Unconscious	Will Wake up in 5 minutes and, if originally at zero BP, at 1 BP	Anything that heals a character at least 1 Body Point
BP Reduced to -1	Bleeding to Death	1 Minute	<i>Heal Person</i> , First Aid, Battle Surgery, Healing Potion, Paladin Healing*
Slayed/Assassinated	Mortally Wounded	1 Minute	Heal Mortal Wound Effect
Kill spell, Death Touched, Instant Death poison or Killing Blowed	Brink of Death or Dying	5 Minutes	<i>Life Spell</i> , Paladin Life, Elemental Life, Artifact Life, Draconic Life **

\* This is not an exhaustive list, but a sampling. The skill and spell description will describe how this works.

\*\* Note: Only one type of each of these forms of life can be received per day (7am to 7am). This is not an exhaustive list, but a sampling.

### Types of Injury

There are different levels of injury that your character can sustain. The simplest injury, Body Point damage, can be directly cured with skills and spells that restore Body Points such as: *Heal Person*, Battle Surgery, *Healing Potion*, Paladin Healing, *Soothe Your Wounds*, *Heal* spell song, etc. Whenever you lose Body Points for any reason, you tear off a Body Point tag for each Body Point your character has lost. When your character is healed, the player must give you the Power Point tags, skill tags, or item tags to substitute for Body Point tags.

A character can be injured in other ways than Body Point damage. For example, a limb can be incapacitated by a Stunning Blow, and only a *Heal Limb* will restore it. Special injuries are described under the skill and spell rules that can cause or cure that type of injury.

### Death and Recovery

When your character has lost all their Body Points, you should fall to the ground, lie still, and start your Death Count. If the ground is wet, muddy, or rocky, you can kneel or crouch; just make sure it is clear to your fellow players that your

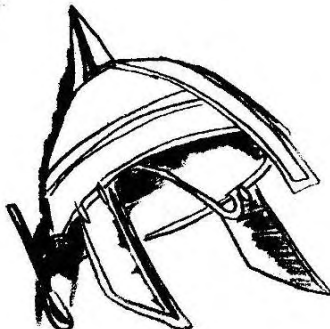

character is down.

Do not talk to other players out-of-game unless it is necessary. If someone asks, "I examine you, what do I see?" it is okay to say, "You see my blood covered body lying here," but you cannot yell, "I need a healing spell" or "I'm going to die in sixty seconds! Someone help me!" If you are counting down the amount of time you have left, do so silently unless someone uses First Aid or casts a *Detect Life* or *Assess Your Ailment* spell on your character. You should not make any noise in an attempt to alert others of your predicament that is called cheating.

No matter how much damage you take, you will never go below -1 Body Points. If your character is at -1 Body Points and you are hit for 10 points of damage, you are still at -1 Body Points. While a character can remove the extremities of a body, the torso is not destroyed with normal damage. After a character is past their Death Count and the player's spirit has not yet left, then things like acid and fire and other destructive effects can destroy a body.

However, characters do not die immediately when they go below 0 Body Points. In summary: a character can be Unconscious at 0 Body Points for 5 minutes, then they will wake up; a character can lay dying at -1 Body Point for 1 minute during which they can be healed; a character is at the Brink of Death for 5 minutes and can still be restored by a life effect such as the *Heal Life* spell; after that a character is dead and must be resurrected by a *Return Spirit* or at the Healer's Guild. So, a character that is reduced to -1 Body

Points will have a total of 6 minutes to receive healing.

### Life Effects

A character may receive one life effect from each category listed in the table below per day (7am to 7am).

Life Effect Category	Example
Low Magic Spell	<i>Life</i> spell, <i>Kill</i> spell on an undead
Faith skill	Paladin Life
Alchemy	<i>Alchemical Life</i> potion
Elemental Life	The ability of a Life Elemental
Artifact	Some ancient and powerful items from antiquity have their own category
Higher Power Life	Draconic Life
<i>Legend Life</i> spell	<i>Special</i>

### Unconsciousness

If a character takes enough damage to go to 0 Body Points, that character is Unconscious. If they are undisturbed, they will revive in 5 minutes and be at 1 Body Point.

A character who has been Waylaid is also Unconscious; if left undisturbed, they will revive in 5 minutes. If they are healed for at least 1 Body Point or First Aid is applied and completed (in other words, the character spends the full, uninterrupted 60 seconds), they

will immediately become conscious before the 5 minutes have elapsed.

Skills and spells that restore Body Points will restore an Unconscious character, if the character became unconscious due to Body Point damage or a Waylay. If a character is unconscious due to a *Sleep* spell or similar effect, then these healing methods can restore the character's Body Points, but will not wake up the character.

### ***Bleeding to Death***

If a character takes enough damage to go to below 0 Body Points, that character is Bleeding to Death. A dying character is considered to be at -1 Body Points, no matter how much additional damage was taken. If your character has 2 Body Points and is hit for 4 points of damage, your character is at -1 Body Points; if your character is then hit by a 24 point *Inferno* spell the character is still at -1 Body Points. A character goes from "Bleeding to Death" to "Dying" if they are not treated within 1 minute of the time they began Bleeding to Death.

### ***Mortally Wounded***

A character is considered Mortally Wounded when they have been affected by a Slay or Assassinate skill. The character is reduced to -1 Body Points, should lie down, and begin their Death Count. The character has 1 minute to receive a *Heal Mortal Wound* spell or a Follower of the Light using their Healing Pool to Heal Mortal Wound, at which time the character is at 1 Body Point. A character goes from being Mortally Wounded to the Brink of Death if they are not treated within that 1 minute.

### ***Brink of Death (Dying)***

A character is at the Brink of Death stage if:

- they were Bleeding to Death and left untreated for more than 1 minute
- they were Mortally Wounded and left untreated for more than 1 minute
- they were given a Killing Blow
- they were hit with a Kill spell or the Death Touch skill
- they were affected by an *Instant Death* poison

A character stays at the Dying stage for 5 minutes. The 5 minutes are counted from the moment the character first went to the Brink of Death stage; for example, if a character is given a Killing Blow while they are Bleeding to Death or Morally Wounded, the 5 minutes is counted from the time when the character received the Killing Blow.

Any life effect is only effective if the character is at the Brink of Death. If a character receives the Life inappropriately, they have not used their chance to receive that type of life later on that day, however, any Power Points are used and any magic item or power is expended. The only exception is the Heal Life skill or Death Touch skill used to life; these are not expended for that Tag Cycle until actually used.

When the character is brought back to life, they are restored to 1 Body Point. See the description of Life spell in the Magic chapter for more information.

### ***Death***

After the 5 minutes have expired, the character is Dead. Only a *Return Spirit* spell or the Healer's Guild can restore the character to life. In either case, the death is recorded on the character card and the Death System must be used to see if the character has been successfully resurrected. When a character is resurrected in this way,

they are restored to their full Body Points. A *Return Spirit* takes a full 10 minutes to cast; if the caster is interrupted during that time, the spell has failed. See the spell's description elsewhere in this book.

*Return Spirit* or resurrection in the Healer's Guild will only work if the target character is willing to be resurrected. You cannot force a character to resurrect.

Any spells that the character was under the effects of, including latent spell defenses, are gone should the character resurrect in the Healer's Guild without their body. On the other hand, if the character receives a *Return Spirit* spell or their body is brought to the Healer's Guild and resurrected, all the character's spells and any other effects will still be present when the character resurrects.

### ***Killing Blows***

To force a character to the Brink of Death when they are Unconscious, Bleeding to Death, paralyzed, asleep, or otherwise totally unresisting, a player may deliver a Killing Blow with a weapon, spell or hands. Note that hands can only be used in this one specific case are not allowed to be used in combat normally.

See the prior section on Killing Blows for more information.

### ***After Your Character is Dead***

If your character is dead, you may remain lying in the spot where your character fell for as long as you wish. Your soul can remain within your body indefinitely. As long as your character's soul remains with its body, you must continue to lie at the spot where your character fell. You may wish to stay at the spot for several reasons: you hope to receive a *Return Spirit* spell; you want your body to serve as a warning to others; you have decided that you do not want your character to be resurrected and you are hoping for a funeral, and many other possible reasons.

When you decide that you have waited long enough, you can become a "spirit". Put on a white headband and go to the Healers' Guild.

If your character is dead and unresurrectable, then the character's body cannot dissipate. The player may play the body for as long as they wish. If the player does not want to play the body any longer, then a suitable physical representation for the body must be found. Such a representation must be approved by a marshal. The body will still decompose at the discretion of Plot.

When you decide to travel out-of-game to the Healers' Guild to be restored, you become a "spirit" or "wandering soul". The only in-game activity you can perform while a spirit is to go to the Healers Guild to be resurrected. There can be no form of in-game communication between a spirit and any other character. **Spirits may never "phase" or pass through another character and will never produce any in-game effects by their passing. A spirit cannot make others feel anything like cold, or sad or malcontent in any way. A character cannot juxtapose themselves to another character and give them chills or haunting feelings, EVER! A spirit cannot affect the game world in any way, shape or form!**

However, there are several out-of-game activities you may have to perform before you go the Healers Guild. First, you must put on a white headband to indicate that you are out-of-game and your body completely dissipates, leaving nothing behind.

Next, leave all your LAIRE items at the spot where your character died, including your money, gems, jewelry, potions, scrolls, and magic items. The only exception is when your character has been killed in an out-of-the-way place and you think it unlikely anyone would ever come to the spot for the rest of the event; in that case,

leave all your stuff anyway and tell a Marshal where you died before you resurrect. You may leave your personal weapons and armor where you died or take them to the Armory or the Merchants Guild, but leave the tag at the spot where you died. You are not required to leave your personal costuming and items where you died, however if you wish, you may.

If you had any magic items or magic weapons, you should leave the physical representation of the item at the spot where your character fell, but go to the Treasure Manager to give them the magic-item cards. If you are absolutely certain that no one would find the magic item where your body fell, then you can give the item to the Treasure Manager instead of leaving it lost in the woods. But be sure; if the item was important, there may be teams of adventurers scouring the woods looking for it, and they should have their chance to find it.

Once you have disposed of all of your in-game possessions, go to the Healers Guild. When your “soul” arrives, lie down or sit and wait for a healer; they will know what to do next. If your “soul” arrives at the Healers Guild with any in-game items, your items will be taken and given to the Treasure Manager.

## The Body, Spirit, and Soul

When a character reaches the end of their Death Count and the player decides to put on a white headband, the character must go to the Healers Guild to resurrect. Before the Death System is discussed, the player should understand the difference between the body, spirit and soul.

Every sentient character in the game has a body, a spirit and a soul. The body is the physical, corporeal, tangible manifestation of the character in the game world. The soul is the essence of the character, all their memories and personality, their experiences and skills are part of the soul. The spirit is what binds the two together.

Every soul is unique and eternal – though there are powerful magical effects that can destroy a soul forever, the soul on its own will exist forever. The soul is who the character really is. When a character dies their final death, their soul is judged and goes to its final rewards. The souls of some characters are reincarnated and born again and again, each time their memories of their past lives are lost or suppressed. Some souls become lost and forgotten and wander the world in search of their hereafter.

The spirit is also immortal and eternal but is not unique. When a person is born, their unique soul merges with a spirit from the Lands of the Dead and life is created. When a character dies, their spirit goes back to the Lands of the Dead, the body dissipates and their soul goes to the Healers Guild. When a character can no longer resurrect, their spirit stays in the Lands of the Dead to “recharge” and waits to merge with a new soul. The rigors of life drain the power a spirit has to hold a soul and body together. Every time a character dies the spirit is weakened. This is represented in the Death System by black marbles – one for every level and one for every death. While the spirit is holding a body and soul together it takes on the aspects of the character’s soul – their personality, emotions, skills – which is why when the Lands of Dead are visited you can meet people you knew. Most of the time, a spirit is not given enough time in the Lands of the Dead to regain its strength and people are born with weak spirits; spirits that effectively have less than 20 marbles, maybe only 1 and therefore their first death is their last death.

However, there is another magical force in the game that can hold a soul to a body, Necromancy. When a necromancer turns a character into an undead, they use the Necromantic magic to act as a spirit. The lesser spells such as *Create Zombie*, *Skeleton* and *Ghoul* are too

weak to allow the soul’s personality to come through and a mindless creature is created. Dark Sorcerous rituals, however, draw upon more powerful Necromantic magic and create greater undead with a twisted evil version of the soul’s personality animating the dead corpse. Either way, the soul – if not evil to begin with – is tormented by their undead state and becomes evil.

## The Death System

When you are resurrected with a *Return Spirit* spell or at the Healers’ Guild, you must check to see if the resurrection was successful. You pick from a bag of twenty marbles, each of which is black, white, or red. The number of black stones in the bag is one for every death you have had in the past not counting uses of the *Heal Life* spell and not counting your “current” death, and one for every level. A single black marble is replaced with a red one in the bag when you are Level 10 or higher, and then enough white stones to make a total of twenty marbles.

If you pick a white marble, your character is resurrected successfully. If you pick a black marble, the resurrection has failed; you cannot bring your character back into the game without turning in 5\*(number of black and red marbles) in Brownie Points. If you pick a red marble, the resurrection has succeeded, but this is your last life. All of your white marbles become black marbles. If you die again, you are dead permanently and become unresurrectable. If you reach zero white marbles and you have not reached Level 30, then your character has one chance left to resurrect, you have to pull a red marble. If you fail to pull a red marble – instead pulled a black – you cannot brownie your character back and you have died your final death and are unresurrectable. There are some means in the game, magical or otherwise, that automatically resurrects your character regardless of your chances; if you only have a red marble, your character is still technically resurrectable and those methods will work.

The one exception to these rules is your character’s first death. Regardless of what level your character dies at, be it Level 1 or 41, you will **always** resurrect. The player does not pull a marble on their first death.

If a character is unresurrectable and they die, their body does not dissipate. If their body is destroyed they cannot attempt to resurrect and their body is lost forever. However, this death is recorded on the character card.

If the “resurrection bag” is not available, and the player whose character is being restored agrees, any convenient means may be substituted for the resurrection bag; for example, a 20-sided die could be used.

No matter which color stone you pick, your death must be recorded on your character card.

*Game hint:* At any given time, if you do not have enough Brownie Points saved to bring your character back to life, you are taking a big risk. If you pull a black marble, you will not be able to play your character until you have earned enough Brownie Points to pay for the resurrection; if your character is killed 5 minutes after an event begins, you may have to play an NPC for the remainder of the event to earn enough Brownie Points. Therefore, we suggest that you earn the Brownie Points before you play your character; this is one reason why we suggest that all new LAIRE members start by playing NPC’s for at least one Event.



### *How to Resurrect a Character*

First, a character must learn the process in-game and have the ability noted on their Character Card. In order to resurrect another character, a character must have learned Rank 3 of the Healing School, or have a skill that allows them to life, for example, the Life skill, *Legend Life* spell song, or even the Death Touch skill as it can be used to life in certain circumstances. Meeting one of these criterions allows the character to see a dead character on Consecrated Ground. However, neither character can communicate in any way to each other. Neither party can speak or gesture or pantomime any kind of information. In-game, perception and therefore information is distorted between a soul and a living person.

Meeting one of these criterions allows a character to see a soul on Consecrated Ground such as is found in the Healers Guild. The character can only see the face clearly. Consecrated Ground should not be confused with an area that has been blessed or Sanctified by one of the three faiths. The House of the Sun, for example, is Sanctified to the High Lord or the Druid's Grove is Sanctified to the Mother. These areas have their own special rules and the player must learn about these in-game. Anyone who can resurrect can teach another character how to do it so long as that character can see souls.

In order to perform the resurrection, the character should touch the dead character and say, "I draw upon this Consecrated Ground to bring this person back to life," or something similar. The verbal need not be exact, but should be clear what the character is doing to anyone listening. Also, this verbal is in-game and should the character not be able to speak, they cannot begin the Resurrection. The character performing the resurrection needs to be standing on the ground or touching it in some other way for this to work.

Next the player performing the resurrection should ask the player of the dead character if they wish to resurrect. A player cannot be forced to resurrect their character. If they are willing, then the player should pull a marble from the bowl. The player should not look at the stone and only show it to the player performing the resurrection.

Then the resurrecting character gives a descriptive story detailing the spirits' journey from the Lands of the Dead. The player may not ask for any information about the dead character to customize the story; they may however use whatever in- or out-of-game knowledge they

have to make the story more personal. Also, the dead character can volunteer any information they wish and it does not have to be the truth either.

Neither character will remember the events that take place during the resurrection. In-game, the resurrecting character sends their soul to the Lands of the Dead to find the lost spirit and brings it back to the Consecrated Ground. This journey to the Lands of the Dead is never remembered by either party.

The resurrection itself takes about 10 minutes to complete. Once the resurrection begins, the resurrecting character is oblivious to their surroundings and cannot interact with it in any way. If the character is interrupted by either taking damage or having their hand removed from the dead character they immediately wake up and can act normally. Nothing bad happens to the dead character should the resurrection be interrupted. The resurrection simply starts from the beginning again when the resurrecter is ready.

Those witnessing the resurrection will see the vague outline of the dead character glow a rosy pink and a body forming out of the ground. When the resurrection is over, and it is successful, the dead character is now alive and their body is fully formed. The character is not yet ready to play, for the stress of returning from the dead leaves the character and their body (new or otherwise) in pain. The character should roleplay this discomfort as they see fit. The newly resurrected character has to take 10 minutes before they can function normally. During this time, they can speak and move very slowly. They are unable to use any skill or ability and cannot fight at all even to parry, but they may invoke latent spells or skills.

The last bit of out-of-game bookkeeping is done at the end of the resurrection when the healer marks the death and the color of the marble pulled on the Character Card. Additionally any Brownie Points spent on buying off a black marble resurrection should be crossed off.

If a character pulls a black marble and does not have the Brownie Points to bring their character back, the body is still formed and is dead. A character on their last death that tries to resurrect will create a body that is dead. This can be tried only once.

The character performing the resurrection does not gain any information as to how many black marbles the dead character has. There is no difference in trying to resurrect a first level character or a thirty first level one. The dead character however, knows how hard it was to come back in-game and knows if they can resurrect again vis-à-vis a resurrection.

### *Resurrection Story Sample 1*

"You awaken to the sound of birds singing outside the window to your small cottage. You sit up and stretch, soaking in the rays of sunlight streaming in through your open window as a gentle breeze flaps your curtains and wafts in the smell of spring flowers. Slowly you draw yourself out of bed and get yourself ready to face the new day.

"Finished with your morning ritual, you move out the door and into the morning. The clean, bright field outside your house is alive with the dance of nature's creatures all busy at their own tasks, seemingly unaware of your intrusion into their world. You head over to the well near the house and draw forth a bucket of fresh water and satiate your morning thirst as a majestic white stag bounds across your view.

"As you look around a feeling of something being amiss, a feeling that has been growing since you awoke this morning

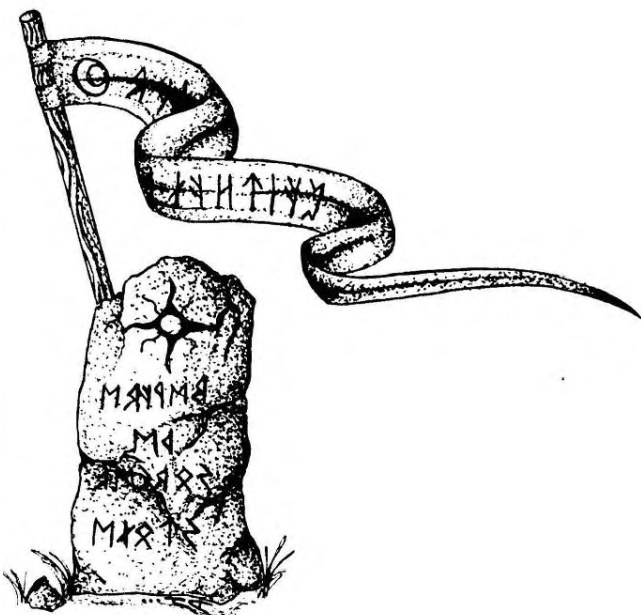

grows ever stronger. The once gentle breeze grows to a strong wind blowing the smells of fires and food from the north. You turn and look at your house which no longer feels familiar or safe, but has taken on an air of mystery and almost foreboding. All is not as right as you first thought. You slowly realize you do not belong here. You turn north and quickly head away, fearful the owner of the house will return and find umbrage with the intruder who has used their house. You quicken your pace and then begin to run with all the speed your legs will take you.

“Your lungs burn with the need for air and your legs ache from running. You slow and pant, walking on through the fields of wheat and corn you have found yourself in. You hear a snap and turn behind to see what is following you, but you see nothing. You have a sense of being followed, of something malevolent stalking you. Not wanting to startle the animal – for that must be what it is – you move on ahead.

“There it is again, the sound of something behind you moving through the field, just far enough back that you cannot see it, but close enough that the sounds of its passing warn you of its imminent attack. You can hear the heavy, harsh breathing of the creature which must be of terrible size. A sense of panic grows within you and then you hear the sound of soft music playing ahead. The sky has turned dark with storm clouds and the smell of rain has mixed with the aromas of food and fire from up ahead. You must not be far now.

“You break out into a run and tear through the field at the same time the monster behind you lets out a low, rumbling guttural growl ending in a harsh bark. The creature must be some kind of dog or wolf. You imagine the creature with large white fangs dripping with its copious drool and its hot fetid breath panting past its large red tongue. The creature – stepping out of the pages of one of your childhood stories – surely has a thick, dirty black coat, matted in places by the dried blood of its past meals.

“You run, it follows. Finally, you burst from the field and see a large gothic mansion ahead of you. Dreary light seeps from the window and the muffled sounds of a party reach you, barely heard over the pounding of the blood in your ears. Running to the front door you pound on the door begging to be let in. Knowing it foolish, you look over your shoulder and there, heading terribly fast towards you, is the monstrous wolf from your nightmares glimpsed only for a moment in the flash of lighting that cracks from the storm clouds above.

“Then the door opens and a butler asks you your business here. You push past him and point out the door, pleading with him to close the door. You both look outside, for surly the hound is at the door, but there is nothing out there. You poke your head outside and look around. Nothing, the night is empty and there is no sign or sound of the creature that has chased you all day.

“The butler asks you your name and says you have been expected. He indicates that you should follow him and he leads you to a great room filled with people of all walks and stations of life. You turn to ask who the host is and why you were expected, but you only catch a glimpse of him as the two great doors close leaving you to the party.

“The aromas of food and fine drink come from a far table and the warmth of two large fire places quickly takes your mind off the mystery and on to more important things. You make your way to the buffet table and take a generous helping of several of the offered dishes and a big mug of your favorite drink, which the host just happens to have. You sit and clean your plate and drain your drink. Still you hunger and decide to take more. A few of the other guests look at you and shake their head at your obvious display of gluttony. You finish two more plates of food and are now hungrier than you were before you started. Confused you put aside your thoughts of food and try and find your way out of this place.

“You move about the room looking for the exit. You find none. The door you know you entered in is gone. You ask your fellow guests how to leave, some laugh, but most just politely ignore you. You grow frustrated. Then you hear your name called from the other side of the room. You head over to the source of the call but the crowds make your way difficult. Again you hear your name called. You grow closer. The crowd has started to grow excited about the arrival of the host. You hear your name again, but this time the person looking for you has moved elsewhere. If only you knew who it was.

“You yell out “HERE!” but the crowd is too loud. You hear your name but cannot tell from where it came. “HERE!” again you shout just as the crowd goes silent and turns to one end of the great room. You turn and look, curious as to whom your host is, maybe they have some answers. The large red curtains move and part slightly allowing the monster that chased you through the fields to step out, this time its teeth red with the blood of a fresh kill. You panic. Are these people crazy?

“You try and back away but no one will move out of your way. The monster howls and a chill runs down your back. You are transfixed with fear. The beast leaps into the crowd which quickly parts and makes way for their “host”. The guests part and bow to the monster which has its gaze and hunger fixed on you. Slowly it comes forward, inexorably moving towards you. Now you know its name. Death, and nothing can stop it. “Death comes for us all,” you think. This is it, the end. The monster is close and its head rises and glares into your eyes.

“Then a hand grabs your shoulder and whips you around. The face is familiar but you can’t recall from where. It calls your name and says, “I’ve looking everywhere for you! Quickly, this way!” You are pulled off away from the beast which growls and lets out a soul chilling howl that threatens to drop you dead from fear. Your guide leads you quickly out of the hall and into a side corridor, one that was not there minutes ago.

“You arrive at what looks like a closet in the side of the hall. “Here it is, always different each time!” he says. Just as he fiddles with a key taken from his pocket in the lock of the closet, the beast turns the corner and calls your name. Death wants you and does not plan on letting you go. “Got it!” exclaims your new friend and throws open the doors. “This way,” he says and enters the closet, reaching out to you with his hand.

“Death moves forward and says “You are mine, and I will have you one day. I follow in your shadow always!” Then

your new friend grabs your hand and brings you into the closet. You finally turn and look inside wondering what you are doing in a closet, but instead of clothes, you see a glowing portal which you are pulled towards. Your guide steps through saying, "I can only lead you here you have to come through on your own." You hesitate then feel Death breathe its rancid breath over your shoulder and before it can utter another word you leap through the portal.

"You find yourself lying on the ground in the Healers Guild. Pain courses through you as your body finishes reforming. You realize you have died. The pain and shock of coming back to life wipes away the memories of your time in the Lands of the Dead."

### ***Resurrection Story Sample 2***

In this sample, the dead character was killed in a big town battle and later turned into an undead. It was late at night and raining. The person doing the resurrection is aware of the basics of what happened.

"You awaken in a small cave. Funny, you don't remember falling asleep here or going into a cave for that matter. Slowly you stand up and stretch. The cold, hard stone floor has left you sore and still tired. As you try and shake the cobwebs of sleep from your head, you begin to remember troubling dreams.

"You move out of the small cave into a large antechamber of some kind, partially carved, partially naturally formed from the rocks of the larger cave walls. You see other people milling about, also looking quite confused. Another flash of memory of some fighting and darkness and rain jumps into your memory.

"You decide to go and ask the other people standing there where you are. No one knows and everyone you talk to does not remember coming here, just like you. There is but one exit from this room and several people have already left. You follow.

"The corridor quickly grows dark, and now that you think about it, you don't remember seeing any torches or lanterns in the last room. As you turn and go to check, the corridor dead ends behind you. Something definitely strange is happening around here. Your heartbeat quickens and you move forward.

"Suddenly you are on a battlefield and fighting a large number of undead. You go to draw your weapon and find it missing. You panic and look around; you are almost surrounded by the undead. The rain pours down on your hair into your eyes. You hear the quick 'splash splash' of running behind you and you quickly turn to see a large Death Knight bringing up his two handed sword and swinging it back down again onto your head. You cover your head with your hands unable to do anything to stop it.

"You wait forever for the blow to be struck. After a long time you move your hands away and you are back in the tunnel and dry. No undead to be seen anywhere. You remember that fight. It was hard and Avalon was losing, but you can't remember what happened. Disoriented, and with a growing sense of fear, you continue down the tunnel.

"After walking for a long time, you see a light up ahead and eventually stumble into a large room with a pit in the

middle, overflowing with the bones of the long dead. The pile goes to the top of the ceiling, to a hole in the roof of the cave. Then, you hear your name called from above. With fear and some hesitation, you move to the pile and begin climbing. The pile is not steady and you slip and fall several times. The skulls of the long dead stare at you from lifeless eye sockets. A rib cage gets stuck on your foot and you quickly flick it off. Again you hear your name, but fainter this time. You move more quickly but the pile shifts and a rain of bones tumbles down over you. You stop, waiting for the sounds to stop, but they don't. You look down over your shoulder to see several skeletons with hateful glowing red eyes crawling up the pile. The bones under you shift and a skeleton begins to pull itself up out of the pile reaching for you. You panic and crawl faster up the pile. Now there are dozens of skeletons coming for you. You are surrounded.

"You finally reach the top of the pile and you begin carefully reaching for the hole. Then something grabs your foot. You panic as this familiar raspy voice calls your name. You look back to see what has you and stare into the lifeless milky white eyes of a zombie, a zombie that looks just like you.

"A scream leaves your throat unbidden and you lunge for the hole after kicking your foot free. The sounds of the undead grow closer as they reach the top of the pile of bones. You find yourself running down a tunnel along a black river. Whomever was calling for you before is nowhere to be seen.

"Tired and out of breath, you reach a small underground beach with a line of people standing in front of a small long boat with a single figure dressed in tattered and dirty black robes. In one hand he holds a long pole used to push the boat, his other black gloved hand is held out as each person in turn drops a coin into his hand and steps on the boat.

"Frantic that the undead are behind you still, you run to the front of the line. A hand reaches out and calls your name. The person, though familiar to you in some way, is trying to hold you back, hindering you and you pull away. You reach the man in robes and ask him to let you on the boat. He says nothing. With no coin in your pocket, you push past him and try and get onto the boat. A hand as hard as steel grabs your shoulder and pulls you back. You look up and see into the cowl of his hood a skeletal face staring back at you. The creature admonishes you and you retreat from his fearful gaze.

"Again the person holds you and calls your name. They tell you to follow. At a loss for any other options, you follow. They lead you away from the beach and down yet another dark corridor. This one quickly ends at a shimmering portal. The guide tells you home is through there and steps through leaving you alone to decide what to do. Finally, with no other option, you step through the portal and find yourself lying on the ground in the Healers Guild. Pain courses through you as your body finishes reforming. You realize you have died. The pain and shock of coming back to life wipes away the memories of your time in the Lands of the Dead."

## Weapons

It is important that every player who wields a weapon knows how to design and construct a foam weapon. Even if you do not make your own weapons, you should know what is inside the foam weapon you hold, and whether or not the weapon satisfies all the LAIRE safety requirements.

### How to Make a Weapon

All weapons must be constructed according to the weapon guidelines given below. Different types of weapons require different construction techniques. The sections below will show you how to make various kinds of weapons found in our game.

Please read this entire section before attempting to make a weapon. Read each step carefully and follow the directions given.

#### Construction Materials

You will need the following things to construct your weapon. All of these items may be found at a good hardware store. Foam pipe insulation is sometimes difficult to find. Frost King™ is the only known reliable manufacturer of foam pipe insulation. If your local hardware store does not carry the correct type, ask them if they would be willing to special order some for you. Most smaller hardware stores are more than happy to help. Also, LAIRE may have weapon construction materials available at Events for purchase.

- A length of ½-inch PVC or ¾-inch CPVC pipe. Note that CPVC and PVC are not quite the same thing: ¾-inch CPVC has an *outside* diameter of ¾ of an inch; ¾-inch PVC has an *inside* diameter of ¾ of an inch. This would lead you to believe that CPVC fits smoothly inside PVC; sometimes it does, but not always.
- A package of 5/8-inch thick foam pipe insulation, also called closed cell foam. 5/8-inch is the minimum thickness that may be used. Use the dark gray colored foam; never use the thinner 3/8-inch foam. You can use this foam for either ½ inch or ¾ inch pipe. You may cut the foam's diameter down to fit the pipe snugly.
- Open-cell foam, the soft foam found in most pillows and cushions. This can be purchased at craft and fabric stores.
- A roll of 2-inch duct tape.
- Strapping tape. A layer of this under your duct tape will strengthen your weapon and lengthen its life. Do not overdo it; a single layer of strapping tape is enough.
- A saw, hacksaw, or pipe cutter to cut the pipe. PVC and CPVC come in 10 foot lengths; the hardware store will usually be willing to cut the pipe for you, but you will probably still have to buy a full 10 foot length.
- A razor blade and/or sharp knife and scissors
- A ruler, a pencil and a marker.
- Sandpaper or a file to smooth any rough edges after cutting the pipe.

Additionally, these items can help customize a weapon, though they are not necessary for basic construction:

- Smaller-diameter PVC pipe or wooden dowel to reinforce the tubing of long weapons. At the hardware store, test

whether the reinforcing dowel fits closely within the pipe you are using for the main body of your weapon.

- Colored cloth, duct, or electrical tape. Standard duct tape is usually gray or black, but you can use other colors of tape to "trim" your weapon. Note that white is used to indicate claws on small weapons and green tape indicates poison or venom blades.
- Indelible marking pen.
- Plastic gems or other ornamentation.

The following list contains the only approved materials that may be used in the construction of a weapon:

- ½-inch PVC or ½-inch and ¾-inch CPVC for Claws and Daggers.
- ½-inch PVC or ¾-inch CPVC for 1-Handed Edge, Blunt, or bastard weapons.
- ¾-PVC for Polearms and Staves, or ½-inch PVC or ¾-inch CPVC with a reinforcing wooden dowel for Polearms and Staves.
- Open cell foam.
- Closed cell pipe foam of at least 5/8-inch thickness but not more than ¾-inch thickness.
- Stiff closed cell foam for cross guards or hand guards.
- Strapping tape, duct tape, gaffers tape, electrical tape (for decoration use only), silver tape, and Mylar tape (for decoration over duct tape).
- Gems of reasonable size on non-striking surfaces. No more than 6" up from the crossguard.
- Cloth on non-striking surfaces.
- Leather or sports grip for the handle.
- 14 gauge or higher wire for handle only.
- Laces, cording or piping for handle only.
- Wooden dowel for eliminating whip or as a counterweight in the handle. Wooden dowels cannot be longer than the handle when used as a counterweight, not counting the thrusting tip. A small finishing nail must be used to prevent the dowel from sliding down the blade. Glue can be used to hold the dowel in place.
- Glues and adhesives.
- Paints or coloring that permanently adhere to the weapon and does not come off through normal use.
- Other materials maybe used upon approval by no less than 2 approved arms Marshals.

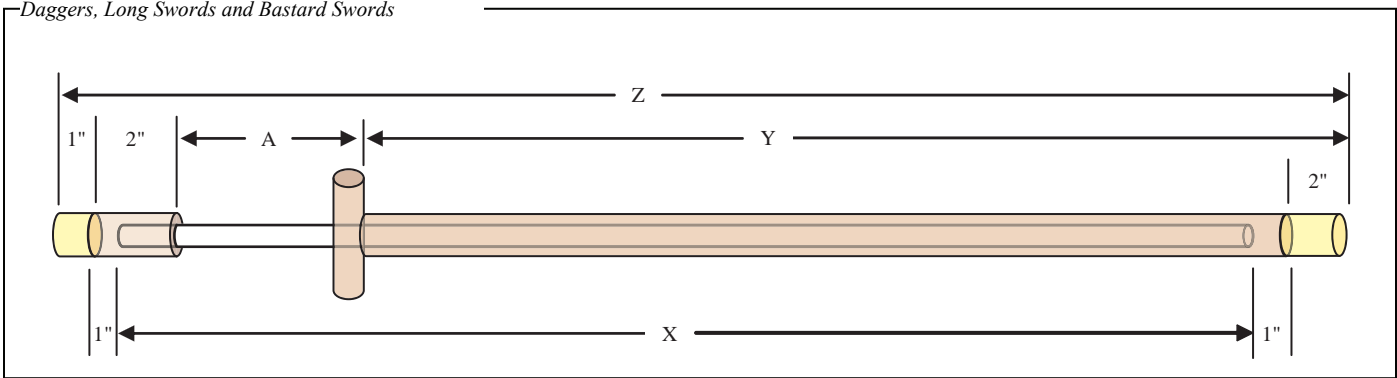
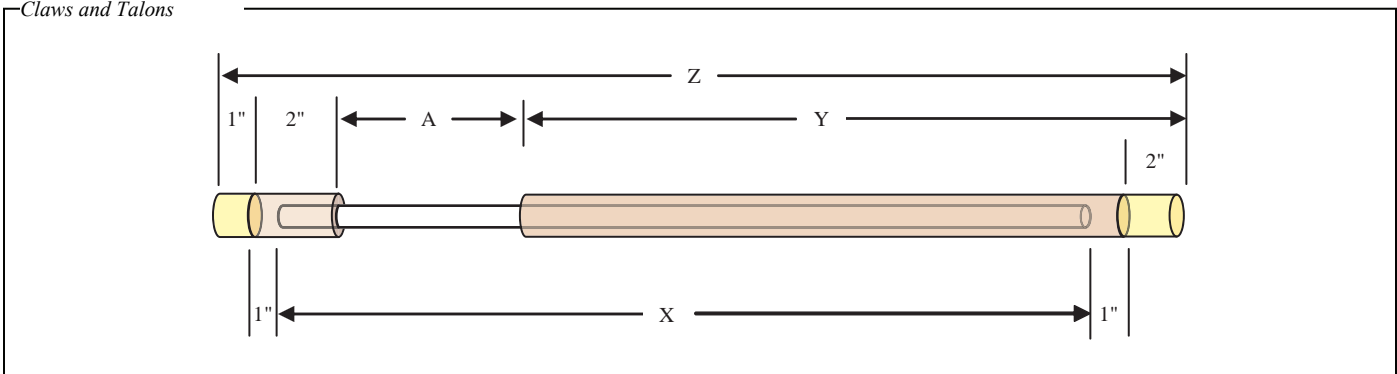

*Daggers, Long Swords and Bastard Swords**Claws and Talons***Making Daggers, Claws, Long Swords and Bastard Swords****Getting Started**

- The first step is to cut the pipe to the desired length and remove any burrs or chips from the ends of the pipe with a file or sandpaper. You want the ends to be slightly beveled to insure it does not cut through the foam. To determine what the length of the pipe is (X), you need to first determine the overall length of the weapon (Z). Then, using the formula below you can determine the pipe length:

$$\text{Pipe Length (X), inches} = Z - 5$$

- Next, tape the ends of the pipe over with two layers of duct tape, so the pipe will not cut into the foam and the foam cannot slip into the pipe.
- Next place a mark 1 inch from handle end and another mark at the length of your handle (A). If you plan on putting on a cross guard, you need to take that into account later.

**Making a Cross Guard**

A cross guard can be made from the same 5/8-inch foam from which the blade is made or other foam material, but you cannot use pipe to make the cross guard: It is not necessary to have a cross guard and you do not put a cross guard on a claw.

- Cut a piece of foam to the desired length of the cross guard, eight inches will do. You can cut a wedge out of the foam to make it smaller.
- Cut a hole in the center of the foam tube so that the pipe of the handle may be inserted through its center, forming a "T" with the blade. The hole

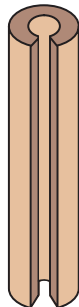

should go through the seam so when you put the cross guard on, the seam points towards the handle. Be careful not to make the hole too big, or it will weaken the cross guard.

- Secure the cross guard in place with the bottom of the cross guard even with your second mark (A). Use a couple of strips of strapping tape connecting the cross guard to the handle. It is very important to secure the top and bottom of the cross guard well. This will ensure when you are done the foam does not move off the pipe.

**Making the Blade**

- The pipe foam length is determined by taking the blade length (Y) and using the following formula:

$$\text{Pipe Foam Length, inches} = Y - 2$$

Or, conversely, you can measure the pipe from the cross guard to the end of the pipe and add 1 inch. To be safe you can make the foam a little longer and after taping down the blade, you can measure and trim the end, **but it is very important to make sure there is 1 inch of foam hanging over the end of the pipe.** Over time, the foam will move and if you make the foam come too close to the end of the pipe, it may poke through the end and will fail inspection.

- Next, test your foam on the pipe, if it is loose you will need to trim down the foam in the same way you did with the cross guard, cutting a wedge out at the seam. Either way, you must use strapping tape to secure the seam. This will insure your foam will not split, a very common reason for the weapon to fail. Put short, about 3 inch long strips over the seam. You want the fibers in the

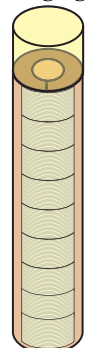

tape to be perpendicular to the seam.

- Make sure you remembered to tape the ends of the pipe with duct tape. Then, slide the foam down the pipe to either the cross guard or the mark you made for the end of the handle/beginning of the blade. Make sure the foam extends 1 inch beyond the end of the pipe. Make sure the seam is not on the striking surface of the weapon, this is not possible to ensure with claws or swords without cross guards, but if you have a cross guard place the seam so it is on the top not the sides of the blade. This will make the weapon last longer.
- Next, using strapping tape, secure the blade to the cross guard or to the pipe. One or two layers should be good enough, but make sure all areas of the foam are secured.
- Use some scrap closed cell pipe foam to fill in the end of the blade. You want to stuff it pretty good. There will be a lot of stress here and foam will wear out, so do not be afraid to stuff it tight. However do not stuff it so full that the foam bulges out of the top; a small bump is fine. Then cover the top with some strapping tape or duct tape, two pieces over the hole should do.
- Now you need to cut out the thrusting tip using the open cell foam. Trace the top of the blade onto the foam. Cut the foam out a little larger than your circle. Then trim it round, it does not have to be perfect, but close. The end result should be a 2 inch long cylinder just a little bigger than the pipe foam.
- Next, secure the tip to the pipe foam using duct tape. You need to slightly compress the foam to make it round, and you want to make sure you overlap the duct tape. If you cut your duct tape in 5 inch strips and over hang the top by about 1 inch you should get good coverage. Make two cuts into the duct tape that hang over the thrusting tip and fold down the flaps onto the thrusting tip. When you are done, the entire tip should be covered with duct tape.
- Next, you need to cover your weapon with duct tape. You need to plan this part out. You want to make sure you do not put too many layers of tape or your weapon will be heavy. Duct tape the cross guard first, then the blade. To make the weapon look nicer, put your duct tape on the sides of the blade first, then the top and bottom.

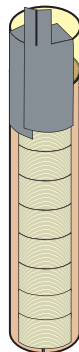

- Tape the thrusting tip just like you did with the other end, but this time, make sure you overlap both the open cell foam tip and the pipe to help secure the pommel to the pipe.
- Then cover the tape with whatever color you wish. You will have at this point two layers of tape over the end. This is okay and will strengthen your pommel.

#### The finishing touches...

- Poke several holes in the thrusting tip on both ends with a pin or needle so the foam compresses easily. The tip should compress to about  $1/3^{\text{rd}}$  its original height and spring back quickly.
- The handle needs to be finished. You should grasp your weapon and test the size. You do not want your finger tips to touch the palm of your hand. You can use duct tape to fatten up the handle or placing closed cell foam on the handle also works. You can finish off with duct tape, but cloth lace wrapping, gaffer tape, or hockey stick tape works well to keep the weapon's handle from being slippery.
- Lastly, add any decorations you wish to put on the weapon to finish it off. If you are going to use plastic gems, paint, cloth, or any other material, make sure you do not harden the striking surfaces or put any hard bits on any area that you might hit someone with normally. You cannot put sharp or protruding objects on your weapon.
- It is a good idea to write your name in indelible marker somewhere on your weapon. This is not required, but if the weapon card is lost and your name is on it, it can still be returned to you.

Your weapon is now (hopefully) ready for presentation to the Arms Marshal. Do not be surprised if your first weapon does not pass inspection; it takes practice to learn how to make a safe weapon.

#### The Handle and the Pommel

To create a safe pommel (butt end) for your weapon:

- Cut at least a 2-inch length of  $5/8$ -inch foam, but no longer than 3-inches. This will be your pommel.
- Trim the foam if you need to. Either way, use strapping tape to close the seam. Make sure you tape the end of the pipe with tape. Slide the pipe foam over the end of the pipe, tape it down with strapping tape and stuff the end with scrap foam, ultimately covering the end with strapping tape or duct tape as you did with making the blade.
- Next, make a thrusting tip for your pommel just like you did for the blade, except this time it needs only be a 1 inch long cylinder.

## Staves and Pole Arms

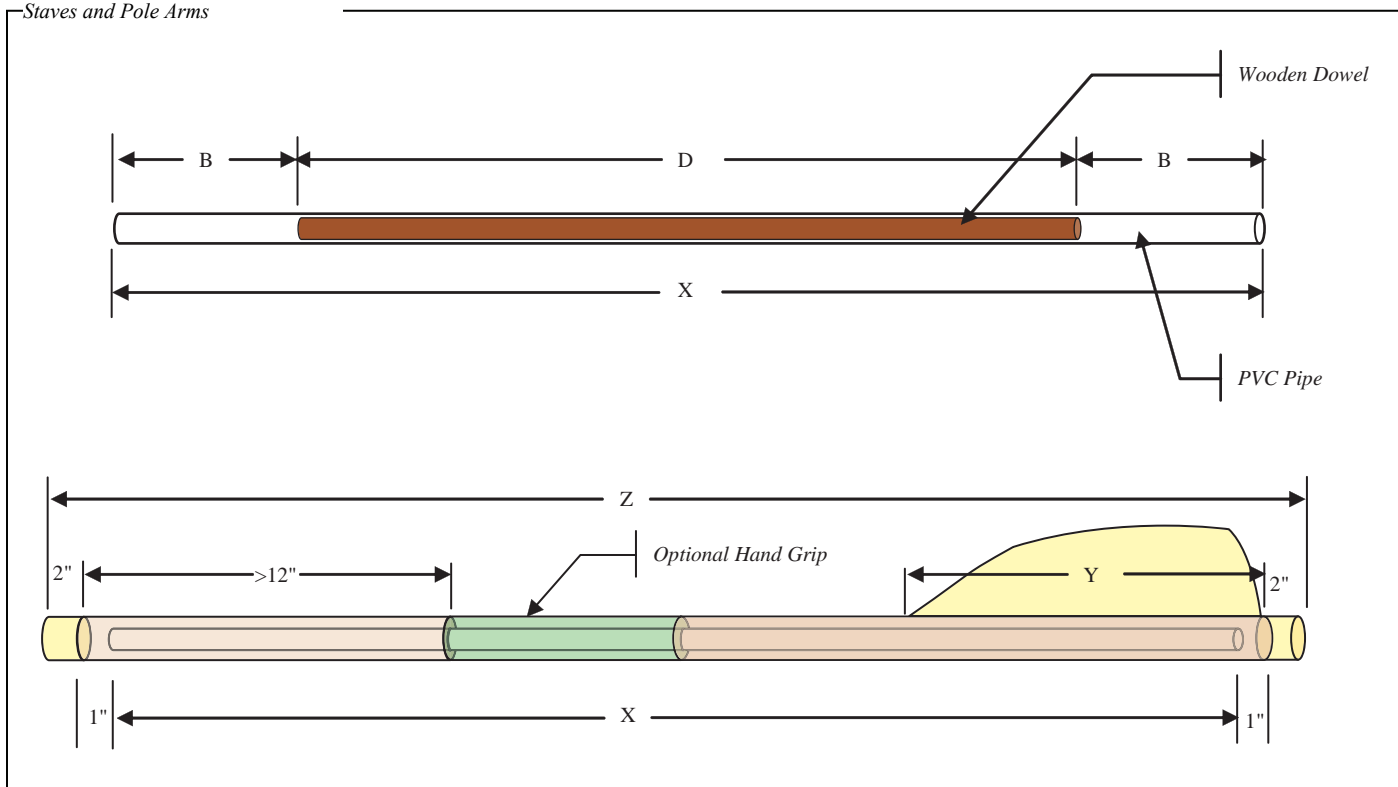
**Making Staves and Pole Arms**

The basic construction techniques for making these weapons are the same as making claws, daggers and swords. You need to cut the pipe using the same formula, use a file to bevel the ends, cover them with duct tape.

There are a few new things to consider when making these larger weapons. First, weapons over 50 inches tend to get whippy and whippy weapons will not pass weapons check, therefore only  $\frac{3}{4}$ -inch PVC or  $\frac{1}{2}$ -inch PVC or  $\frac{3}{4}$ -inch CPVC with a dowel can be used in their construction. Also, you need to decide how you will use your polearm. If you want to strike with the butt end, and you want to make a handle – an area of the weapon that does not have foam on it – you need to make sure the butt end is covered with enough foam. Also, both ends of the weapon need to have a 2-inch thrusting tip.

The biggest care you need to take with these weapons is the dowel. Depending on the length you will most likely need a wooden dowel. You should purchase the dowel to fit snugly into the pipe. You may need to shave the dowel down in order for it to fit correctly. Also, you need to put the dowel in the middle of the weapon. Following are the rules for making pole arms and staves.

**Getting started**

- Measure out how long you want your weapon to be (Z). Then cut the PVC pipe to this length (X), sanding or filing down the ends to a slight bevel. The length of the PVC pipe is given by this formula:

$$\text{Pipe Length (X), inches} = Z - 6$$

- Next you need to cut your dowel to length. The length of the dowel (D) is given by this formula:

$$\text{Dowel Length (D), inches} = X \div 2$$

- Now you must insert the dowel, shaving it down slightly to fit. You should be able to slide the dowel in with out forcing or hammering it in. You need to center the dowel in the pipe. To determine how far the dowel should be from an end (B), you can use this formula:

$$\text{Length from End (B), inches} = (X - D) \div 2$$

After you insert the dowel you should double check both ends to make sure it is centered.

- Now you need to secure the dowel in place by using a finishing nail about 1-inch long. Hammer the nail in about 3-inches from the end of the dowel, leaving a little sticking out both ends. Next cut both ends of the nail flush with the PVC pipe. Take your file and smooth out the nail so you cannot feel it when you run your finger over it. Lastly, take a piece of duct tape and wrap it once or twice over the area.
- Now you need to secure the other end. Rotate your pipe 90 degrees along the long axis and repeat the step above with another nail. You should double check your work and make sure the dowel is centered.
- Using duct tape, cover both ends of the pipe with two small pieces of tape.

**Adding the Pipe Foam**

- If you do not plan on having a handle for your weapon, simply take two pieces of pipe foam and put it over your weapon, leaving 1-inch of foam at both ends hanging over the pipe. You should put one piece on first, tape it down with several pieces of strapping tape then add the second piece of foam taping it to the first with several pieces of strapping tape.

- If you plan on having a handle on your weapon, you need to cut two pieces of pipe foam. Figure out how large a handle you want and where you want it. Then make sure there is 12-inches of pipe foam from the end of your handle to the butt end of the weapon. These 12-inches do not include the extra 2-inches of open cell foam for the thrusting tip.

You can make a pole arm with only 4 inches of foam at the end – the same way you would make a sword – but then you may **NEVER** use that end to attack someone.

- Now you should finish the ends of the weapon by filling the ends with pipe foam scraps, covering the end with duct tape, and making two 2 inch thrusting tips out of open cell foam just like you would with a sword. Tape the tips down with duct tape, just like with a sword.
- You should have something that looks like a staff, and in fact if you are making a staff, you can skip ahead to **Finishing Up** below.

### Making the Business End

- The bladed end of the pole arm is made out of open cell foam. You should trace out the pattern for the head of your weapon. Since the weapon is already padded, there is one rule as to how much extra padding you need. The length of the bladed end (Y) is fixed and must be followed. When cutting out the foam, it may help you to use an electric knife which cuts the foam very easily.
- After shaping the bladed end, attach it to the weapon with strapping tape, which tends to be stickier than duct tape. Also using some glue to secure the blade to the pipe foam is okay, just make sure not use a glue that will melt or dissolve either types of foam. Many super glues and hot glues will do this.
- Next, take duct tape and completely cover the open cell foam blade, overlapping the pipe foam to make sure the blade is secure.

### Finishing Up

- Cover the weapon from top to bottom in duct tape, much in the same way as the sword instructions above. Be sure to overlap the tape and cover all surfaces with the duct tape.
- Poke several holes in the thrusting tip on both ends with a pin or needle so the foam compresses easily. The tip should compress to about 1/3<sup>rd</sup> its original height and spring back quickly. Also, poke several holes in the blade if you have one.
- If there is a handle it needs to be finished. You should grasp your weapon and test the size. You do not want your finger tips to touch the palm of your hand. You can use duct tape to fatten up the handle or by placing closed cell foam on the handle also works. You can finish off with duct tape, but cloth or lace wrapping, gaffer tape, or hockey stick tape works well to keep the weapon's handle from being slippery.
- Lastly, add any decorations you wish to put on the weapon to finish it off. If you are going to use plastic gems, paint, cloth, or any other material make sure you do not harden the striking surfaces or put any hard bits on any area that

you might hit someone with normally. You cannot put sharp or protruding objects on your weapon.

- It is a good idea to write your name in indelible marker somewhere on your weapon. This is not required, but if the weapon card is lost and your name is on it, it can still be returned to you.

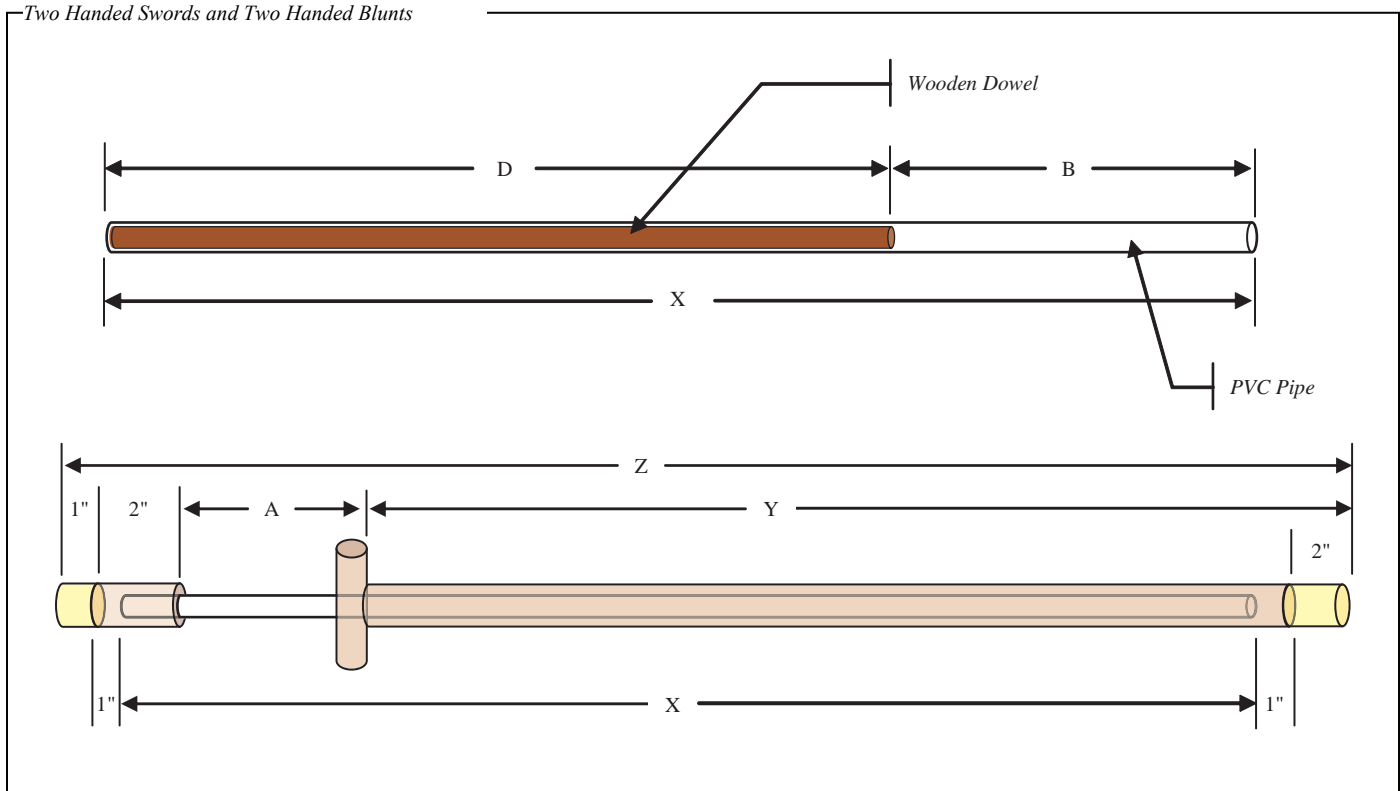

## Two Handed Swords and Two Handed Blunts

**Making Two Handed Swords and Blunts**

By now you have been exposed to many different construction techniques. Two handed swords and two handed blunts incorporate the methods used to make swords and pole arms. The instructions for these weapons are listed only in an outline, for more detail look to the instructions for making swords and pole arms.

- Start with the pipe, cut it to length, bevel file the ends, and tape them up.
- If you are using pipe that requires a dowel you can use the formula below to determine the length:

$$\text{Dowel Length (D), inches} = X \div 3$$

Use the same procedure with the finishing nails, rotating the pipe 90 degrees. The end of the dowel should line up with the end of the pipe.

- Mark out the handle.
- Make the cross guard, if you wish one, and attach it to the pipe.
- Cut the pipe foam, use strapping tape to close up the seam and slide it onto the pipe, taping the foam to the cross guard or pipe.
- Fill in the tip, tape it over, and attach a 2 inch thrusting tip.
- Make the butt end, use strapping tape to secure it closed and to the pipe, fill the butt end, attach the 1 inch thrusting tip.
- If you are making a blunt weapon, cut the open cell foam out, shape it and attach it to the pipe foam.
- Cover the weapon with tape.

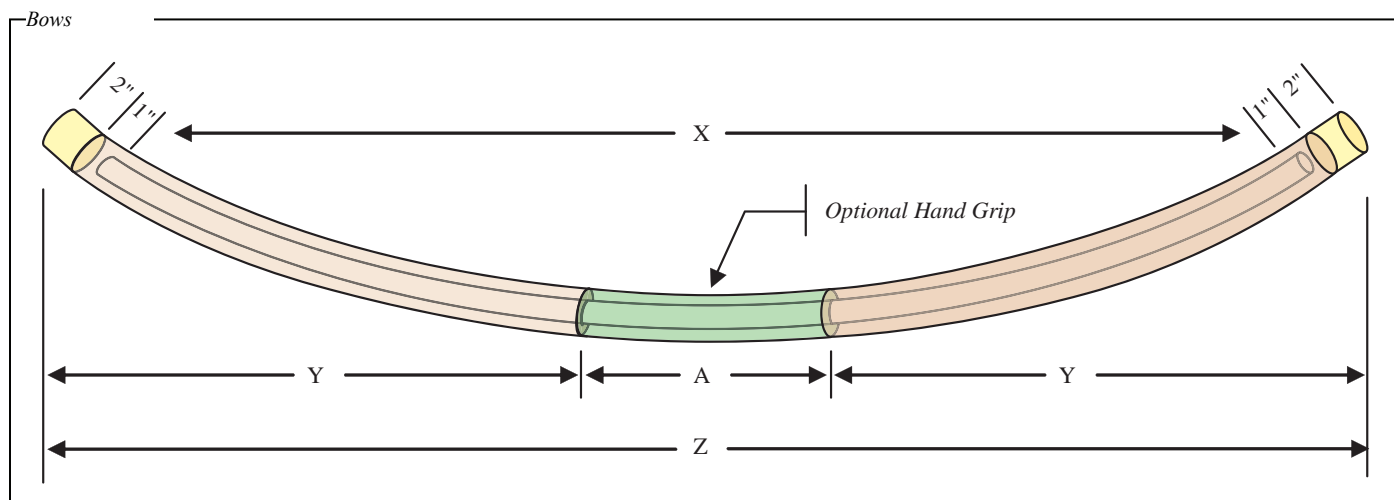

### Making Bows

The most difficult part of making a bow is bending the PVC pipe. PVC has a low melting temperature and can be softened with boiling water or direct flame.



**WARNING!!** Care should be taken when heating PVC with fire! It is combustible and you are liable to set it on fire when using an open flame if you are not careful.

Care should also be taken to heat and cool the PVC as few times as possible. PVC tends to get more brittle when heating.

- Start with the pipe, cut it to length and bevel file the ends. Do not tape the ends at this point.
- Next prepare a flat hard surface with markings for the general shape you want the bow to have.
- Heat the PVC until it just starts to deform. Place it on the floor and gently bend the PVC into the desired shape.
- Take care not to flatten any point of the PVC.
- Let the PVC cool completely before moving onto the next step.
- From here the construction is similar to other weapons.

Some things to note:

- The max length listed on page 210 is equal to Z in the diagram above and is measured from tip to tip, not over the length of the PVC pipe. You need to take this into account when cutting the PVC pipe before you bend it.
- When measuring the length of the pipe foam, make sure you measure on the outside of the pipe and add some more. How much more depends on the length of pipe. When you put the pipe foam on the pipe it will be shorter than you expect.

To make the string of the bow, use a length of elastic. Attach both ends to the ends of the bow to the pipe foam with duct tape. Do not stretch the elastic, it should have most of its stretchiness left to allow for expansion in combat.

## How Not to Make a Weapon

The following may not be used under any circumstances in weapon construction.

- Steel, aluminum, copper or any other metal. Metal has little or no ability to absorb shock or to flex. If you accidentally hit someone on the head or another vulnerable part of the body, serious injury could occur. Do not use a metal core inside the PVC pipe; if the weapon breaks during combat, you will have a sharp splinter of metal sticking through the foam.
- Foil, metal, or stiff plastic tapes. These can cause serious cuts.
- Other plastics or fiberglass. These materials will chip and splinter when subjected to the repeated stress of combat and can lead to injury. Wooden dowels can only be used to reinforce weapons.

LAIRE is serious about these rules. Any attempt to conceal these materials in the construction of a weapon will be found and disciplinary action will be taken. Violate these rules, and someone will get hurt.

These basic precepts are the most important ones in LAIRE weapon construction:

- No hard ends or edges may protrude from the weapon.
- All surfaces that could come in contact with another player must be padded.
- No illegal materials will be tolerated in overall weapon construction.
- No sharp foam points, with or without duct tape over them, are allowed.
- No lanyards are allowed. You cannot attach your weapon to your person by any means out-of-game ever.

## Notes on Weapon Construction

Bring extra construction materials to each event. If your weapon fails inspection for any reason, it may be possible to make repairs at the event.

### *PVC and Pipe Insulation*

We have found that though it is slightly harder to slide foam over PVC than CPVC, PVC is a thicker and stiffer pipe to work with. Be sure to check the exterior diameter of your tubing with the interior diameter of the insulating foam you buy. Foam is sold to fit different sizes of pipe, and nothing is more frustrating than getting home only to discover your foam is too large to fit snugly, or too small to fit over the pipe at all.

### *The Tips of Weapons*

Thrusting tips should be no less than 1-inch high (compacted) and no more than 2-1/2-inches high. Tips that are too large are easily broken or torn, and excessively compacted ones are too hard for safe play. Try not to lean on your weapon when it is point down, as this degrades and compacts the tip.

Keep an eye on the striking surfaces of your weapon, as foam will decay and break down over time. When it starts to feel too soft or you can easily feel pipe, it is time to rebuild your weapon.

### *Long Weapons*

Weapons over 3-feet long should be constructed of 3/4 inch CPVC tubing, or 1/2 inch or larger PVC tubing, and possibly with reinforcement pipe as well. If a weapon is too “whippy” or flexible, it will not be approved.

Pole arms must be padded at least 15 inches below the bottom of the striking surface, or padded over their entire length if you are going to strike with the butt end of the weapon.

Javelins and thrown weapons, such as throwing daggers, must be constructed entirely of foam. They may not contain any PVC. Spears are not throwing weapons in this game.

Wooden dowels can be used to stiffen long weapons, but only when encased in PVC or CPVC tubing. This is an advanced weapon construction technique, and you should check with an Arms Marshal before you attempt it. A general guideline is that the dowel should fit snugly into the tube it reinforces, or be taped along its length to make sure it does not rattle.

### *Special Weapons*

No weapon may be used that can trap or hook a player’s weapon or body. “Trapping” does not include pinning a weapon with another weapon while outdoors. No weapon can have sections connected by rope, chain, or cord (nunchucks, flails, whips, etc.). A weapon *cannot* be attached to your wrist by a lanyard. This is to prevent entanglements and possible injury.

Weapons entirely covered with white duct tape are assumed to be the “claws” of a monster in-game. Under no circumstances may player characters wield a claw without the appropriate skill or express permission of a Plot Marshal.

If you are planning to make an unusual weapon, it is a good idea to make a sketch and show it to an Arms Marshal before you begin construction.

## Weapon Care

When storing your weapon, you should lay the weapon down flat. This will greatly extend the life of your weapon.

Weather can greatly shorten the life of a weapon. If your weapon gets wet, be sure to allow the weapon to dry out fully. The tape used in constructing your weapon may peel off when wet. The open cell foam used on the tips will retain water and rot or grow moldy if not dried out. The closed cell pipe foam will also break down if left wet for long periods of time.

During cold Events, the closed cell foam and tape tends to get harder, be careful of your swings during these Events. Tapes used in construction of a weapon may become brittle or the glue can lose its adhesiveness in cold weather. Do not store your weapon in the cold for long periods of time. Also, during snowy Events, take care to not leave your weapon in the snow for a long time.

Heat, hot weather and high humidity can be particularly devastating to the materials used to construct your weapon. Do not leave your weapon in a car or near a heater. The glues will dry out, the foam will melt, and the tape will crack and peel.

Shields

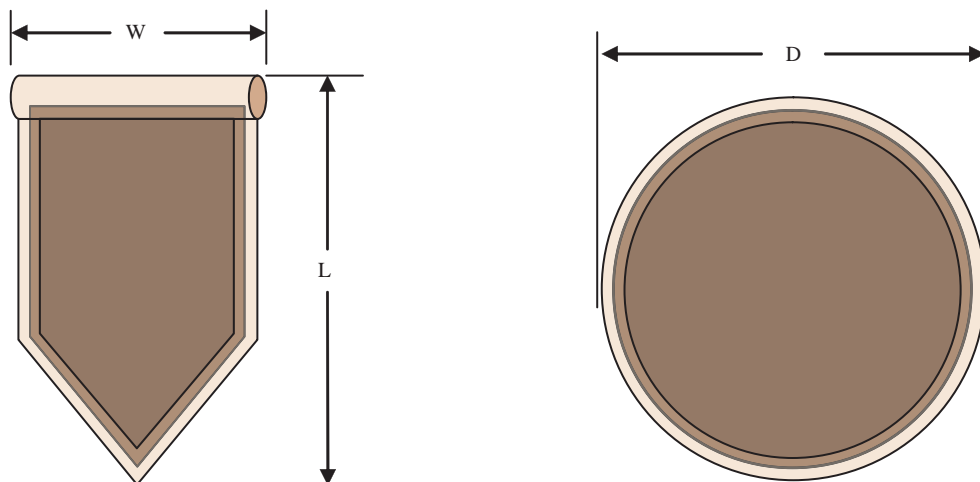

## Making a Shield

Shields can be made of either wood, plastic or cardboard. Plywood with a 1/4-inch thickness works well, too much thicker and the shield gets too heavy and becomes uncomfortable, but is not illegal. You can go up to 3/8-inch or 1/2-inch thick shield. Particleboard or plastic board, which is a wood and plastic composite material, is also acceptable. Hard woods such as oak or pine tend to be too heavy for their thickness and should be avoided. Plastic snow boards cut down to size or other pre-fabricated plastics are also acceptable. Several layers of a corrugated cardboard called tri-board works very well and is light. Use a strong glue such as Gorilla Glue or Elmer's Wood Glue to hold the layers together.

Round shields are the easiest to size, but difficult to cut perfectly round. To determine the correct size use the formula below:

$$\text{Shield Diameter (D), inches} = 2 \times \sqrt{(\text{Area} \div \pi)}$$

For square shields (not depicted in the diagram above) the following equation is easily used to determine the width based on the area and max length:

$$\text{Shield Width (W), inches} = A \div L$$

For shields of non-regular shapes, such as depicted above or with curved edges, take the maximum width and maximum length and verify the area using the formula for the area of a square. While the shield will have less area than a square shield, the advantages of less weight and the fact that the shield will still protect as effectively makes the calculation the same:

$$\text{Shield Area, inches} = L \times W$$

### Putting on the Handles

The next step is to add the handle and forearm strap. You can use any material you wish to do this, even an actual handle from the hardware store. Leather or canvas straps work well also. You can bolt the handles to the shield, but make sure you put the head of the bolt or screw on the outside the shield. Tape up the end of the bolt or use an acorn nut to cover the exposed bolt.

If you are using leather or canvas to make your straps, you can cut slits in the shield and loop the straps through the shield and sew the loop closed.

Where exactly you place the handle and forearm strap is up to you, what ever feels comfortable for you to hold. There is no rule for this.

### Putting the Foam on the Edges

After you have the shield cut out, you should tape the edges of the shield to make sure it will not cut through the foam. Cut the corners off the shield first and add extra tape to pad the corners well.

If you are using wood and plan on painting your shield, you should do it now. Duct tape will stick to paint better than wood. Next, use duct tape to tape down the closed cell pipe foam to the shield. You could use a strong glue like Gorilla glue to tack down the foam if you wish; this will help to make the shield last longer. You should still tape down the foam with duct tape.

If you are not painting your shield or if you are using cardboard, you will need to tape the surface of your shield. When using cardboard, be careful to overlap the duct tape well, this will prevent water from getting your shield wet.

### Finishing Touches

You can put extra foam bits on your shield to give it more flair. You should use open cell foam for this. Remember safety when you do this. Pointy foam shapes are disallowed, even in the construction of a shield.

Make sure you do not have anything sticking out from the shield, such as spikes of any kind. You cannot bash with a shield and having pointed things protruding from your shield is a safety hazard.



## Weapon and Shield Size Requirements

All weapons in the LAIRE system have minimum and maximum size requirements. Weapons that do not fall between these limits will not be allowed into the game. All measurements are given in inches.

Weapon	Grip	Total Length		Padded Length		Blade Length		Weapon Damage
		Min	Max	Min	Max	Min	Max	
One Hand Sword	5 ± 1	26	44	-	-	18	36	2
One Hand Blunt†	5 ± 1	26	44	18	36	6	20	2
Two Hand Sword	10 ± 2	50	62	-	-	40	48	3
Two Hand Blunt†	10 ± 2	50	62	40	48	12	36	3
Bastard Sword	8 ± 2	45	50	-	-	36	40	3/2*
Bastard Blunt†	8 ± 2	45	50	36	40	8	24	3/2*
Small Weapon	5 ± 1	15	24	-	-	8	17	1
Quarterstaff	16 ± 8	60	72	-	-	-	-	2
Polearm/Pole Axe	16 ± 8	60	72	60	72	12	24	4/2
Spear	16 ± 8	48	72	8	16			3/2*
Thrown Weapon	-	6	12	6	12	6	6	1
Javelin	-	36	36	36	36	2	3	2
Bows	8 ± 2	36	60	-	-	-	-	3
Crossbows	<i>Special</i>	24	36			12‡	24‡	4
Claws**	5 ± 1	21	23	-	-	14	16	1
Talons††	5 ± 1	25	27			17	19	1

\* The first number is used when striking with two hands, the second when using only one.

† For blunt weapons, the blade length indicates the padded area of the weapon. The player may add an extra padded area, such as the head of a mace that may be any size, so long as it conforms to the blade length. For clubs, the player may make the entire blade length padded, making the weapon look like a club.

‡ Blade length here refers to bow length. The bow length cannot be longer than the total length and no less than half the total length.

\*\* Claws have no cross guards and are all white. The handle maybe any color.

†† Talons have no cross guards, are all white, and have a ¾" to 1" black stripe down the full length of the blade down opposite sides.

Shield	Overall Area		Length*		Diameter	
	Min	Max	Min	Max	Min	Max
Shield	144 in <sup>2</sup>	1296 in <sup>2</sup>	20 in	48 in	14 in	41 in

\* The maximum length for shield is also dependant upon the player using the shield. For Medium Shields, it is the top of the shoulder to the waist. For Large Shields, it is the top of the shoulder to the knee.

Note: The width of a shield must be less than or equal to the length.

### Approving Weapons

Weapons can wear out, so even if a weapon is legal at one event it may no longer be legal at the following event. Therefore, at each event you must present all the weapons that you bring to an Arms Marshal for inspection.

### The Weapon Card

Every weapon must have a Weapon Card. This card lists your name, the type of weapon, and the date of the Event for which the weapon was created and approved. Without a dated weapon card, a weapon does not exist in-game. If you lose the Weapon Card, then you have lost the weapon in-game. The Weapon Card must be attached to the weapon physical representation at all times. Clear tape can be used to attach the Weapon Card.

You may have any number of Weapon Cards in your sleeping area. However, you must have a physical representation for each card you take out with you.

At the beginning of every Event, you must get all your weapons approved by an Arms Marshal. If your weapon is approved, the

Arms Marshal will issue you a colored dot with the Event date (month and year). Their initials and Player Number.

As you play the game, your character may acquire special weapons or shields: silver, Mithril, or magical, for example. If you have one of these special weapons, you will be issued a special Weapon Card along with a physical representation of the weapon or shield. These weapons are property of LAIRE.

### The Weapon Inspection

This is what an Arms Marshal will do when they inspect your weapon. If you "pre-inspect" your own weapon, you can spot problems and fix them before the formal inspection.

The Arms Marshal will look over the weapon for any obvious illegal weapon construction techniques. Some of the obvious reasons to reject a weapon are:

- Duct tape that has been spiral-wrapped over a striking surface.
- The weapon is too long or too short for the type of weapon it is supposed to represent.
- The weapon is too heavy, which is a good sign that metal was used in its construction.
- Foam protruding from underneath duct tape. Foam can rip, taking duct tape with it.
- Decorations or points of foam sticking out of the weapon. If it can get into someone's eye socket, the weapon will be rejected.

Next, the Arms Marshal will squeeze all the potential striking surfaces of the weapon. There must be at least 5/8<sup>th</sup>-foam over every

striking surface. The weapon will be rejected if the foam feels too thin, cracked, or the PVC pipe can be felt through the foam.

The Arms Marshal will inspect any thrusting tip on the weapon. On spears and pole arms, they will inspect the haft end of the weapon as well. They will squeeze the tip to make sure it is thick enough and soft enough not to injure a player. The Marshal will also check if the tip is too soft; if it is, it might rip off. The Marshal will dig their fingers into the tip from the top and from the sides, including the boundary between the open-cell foam and the pipe insulation, trying to feel the PVC pipe; if they can feel it, the weapon will be rejected.

The Arms Marshal will tug on any protruding parts of the weapon. If it cannot stand up to a simple tug, it will not stand up in combat.

If your weapon can pass all these tests, it will probably be approved. However, be aware that an Arms Marshal has considerable discretion in rejecting a weapon; they are trained to err on the side of safety.

## Armor

While the weapons in LAIRE are made out of foam, we encourage players to wear real or real-looking armor. A good suit of armor can add a lot to the medieval look of the game. The defensive value of a character's armor is represented in the game by Armor Points. The Armor Point value of the armor that you wear is assigned by an Arms Marshal.

## Types of Armor

There are seven types of armor that may be worn by a player. Any type of armor worn by a player other than these types will be assigned to one of these standard categories by the Arms Marshal. The armor types are:

Armor Type	Description
Costume (C)	Medieval and fantasy clothing. This is worth 2 Armor Points. The character receives 1 more Armor Point for appropriate costume footwear.
Soft Leather (SL)	Real leather is 1/8" thick without studs.
Rigid Leather (RL)	Real leather more than 1/8 thick. Or, soft leather with metal studs no more than 2" apart, measured from the center, with each stud having a diameter between 1/2" to 1". Or, leather scale mail armor with each scale being no larger than 6" square and more than 1/8" thick. Two layers of soft leather sewn or riveted together counts as rigid leather. Wearing two separate layers of soft leather does not count.
Ring Mail (RM)	Metal rings with an inner diameter of not more than 1" and an outer diameter of 3" mounted onto soft leather or better. Or, rigid leather with metal studs no more than 2" apart, measured from the center, with each stud having a diameter between 1/2" to 1".
Chain Mail (CM)	Metal rings with an inner diameter of at least 3/8" and no more than 5/8" diameter (4-and-1 chain weave, more dense weaves acceptable).
Light Plate (LP)	Metal with a thickness of 20 to 22 gauge.
Heavy Plate (HP)	Metal with a thickness of 18 gauge or more. <b>Plate armor made of any material other than steel, regardless of thickness, can never be heavy plate.</b>

## Armor Point Table

Armor Location	SL	RL	RM	CM	LP	HP
Helmet, Full	1.3	2.5	3.8	5	6.3	7.5
Helmet, Partial	0.6	1.3	1.9	2.5	3.1	3.8
Helmet, Cap	0.3	0.6	0.9	1.3	1.6	1.9
Neck	0.3	0.6	0.9	1.3	1.6	1.9
Shoulders *	0.6	1.3	1.9	2.5	3.1	3.8
Breast Plate	1.3	2.5	3.8	5	6.3	7.5
Back Plate	1.3	2.5	3.8	5	6.3	7.5
Upper Arms *	0.6	1.3	1.9	2.5	3.1	3.8
Elbows *	0.3	0.6	0.9	1.3	1.6	1.9
Lower Arms *	0.6	1.3	1.9	2.5	3.1	3.8
Groin	1.3	2.5	3.8	5	6.3	7.5
Upper Legs *	0.6	1.3	1.9	2.5	3.1	3.8
Knees *	0.3	0.6	0.9	1.3	1.6	1.9
Lower Legs *	0.6	1.3	1.9	2.5	3.1	3.8

\* Indicates that points should be halved if only one is worn; i.e., only one sleeve, or only one knee is covered.

## Assigning Armor Points

The Armor Point system used at LAIRE allows the character to receive Armor Points for anything from a costume all the way up to real plate armor. If the point system seems complicated, do not

worry; a trained Arms Marshal will evaluate your armor and assign the number of Armor Points you will receive. Armor Points are awarded for two aspects of your armor:

### *The In-game Strength of the Armor*

The thicker and tougher the type of armor is, the more Armor Points it will receive. This reflects the in-game ability of the armor to protect a character. Points are given for each individual piece of armor by an Arms Marshal according to the Armor Point Table above. For example, if a character is wearing rigid leather armor that covers the front, back, and shoulders, the Arms Marshal would sum  $2.5 + 2.5 + 1.3 = 6.3$  Armor Points.

### *Real Armor Bonus*

The suit of armor will also receive more Armor Points for real armor than for a substitute. For example, the character will get more Armor Points for real leather armor than for a piece of studded naugahyde. This reflects the fact that real armor is heavier than “costume” armor, and so the players who bear the extra weight receive Armor Points in compensation and that real armor adds to the fantasy feel of the game and looks better.

The Real Armor Bonus is partly subjective on the part of the Arms Marshal; the Marshal judges how realistic the armor looks and whether it would protect the character in real combat. The bonus listed in the below table determines what the Arms Marshal will use for the Real Armor Bonus.

Class	Penalty	Description	Example
Real	0%	Real leather of the correct thickness. Real steel or iron metal armors.	Chain mail made with real metal and correct gauge and size. Studded leather made from real leather and metal studs.
Replica	25%	Plastic armor that looks real, Aluminum instead of steel	Scale mail made from plastic rain barrel riveted to ¼” leather
Imitation	50%	Armor that can easily be seen as fake, but still looks like armor.	Chain mail made with binder rings, painted hubcaps or garbage pail lids, chain mail links that are excessively small, naugahyde or “pleather”, plastic costume armor
Poor	80%	Costuming made to look like armor.	Cloth that looks like chain, toy armor, rubber armor, cardboard covered in aluminum foil, plastic rings sewn to pleather, sporting equipment* like football shoulder pads, hockey goalie masks

\* If the sports equipment has been modified so it is unrecognizable as sports equipment, then it can be considered Replica armor.

In the above example, if the armor was naugahyde leather scale armor that looks real, the Arms Marshal might award the Imitation penalty and suit of armor would be worth  $6.3 * 0.5 = 3.15$  Armor Points.

### *Rounding the Sum*

Finally, any fractional amount in the Armor Point total is rounded up to the nearest whole number. In the above example, the 3.15 Armor

Points would be rounded to 4.0; this would be the final Armor Point value of the armor in the example.

### *The Armor Card*

The Marshal will record each of these numbers on your Armor Card: the Armor Point value of each piece of your armor, and the Real Armor Bonus. The Armor Card is your permanent record of the value of your armor, and you should bring it to each LAIRE Event.

The Armor Card establishes that your character has that armor in-game. If you lose the Armor Card, then you have lost the armor; keep your card in a safe place. If your armor is lost in-game, then you must give up the Armor Card. If you do not recover your armor again in-game, you will have to go to the Armory, have your armor reevaluated, and pay a fee to purchase new armor.

If your armor is reevaluated, the new Armor Point value may be different from the old one. This is because the Real Armor Bonus is subjective, and may be awarded differently at different times.

If you add a new item to your armor, you must go to an Arms Marshal to have the new item indicated on your card. If you entirely replace your armor, you must visit the Arms Marshal to get a new Armor Card for the armor; you may also have to pay an in-game fee to bring the new armor into the game. You are allowed to have as many suits of armor as you like, as long as all the pieces of armor remain in-game.

### *Armor Point Tags*

When you first get your suit of armor you will be given an equal number of Armor Point tags equal to the number of Armor Points on your Armor Card. **These Armor Points do not reset in between Events and, when the armor is reduced to 0 Armor Points it must be repaired.**

When you take normal damage, the points of damage are first taken from your Armor Points. Only when all your Armor Points have been expended does your character take Body Point damage. When you lose Armor Points, you give the expended Armor Point tags to the player who caused the damage.

### *Resetting Armor after Combat*

The character’s armor is not used up entirely after each combat they get into. After the armor has taken enough damage to reduce it to 0 Armor Points, the character may spend 5 minutes in-game “resetting” the armor. The armor is reduced by 3 Armor Points every time the character resets the armor. For example, if a character has a suit of chain mail worth 12 AP and then gets into a fight that reduces the armor down to 0 AP, the character may spend 5 minutes resetting the armor. The armor now has 9 AP to protect the character in their next fight. The player should hand over the used Armor Point tags to the player they were involved in the combat with.

It is possible to walk away from a long fight and reset armor, but if the character is interrupted while doing so they do not have any armor available and must start again later from the beginning spending the full 5 minutes to reset the armor.

While resetting armor, the player should role-play their character adjusting and fixing the armor so it is obvious to everyone what they are doing.

If your armor is not reduced to 0 Armor Points but has been damaged, then resetting the armor will still degrade it by 3 Armor Points.

### *The Helmet and Waylay*

If your armor includes a helmet, the Arms Marshal will judge whether the helmet will protect you from a Waylay. You need to have a helmet that covers your head and the back of your neck to qualify for Waylay protection. The Arms Marshal will note the separate armor point value of your helmet on your armor card. In order for a Waylay to knock your character unconscious, the blow must do more damage than the number of Armor Points in your helmet.

For the purposes of Waylay, it is assumed that the Armor Points in your helmet are the last Armor Points expended. For example, assume you wear 10 Armor Points, including a helmet that is worth 1 Armor Point. If you are hit for 5 points of damage, you have 5 Armor Points remaining; your helmet is still worth 1 Armor Point. If you are then Waylaid with a blow of “Waylay one,” you are *not* knocked unconscious, you have 4 Armor Points left, and your helmet is still worth 1 Armor Point. If someone else then strikes you with “Waylay three,” you *are* knocked unconscious, you have 1 Armor Point left, and your helmet is still worth 1 Armor Point. However, if someone does one or more points of additional damage to your character, you will have no Armor Points left, and no helmet protection against a Waylay.

### *Armor Repair*

If your armor has been damaged, there are two ways to have it repaired during an Event. The first way is for a character with the Armor Smith skill to repair your armor. The second way is to go to the Armory, which will repair your damaged armor for an in-game fee. It is not possible to repair armor above the Armor Point maximum listed on your Armor Card.

A player with the Armor Smith skill receives a number of Armor Repair tags at the start of an Event. When their character repairs your armor, they will take the Armor Repair tags, sign their name on the back, and give you the expended tags to use as replacement Armor Point tags.

### **Armor Notes**

Only one type of armor may be worn at a time on each body part. A player may not “layer” chain mail and plate mail to receive the points of both. If armor of different types covers the same area of the body, then the higher point value armor takes precedence.

Gauntlets with sharp points, edges, or studs are forbidden. Any armor with sharp edges or points that might come into contact with other players is also forbidden. Do not include spikes or sharp armor, you are likely to injure someone or damage someone’s weapon.





## Making Packet Beanbags

Spells, and sometimes arrows, are represented by small beanbags filled with birdseed. This section shows you how to make them. Spell packets in LAIRE are always out-of-game. They cannot be stolen from you and do not exist in-game until you cast a spell.

### Spell Packet Construction Instructions

The following is instructions on how to make spell-packet beanbags. First, select your fabric. Choose brightly-colored cloth; remember that one day you will be searching for the beanbag in the middle of the night in the woods. Some people make their beanbags out of brown-and-black cloth, and these people have to replace their beanbags often. Since you need to stitch together two pieces of cloth, you may want to pick two different bright colors. **You cannot make a spell packet using white, red, or a combination of those colors, since these are the colors of the beanbags used by NPC's.** In addition, green is also disallowed, as this color indicates poisons or other throwable alchemy and brown, yellow or brown and yellow is for arrows. One square yard of fabric should make about 100 beanbags.

Cut the fabric into 2-1/2-inch wide strips. Stitch together the long edges of the cloth strips using heavy thread and small stitches. You should now have a long tube of cloth. Stitch across the tube every 2 3/4 to 3 inches, then cut the tube 1/4 inch under each seam. This will give you a small bag; turn the bag inside out to hide the stitches.

Now partially fill the bag with parakeet birdseed (the small kind, not the kind that has sunflower seeds). You will be disciplined if you use anything other than birdseed to fill your packets. Do not pack the bag so tightly so that the packet might hurt someone if it accidentally hits them in the face.

Alternately, you can use a sewing machine and sew the bags all at once. To the right is an illustration of both methods.

Once you fill the bag, stitch it closed. The final beanbag should fit snugly into a 35mm film canister. Do not make your packets too large; oversized spell packets will not be allowed in the game.

Spell packets will be inspected at Events to check that they adhere to the standards given above: filled with birdseed, not larger than a 35mm film canister. Some people may have spell packets available for sale at Events, but this is a purely voluntary effort on their part; LAIRE assumes no obligation to have spell packets available for the player's use.

### Arrow Packet Construction Instructions

The construction of an arrow packet is the same as a spell packet with one exception. Arrow packets are constructed with two 12-inch long tails made from ribbons. The ribbons and packet should be yellow, brown, or brown and yellow. Any combination is fine. **The tail ribbons for NPC arrow packets have to have one red and one white tail.**

When you lay out your cloth and are ready to sew the bottoms, place the ends of the ribbon across the stitch between the two layers of fabric. When you turn the packet out, the ribbon will be on the outside.

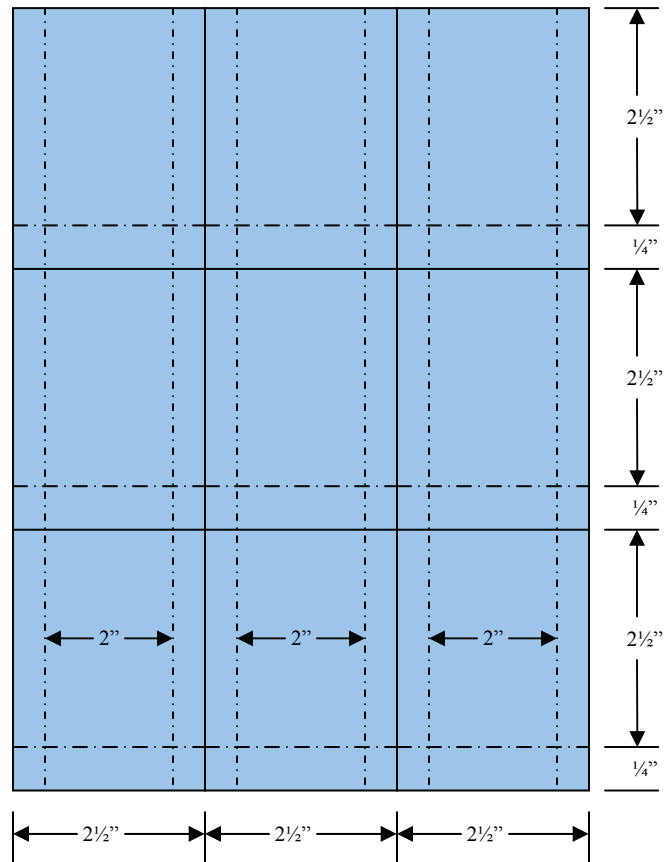
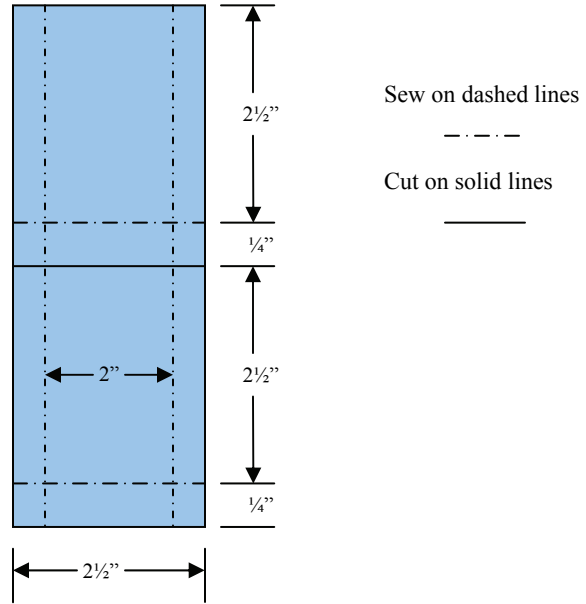









## Chapter 7: Playing the Game...

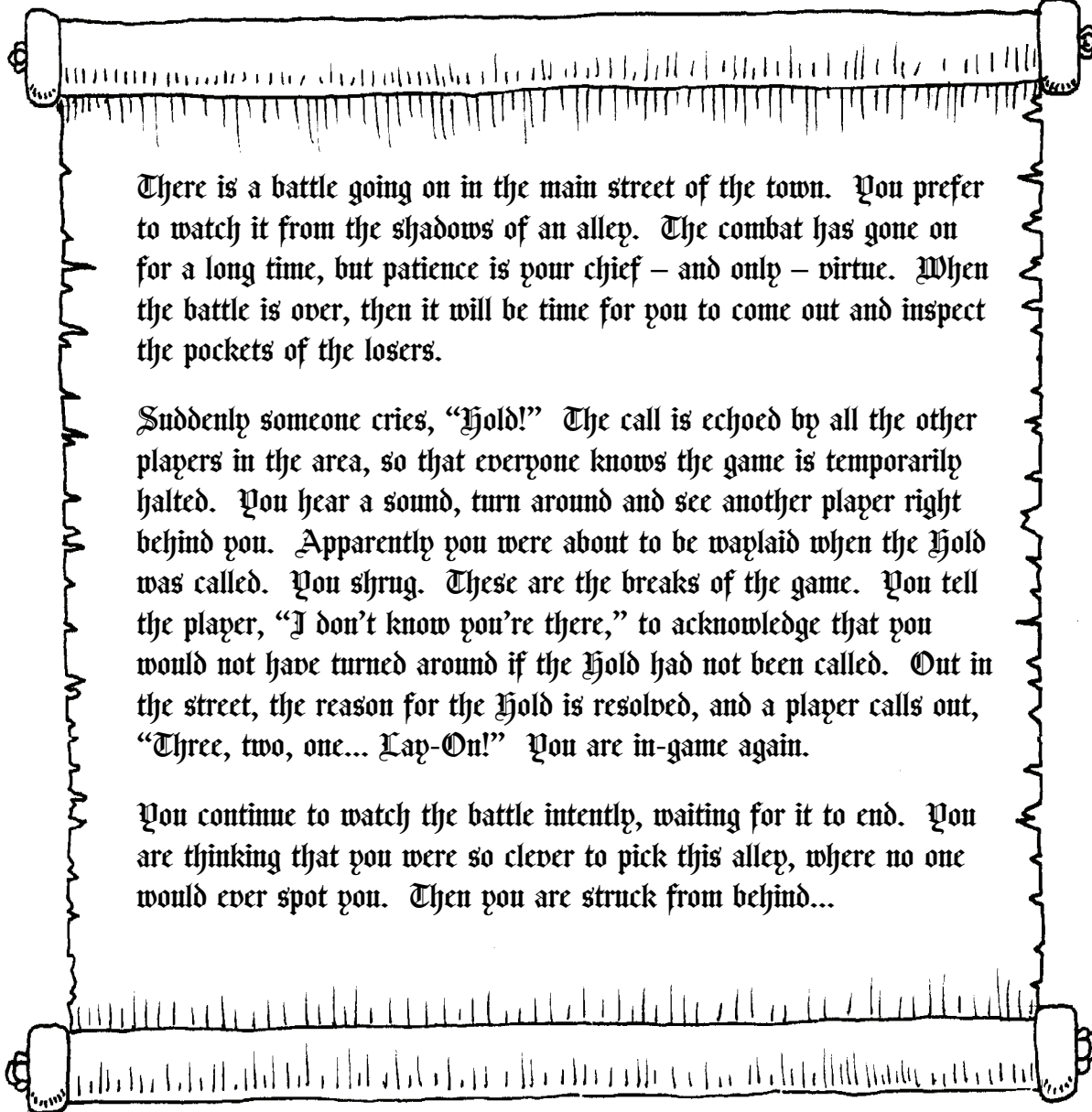

There is a battle going on in the main street of the town. You prefer to watch it from the shadows of an alley. The combat has gone on for a long time, but patience is your chief – and only – virtue. When the battle is over, then it will be time for you to come out and inspect the pockets of the losers.

Suddenly someone cries, “Hold!” The call is echoed by all the other players in the area, so that everyone knows the game is temporarily halted. You hear a sound, turn around and see another player right behind you. Apparently you were about to be waylaid when the Hold was called. You shrug. These are the breaks of the game. You tell the player, “I don’t know you’re there,” to acknowledge that you would not have turned around if the Hold had not been called. Out in the street, the reason for the Hold is resolved, and a player calls out, “Three, two, one... Lay-On!” You are in-game again.

You continue to watch the battle intently, waiting for it to end. You are thinking that you were so clever to pick this alley, where no one would ever spot you. Then you are struck from behind...



If you have read this rulebook from the beginning, at this point your head may be spinning from all the rules. Up to this point the rulebook has been about almost nothing but rules. If you have read them all, there are about 240 skills, 165 spells, 150 alchemical items, and 90 sorcery rituals; quite a lot to take in all at once.

But you may be asking yourself, “How do I play the game?” Hopefully this chapter will answer that question for you. The rules are simply a framework for the real heart of the game, the roleplaying. What you do at a LAIRE Event is act, react, and interact with the other players within the game world using the plot line as a backdrop of the story. In any fantasy book you read, the world is the stage and the characters are the players – what the book is really about. The world may be interesting, inventive and new, but what keeps you turning the page is the development and story surrounding the characters.

At LAIRE, you are the character in your own book. What you do or do not do writes the story of your character.

## Glossary of Common Game Terms

If you are new to LARPing or just new to this rulebook, this list of common game terms can help you understand the rules better.

**Advanced Career:** Refers to any of the ten Advanced Careers listed in Chapter 4.

**Armor Points:** A measure of the armor protection a character has. All types of Armor Points are stackable, but Armor Points from the same source are not. For example, a character can only have one *Armor* spell or receive the benefits of only one Oil of Armor.

There is an order that the character’s Armor Points are lost; different types of Armor Points are lost in the following descending order:

Type of Armor
<i>Armor</i> Spell
Magical Armor
Oil of Armor
Real Armor Worn

**Awarded Build Points:** A measure of how many Build Points a character has been awarded. It does not include the starting Build Points.

**Basic Career:** Refers to any of the three basic skill lists in Chapter 3.

**Body Points:** A measure of the amount of damage a character can take. The character’s base Body Points are determined by the skills they have purchased. All types of Body Point bonuses are stackable, but Body Points from the same source are not. For example, a character can only have one *Stamina* Spell or receive the benefits of only one *Stamina* potion.

There is an order that the character’s Body Points are lost; different types of Body Points are lost in the following descending order:

Type of Body Points
<i>Stamina</i> Spell
<i>Heroism</i> Song
<i>Barkskin</i> Spell
Magical Body
<i>Stamina</i> Potion
Base Body Points

**Build Points:** A measure of how much skill and how powerful a character is. Also, Build Points are used to purchase new skills for the character. Every skill has a Build Point cost associated with it.

**Character:** This refers to any in-game persona a player has. A player’s character, an Orc Shaman, a Troll, a farmer, and a Golem are all characters. It does not matter if the character is a PC or NPC, they are all characters.

**Damage Bonus:** A measure of the damage a character can deal with their weapon. All weapons have a base damage determined by the type of weapon it is. All Damage Bonuses are stackable but not from the same source. The exception is Damage Bonuses from skills such as the Proficiency skill, the Backstab Skill, and Assassin Proficiency skill. These are all stackable with themselves. For example, a character with 2 Proficiency skills, 2 Master Proficiency skills, 3 Assassin Proficiency skills using a One-Handed Edged weapon would deal 9 points of damage with each swing.

**Damage Resistance:** Some characters are not affected by some types of weapon attacks. These characters have Damage Resistance and require special weapon materials to affect them. There are three levels of Damage Resistance: Silver, Mithril and Magic. This denotes the minimum special weapon needed to hurt the character. So a character who has Damage Resistance: Mithril is only hurt by Mithril or Magic damage.

**Death Count:** The time during which a character is dying. Once a character is Bleeding to Death, Mortally Wounded or at the Brink of Death, they are in their Death Count.

**Defense that Stops Physical Attacks:** Refers to any skill, spell, ability, or magical effect that will protect the character from physical damage. *Invulnerability* spell, Ritual of Defense, and Dodge are all examples of a defense that stops physical attacks.

**Defense that Stops Magical Attacks:** Refers to any skill, spell, ability, or magical effect that will protect the character from magical affects and damage. *Absorption* spell, Ritual of Spell Shield, Redirect skill, Resist Spell skill, and Dodge are all examples of a defense that stops magical attacks.

**Eldritch Effects:** This type of effect is indicative of the attacks and effects of higher powers. For example, the breath of Drakes and Dragons are Eldritch in nature. This is not to be confused with the Pyrotechnics School of magic. Even though the verbal says, “I summon forth an Eldritch...” it is not a true Eldritch attack.

These attacks are only stopped by: the Dodge skill if it is not an area of effect attack, Resist ability or effect, a Ritual of Eldritch Shield, and Elemental Protection. Shields of any quality do not stop the attack. Soaks and Thresholds of any strength are bypassed by these attacks. Armor will protect the target character normally. *Magic Sanctuary* spell, *Wall of Force* spell, *Haven* spell, *Wards*, and Circle of Protection will stop Eldritch attacks.

If a character is reduced to -1 Body Points by an Eldritch attack, they are immediately brought to the Brink of Death and are left as a smoldering stump with no limbs or head. Additionally, all items – magical or otherwise – are destroyed, except for artifact level items. Rituals cast upon the character remain unaffected.

**Event:** A regular monthly scheduled event. Most events are three days long, Friday night to Sunday afternoon. Some Events last longer, Friday night to Monday afternoon; these special four day events take place on Memorial Day and Labor Day. Other events only last one day, like a holiday party.

**Greater Undead:** A type of undead that is intelligent and able to learn skills. The following are examples of greater undead: Death Knight, Death Mage, Death Assassin, any other Lord class undead, Mummy, Vampire, Death Lord, and Lich. Some undead are the greater version of their type of undead but they are still not greater undead. For example, a Greater Skeleton is still a lesser undead.

**Incorporeal:** Characters that are incorporeal have no physical form and cannot do anything that requires a physical form. They cannot pick anything up or wear armor. Just because an incorporeal character is affected by an attack – magic for example, it does not mean they may manipulate that in any way, shape or form. A Wraith cannot pick up a magic sword and run away with it, for example.

Incorporeal characters may pass through solid, non-living, non-magical objects by saying, “Phasing” loud enough for people to hear. The following exceptions apply. **A player may never, ever call a Hold to phase.** A phasing character cannot stop halfway through and “hide”, they must pass through immediately. A character can only phase through doors or other portals the player can actually move through. A player may not call a hold to move to the other side of a window; they have to actually go through the window or door. The player is always in-game and can be attacked or harmed while phasing. If a wall is represented by a tarp or similar out-of-game physical representation, the player may phase through it by going under or through a seam – non-destructively of course, but they are always in-game.

**Latent Spell:** Any low magic, Nature Magic, Spell Song spell, or ritual that can be invoked either in defense of an attack or to be used without preparation. For example, the *Negation* and *Invulnerability* spells are latent defensive spells; a *Giant Strength* spell or *Ice Brand* spell are examples of latent spells that are not defenses.

**Lesser Undead:** A type of undead that may or may not be intelligent but cannot learn skills. The following are examples of lesser undead: Zombie, Skeleton, Ghoul, Revenant, Death Slave, Specter, Wraith, Shadows, and Shades. Some undead are the greater version of their type of undead but they are still not greater undead. For example, a Greater Skeleton is still a lesser undead.

**Line of Sight:** The player must be able to see their target in order to effect or maintain a skill, spell, or ability. The player may take a single step or lean to verify they can see their target. The character does not have to be looking at the target and minor obstructions such as people or a tree do not block line of sight, a solid large obstruction such as a building will. If the character moves behind foliage that prevents them completely from seeing their target, line of sight is broken. Line of sight is also broken if the character is rendered Unconscious, but not blinded.

**Monster Cabin:** This is also called the NPC Cabin. This is where a player goes for their NPC work shift to find out what they are doing. It is the command center for the Plot Committee and the NPC’s.

**NPC:** This acronym stands for Non-Player Character, which refers to the roles a player plays that are controlled by the Plot Committee and are sent out from the Monster Cabin.

**NPC Cabin:** This is also called the Monster Cabin. This is where a player goes for their NPC work shift to find out what they are doing. It is the command center for the Plot Committee and the NPC’s.

**OCFS:** An acronym for Opening Ceremonies Fact Sheet. The OCFS is found at the Logistics area at each Event. It contains all the important things you need to know for the Event. Things like: safety issues, special rules, important announcements, information about the weekend from the Plot Committee, etc. Every player is responsible

for knowing everything in the OCFS. Not reading it is not an excuse for not following the rules!

**PC:** This acronym stands for Player Character which refers to the character the player plays and is in control of.

**Player:** This refers to the real world, out-of-game person who plays LAIRE. Everyone in our game is a player and they all play characters.

**Resist Ability:** This defensive ability will stop any and all attacks or affects that effect the character. After calling this defense the character is Torso Stunned for 5 seconds, even if the character is normally not affected by Torso Stuns. **The Torso Stun cannot be stopped or resisted in any way.** While Torso Stunned, the character may call another Resist if they have it, but they are Torso Stunned for an additional 5 seconds. For example, a character calls a Resist when they are already stunned for 2 seconds; they would have another 8 seconds to count off before the stun effect ends.

**Shadow Walk:** This ability allows a character to move from one shadow to another. There must actually be a shadow where the character starts and stops their travel. To use this ability, the player must say loudly enough to be heard, “Shadow Walk 1, Shadow Walk 2, Shadow Walk 3.” When the character arrives at their destination they must say the same thing again. While in their count, a character is vulnerable to attacks and cannot parry, but may use marshal or magical defenses. To represent their out of play status, the player should put their weapons or claws over their head.

When Shadow Walking, the character is completely unaware of the in-game world around them. They cannot listen in to conversations or wait to appear. The character must choose their reentry point at the time they Shadow Walk. The target area must be specific but does not need to be in line of sight.

**Skill List:** A collection of similar skills. The Basic Career Skill Lists cost the character 10 Build Points to purchase and have an on list and off list cost. The Advanced Career Skill Lists have no cost associated with them but are grouped and have prerequisites to give the character a choice of skills to learn for that Advanced Career.

**Spell Defense:** Any low magic, Nature Magic, Spell Song spell, or ritual that protects the character for some kind of attack or effect **and** is latent. A *Negation*, *Invulnerability*, *Elemental Protection- Fire* and a Spell Shield are all examples of Spell Defenses. An *Armor* spell is not a Spell Defense as it is not latent.

**Soak:** A Soak is a type of defense that protects the character from physical attacks by subtracting its value from all damage. So a 5 Soak would subtract 5 points of damage from every physical attack. If a character was struck with an attack that did 4 points of damage, they would take no damage and if the character were struck with an attack that did 10 points of damage, the character would take 5 points of damage even if that attack did direct Body Point damage. Thresholds are applied before Soaks.

**Strength Bonus:** A measure of a character’s strength relative to a normal human. Every point of strength adds to the damage done with a weapon. So a +2 Strength Bonus would allow the character to deal two extra points of damage with their attack. There are many different sources of Strength Bonuses. Some races have a natural Strength Bonus, some spells will give a character a Strength Bonus, some alchemical items will give a character a Strength Bonus, some skills give the character a Strength Bonus, etc. All of these Strength Bonuses stack with each other. However, except for the Feat of Strength skill, Strength Bonuses from the same source do not stack. A character cannot use two *Giant Strength* spells to gain a +6

**Strength Bonus.** For example, a character can use a *Giant Strength* spell, a +3 Giant Strength potion, a Feat of Strength skill, and a Holy Blessing skill to gain a +10 Strength Bonus.

Most Strength Bonuses will allow a character to perform a feat of great strength and last for 15 seconds. For example, a character with a +3 Strength Bonus can carry a character and run with them.

If not specified, the Strength Bonus is “per hand combinable” which means that if the character uses both hands on a weapon or both hands to perform an action their bonus doubles. “Per hand non-combinable” means that the bonus will not double if the character uses both hands. If the character has some Strength Bonuses from a combinable source and others from a non-combinable source, they still stack, but only the combinable strength will double with the use of two hands. In the above example, the character would have a +10 Strength Bonus with one hand and a +11 Strength Bonus with two hands since only the Holy Blessing is combinable.

When performing a feat of great strength, characters can work cooperatively. All Strength Bonuses are cumulative and for every character after the first, the bonus increases by +1. So if three characters with no Strength Bonus attempt to open a door, their combined Strength Bonus would be +2.

When carrying another character, both players must be present. A character cannot grab another character and run away leaving the slower, carried character behind. Therefore, the carrier and the carried must move at the slower of two players speed. The carried player must, in all fairness, move at their fastest possible speed. Any attempt to prevent being carried away in this manner will be dealt with as cheating.

**Every full +3 Strength Bonus the character has allows them to throw another character 5 feet.** If a character throws someone horizontally, they are always throwing them half as high. So, if a character throws someone 20 feet, they will go 10 feet high, and you need that much clearance to do so. A character can throw someone straight up at half the normal distance. A character can “cannonball” someone, i.e. throw them with no arc, at one quarter the normal distance. No more than 4 characters at one time can throw one person. **There are NO other options, no changing trajectories ever – only the standard 0 degrees, 45 degrees, 90 degrees is allowed.**

*For example, four characters want to throw one of their buddies over a pit. The pit is 30 feet wide*



*and the ceiling is 10 feet high. They have a combined Strength Bonus of +27. This would allow them to throw someone 45 feet, but they would also go 23 feet high and hit the ceiling. This throw is impossible. They realized this and decide to throw their buddy with no arc – a cannonball. With their combined Strength Bonus, they could throw their buddy 12 feet straight; well short of the other side of the pit. They party is going to have to find another way around the pit.*

Any feat of great strength is at the marshal’s discretion.

**Tag Cycle:** Every normal LAIRE event is broken down into four Tag Cycles. Some events last longer and have two extra Tag Cycles, other special events last only one Tag Cycle. Some skills, Power Points, Elemental Pool Points and Spell Singing Points are only useable a limited number of times in a Tag Cycle. When the character runs out, they cannot use that skill until the next Tag Cycle. Below are the times and tag color for the different Tag Cycles.

Time	Tag Color
Lay-On to Saturday 7am	Pink
Saturday 7am to Saturday 7pm	Blues
Saturday 7pm to Sunday 7am	White
Sunday 7am to Closing	Green
<b>For Special Four Day Events the Tag Cycles are Extended:</b>	
Sunday 7am to Sunday 7pm	Green
Sunday 7pm to Monday 7am	Varies
Monday 7am to Closing	Varies

**Tagged Skills:** Some skills are only usable a limited number of times per Tag Cycle each time they are learned. For example, the Slay skill can only be used once per Tag Cycle every time it is learned. At the beginning of the next Tag Cycle, the character once again has access to these skills. An unused skill cannot be saved or used in the following Tag Cycle. When you check in at Logistics, you will receive your Character Card and a tag for every Tag Skill you have.

**Threshold:** A Threshold is a type of defense that protects the character from physical attacks, so long as it is not exceeded. If the Threshold is exceeded, then the character takes full damage. For example, a 4 Threshold would protect the character from any type of damage that is 4 points of damage or less, even attacks that do direct body damage. If the character is hit with an attack that does 5 points of damage, they would take all 5 points. Thresholds are applied before Soaks.

**Torso Stun:** An affect that renders the character unable to do anything except stagger around helplessly. The character may not take any offensive actions, cast spells, use any skill, invoke any latent spell, or speak while they are under the effects of a Torso Stun. Any innate racial defensive skills or abilities can be used. For example, Outlander Resist, Eleven Resist or Dwarven Resist skills or the Resist ability.

**Total Build Points:** A measure of how many Build Points a character has. It includes the



starting Build Points and Awarded Build Points.

**Unobstructed Line of Sight:** The skill, spell, or ability requires a line of sight to the target that is not hindered by any obstacle, in-game or out-of-game, even if the character can see through the obstacle. If a spell packet can travel from the character to the target, however improbably, the skill, spell or ability will take effect. For example, a grate is between the character and the target, if the spell packet fits through the grate the skill, spell, or ability will pass, conversely if the target is behind a *Wall of Force* spell, a glass window, or a window screen, the spell packet could never travel to the target, so the affect fails.

## General Rules

### The Hold Rule

**The most important combat rule is the Hold Rule, which can be invoked by any player at any time.**

#### *What Happens When You Call a Hold*

When someone calls the word “Hold,” you should stop what you are doing immediately, and stay exactly where you are. Do not leave the spot you are standing on, players who move without good reason during a Hold should be reported to a Marshal. Do not have any conversation during a Hold, in-game or out-of-game, unless it relates to the specific reason why the Hold was called.

#### *How to Call a Hold*

To call a Hold, shout, “Hold” as loud as you can. If you hear the cry of, “Hold” you should repeat it at once, and then stop any action you are involved in. In combat situations, be sure your opponent has recognized the Hold before dropping your guard.

When the reason for a Hold has been resolved, the player who called the Hold or a Marshal should call “Three, two, one... LAY ON”. The game then resumes from where it left off.

#### *When to Call a Hold*

The main reason to call a Hold is for a safety reason. Safety reasons include the following.

- A personal injury
- A combat rules violation, such as
  - Another player strikes you in the head or groin
  - A player is striking you too hard
- You see something that may endanger you or other players
  - Rocky or dangerous terrain
  - Broken glass on the ground
  - A pit or a hole
  - A child or a non-LAIRE member entering the play area
  - Spotting broken weapons or armor
  - Players entering an out-of-game area

You can also call a Hold for a rules related reason, such as clarifying the effects of a spell. This is mildly discouraged, since there is nothing more distracting during a battle than a stream of Holds for trivial reasons. If there is a rules problem in the middle of a battle, try to work it out quickly without calling a Hold. It is common courtesy for players not involved in the clarification to pause and wait for those involved to be done before continuing. Be aware of your surroundings and what the other players are doing.

#### *What is not Allowed During a Hold*

Players may not call a Hold for personal convenience or to perform any out-of-game activity that has an affect in-game. For example, it is illegal to call a Hold in order to gather spell packets or arrows. If a Hold is called for another reason, you are allowed to gather spell packets but you must be back in the place where you started when the LAY ON is called. You may not gather thrown weapons or arrows since these items are in-game.

**No in-game conversation, discussion of tactics, or other talking should occur during a Hold.** Only the person who called the Hold, the Marshal, and any subject of the Hold should speak while it is in effect. This will shorten the Hold, and keep the flow of the game going. Also, if the Hold was called because of safety reasons, for a Marshal to give an in-game description, or other instructions, you cannot hear it if you are talking. **This cannot be stressed enough, when you hear a Hold called, be quiet!**

Also, you may not call a Hold to compensate out-of-game for in-game challenges. If you are out of breath, stumble, or drop your sword, you may not call a Hold to catch your breath, regain your balance, or pick up your sword.

You may consult a copy of the rules or a copy of the spell verbals during a Hold.

Players who call unnecessary Holds will be cautioned. If the player continues to call unnecessary Holds, they will be disciplined.

#### *The Word Hold In-Game*

You are encouraged to use period sounding speech, but a cry of “Hold varlet! I wish to smite thee” is a bad idea. All those around you will hear and repeat the “Hold” and will ignore the rest of your sentence. Therefore, you should not yell the words “Hold” or “Halt” at all, and you should be cautious about beginning any sentence with the word “Hold.” Instead, use the word “Stop” or “Keep the line” instead of “Hold the line”.

### The First Rule

**If a skill, spell, or other rule does not explicitly state you can do something, then you cannot do it.** For example, the *Giant Strength* spell does not say you can use it to leap any distance, therefore, no matter how creative you may be in trying; you cannot leap with a *Giant Strength* spell. As another example, the Slay skill says nothing about being used to break an object such as a door. During game play your character wants to get into a room behind a closed door. You cannot use one of your purchases of the Slay skill to break down the door.

### Characters and Players

You are a player and your character is the role you take up in the LAIRE game world. Characters are anything played by a player in the game. Orcs, Goblins, Zombies, Dwarves, etc, really any PC or NPC is a character. Throughout this rulebook these two words are used and they are not interchangeable. Be careful when you read this rule book, many of the rules change their meaning if you exchange these two game terms.

### Tag Cycles and Using Skills

**If you do not play in a Tag Cycle you cannot use tags from that Tag Cycle.** This rule applies to PC’s as well as NPC’s.



## Rounding Rules

From time to time a player may have to round a number. Unless otherwise stated, the player should round any remainder in their favor, with a minimum of 1.

## Losing Permanent Pool Points or Body Points

No character can ever be forced by any charm effect to use a skill or ability, cast a spell or a ritual that will expend permanent pool points – Power Points, Elemental Pool Points, etc. – or permanent Body Points. If the character is made to do so, the attempt fails and nothing is lost.

## Acknowledging an Attack

When you are hit with an attack, you should acknowledge the attack by saying, “Got it” when possible and prudent. It indicates you know you were hit with the attack. If you call a defense to the attack it is not necessary to call “Got it.”

## When to Call “No Effect”

If a character is immune to an attack and they are hit with that attack, the player should call, “No Effect.” However, if the attack normally has no visible affect – Charm School spells, charm abilities, the *Take Your Sight* spell, the *Enfeeble* spell, poisons, etc. – the player does not have to call, “No Effect.” The player should still acknowledge they were hit by the attack by saying, “Got it.”

Common skills characters can learn that fall under this skill are the Poison Immunity, some Spell Immunities, Immunity to Charm, and Alchemical Resist skills.

## Halving and Doubling Effects

During game play, a character may acquire items or abilities that either halves the cost for using a skill or spell or doubles its effects. **No matter what or where it comes from, no spell, skill, ability, power or effect can be both halved and doubled and it can only be halved or doubled once.** There are no exceptions to this rule. If the character does have two of these effects, each time they use the spell, skill, ability, etc. they can choose whether to double the effect or half its cost.

The one and only exception to this rule is the skill Double Power. While it can never be combined with another doubling effect, if the character has something that halves the cost for the spell, it can be combined with the Double Power skill.

This rule also holds true for items or abilities that reduce the cost for using a spell, skill, ability, etc. These effects cannot be combined with themselves, with halving effects or doubling effects.

## One Strike Combat Rule

Engaging in combat in a manner that is dangerous to yourselves or others will not be tolerated. Every player gets one warning per Event given to them by a Marshal. Any player receiving a second combat warning in that same Event will be removed from all combat for the duration of the Event and have to attend a combat retraining class before they will be allowed to fight again.

For example, a character who ducks low, thereby presenting their head as the primary target, is endangering themselves. If the player gets hit in the head, it is their fault, not the striking player, and they will be given a combat warning.

On the other hand, a player who aims for their opponents shoulder is asking for trouble as this increases the likelihood of striking their opponents head. The player who delivered the blow, in this case, is at fault and will be given a combat warning.

## Courtesy

LAIRE tries to promote personal growth as well as the growth of a character’s Level. So, while in-game your character may be a rude, crude, crass, stupid, bore, you need not be one as well.

If you need to talk to someone, especially someone who is volunteering a considerable amount of their personal time to be a Marshal, Staff, Plot Marshal, or E-Board member, it is rude and insulting to walk up to that person while they are already engaged in a conversation with another person and interrupt with your request or issue. The other player who you just pushed aside has as much right and need as you do. The polite, and only acceptable, behavior is to approach and wait quietly to be acknowledged or the conversation to end. This is not an invitation to eavesdrop on a conversation that does not concern you. That is almost as rude.

Similarly, approaching a person while they are in-game and you are out-of-game and starting to talk to them is also rude. Approach and wait to be acknowledged if they are roleplaying, or politely and quietly inform the person that you need to talk to them out-of-game.

Of course if there is an emergency and you need to talk to someone, then by all means interrupt, but do it courteously by first saying, “Excuse me,” then apologizing to the person you are not going to speak to, “I’m sorry for interrupting, but this is an emergency.” Then go on with your explanation. Everyone deserves to be treated with respect and courtesy, even you.

It is also important to be conscientious about your personal hygiene. It is difficult to roleplay or otherwise interact with another player if they – to put it bluntly – stink. As someone once said, “Water is not just for drinking, it is for bathing too.” Be sure to bathe before, during, and after during an Event as well as brush your teeth and use plenty of deodorant.

## Calling other Players on Mistakes

Sometimes a character will make a mistake using a skill. Some of these mistakes are in-game mistakes, such as flubbing a verbal. Some are out-of-game mistakes, like striking a player in the foot with the Slay skill. In either case, the skill, spell, or effect fails. However, if the mistake is in-game, the player should point out why they are not taking the effect. For example, a character casts a fireball by saying, “I draw upon the earth to cast a fireball.” The targeted character should call “Flubbed verbal”. On the other hand, if the error is an out-of-game mistake, they should call “Out-of-Game Error”. The character using the skill has the right to ask for a Marshal to make a call as to whether the skill was used correctly. The target character in either case does not have to correct the character using the skill.

## In-Game Versus Out-of-game

After getting this far in the rules, you probably know what is meant by being “in-game” or “out-of-game,” but here is the formal

definition: you are in-game when you are interacting with the game world of LAIRE. You are out-of-game when you are not interacting with the game world, whether you are attending to some logistical necessity such as a Tag Exchange; a personal errand such as going to the bathroom; or the ultimate disappointment, the game is over until next month.

### ***In-game Behavior***

The game is better if you stay in-game as much as possible. Try to keep out-of-game comments to a minimum; yes, we have seen *Monty Python and the Holy Grail* as many times as you have. Let us take the Hamlet analogy: it may seem funny to the actor playing Hamlet to stick in a line from *A Streetcar Named Desire*, but chances are it will just make the audience fidget; after all, they came for a good performance of Shakespeare, and the joke just spoils the experience. All of us work together to create the illusion that we are participating in a fantasy world; no one likes it when their work is spoiled.

### ***Out-of-game Behavior***

**If you are out-of-game for some reason – you are tired and taking a break, you are walking to a phone to make a call, you are a spirit and you are going to the Healers Guild to be resurrected – do not interact with the people in-game.** Stay out of areas where there are crowds or combat. If you are out-of-game, stay completely out of the game until you are ready to go fully back into the game; do not hold in-game discussions with other players, or yank off your white headband and go rushing to attack a nearby Orc.

On the other side of the coin, if you see someone wearing a white headband or wearing regular street clothes, ignore them while you are in-game. Obviously there are exceptions to this but try to avoid all out-of-game contact while you are in-game. At best, you would be distracting yourself from your own roleplaying; at worst you could be interfering with other players' enjoyment of the game.

Of course, there are times when you must ask a quick rules question or take a moment for a quick out-of-game activity. Try to keep these actions as brief as possible.

### ***Going In- and Out-of-Game***

**The basic rule is simple, wherever you went out-of-game is where you should come back in-game.** If you put your white headband on in your room in the inn and went to your car, you should come back in-game in your room when you are done. There are some exceptions to this, most notably if a Marshal asks you to put your white headband on for some reason he will generally tell you where and when you can take off your headband and come in-game. The other common circumstance is when you resurrect; when you put your white headband on and become a spirit, wherever you resurrect is where you come back in-game.

The other rule is when going out-of-game or coming back in-game, make sure you are not involved in anything. You should step away from any crowds or if something is going on right in front of where you went out-of-game, wait until it is over before stepping back in-game. For example, if you went out of game by the edge of a field near where your car is parked and when your return there is a large fight, you should wait until it is over before coming back in. Similarly, if you are involved in a fight and have to go out-of-game, make sure you walk out of sight of the combat before you put your white headband on.

If you are being chased, hunted or followed, it is also unacceptable to put a white headband on to avoid your pursuers.

### ***Out-of-Game Areas***

Some areas of the camp are always designated out-of-game. The parking lot, the bathrooms, the NPC cabin, out-of-game sleeping areas, and Logistics are all always out-of-game areas. There is no combat or roleplaying allowed in these areas. While you go out-of-game when you enter one of these areas, even without a headband, you cannot run into them from pursuers or other such situations. They are not safe places to hide. The same rules on when and where you can go out-of-game apply to these areas.

There may be other areas of the camp that are off limits and designated out-of-game. Check Logistics for any handouts or attend Opening Ceremonies for any announcements on a month by month, camp by camp basis.

### ***Abuse of the System***

It is poor sportsmanship, not to mention illegal, to go in- and out-of-game whenever it suits your immediate convenience. For example, if you are suddenly surrounded by a group of monsters, you cannot say, "Sorry, I'm out-of-game" unless you were wearing your white headband before they sprang their ambush. Even if you were wearing a white headband, it would be wrong for you to walk over to your friends, say, "Hey, I know where there are a bunch of monsters waiting in ambush. Let's do a counter-ambush," take off your white headband, and lead an attack on those monsters.

You cannot go out-of-game to perform an in-game action. This includes calling a Hold to collect spell packets or arrows, or putting on a white headband to escape soldiers who are searching for you. For the former, you are responsible for bringing enough props to do what you want to do; it is not fair to make other people stop and wait for you. In the latter case, if you want to hide, then hide; if you know people are searching for your character but you are tired and you want to go to sleep out-of-game, tell a Marshal.

There are times when the game can get difficult to play, and you may be tempted to go out-of-game to avoid trouble. Do not do it. Dealing with difficult situations is part of the challenge of the game, and often brings the greatest rewards.

### ***Sleeping In-Game.***

LAIRE runs from Friday night until Sunday afternoon and does not stop in between. Some players are not capable of playing the whole event for medical reasons or otherwise and at every Event, special out-of-game sleeping arrangements can be made. You should speak



to Logistics when you arrive or specify that you need out-of-game sleeping when you pre-register for the Event.

Sometimes during an Event, a player may really need some sleep, gets injured, or falls ill, in these cases that player must receive permission from the Executive Director to sleep out-of-game. Players that go out-of-game to sleep without permission will be given the appropriate disciplinary action. It is unfair to the other players in the game, everyone would like to sleep safe and sound, but that is part of the thrill of the game and part of the risk, and everyone should share in that excitement.

### In-Game and Out-of-Game Information

While playing the game, a player will learn information that their character does not know. Most often, this occurs when the player is NPC'ing. This section will describe what acceptable and unacceptable behavior in our game is.

Regardless of the rules bellow, if at anytime a player hears in-game information that affects their in-game roleplay, they can go to a Player-Rep to have their grievance heard and a suitable resolution to the problem passed down. So watch what you say, you never know who is listening or who may not want to know the information you are giving out.

#### *Player to Player Information*

**Anything one player tells another player about their player character or actions their player character takes can be taken in-game at your discretion.** For example, at the end of an Event, a player may boast, "Wow! What a game I had today! I killed the Duke!" You may take this information in-game and, at the next Event, inform the Duke who killed him.

Be careful where and to whom you tell information about your character. If you are telling your best friend, who you trust not to reveal the information or take it in-game, that you just completed your Dark Cleric quest and have learned your first skill, there may be someone near by that over hears the information and CAN bring it in-game. You have no recourse and will get no special considerations if either your best friend or the eavesdropper brings the information in-game.

#### *NPC to Player Information*

Any in-game information you learn while playing an NPC or discussing storylines with a Plot Marshal must be kept out-of-game. This information may never be brought in-game and may never be discussed with other players without explicit permission from the Marshal.

However, it is acceptable to tell anecdotal stories about your NPC experiences so long as you leave out the unnecessary particulars. For example, you are playing a character on a module. During the module, one of the player characters uses a Servant of Darkness skill and you learn that they are playing such a character. Also, during the fight the same character drops his weapon in a humorous manner. Later you meet up with your friends and want to regale them with the story. So long as you leave out the player's character name, the information about the module itself, and the fact that they are a Servant of Darkness, you may feel free to tell your friends about the humorous incident.

#### *Between Event "In-Game" Conversations*

It is unreasonable to expect the game to monitor, curtail, or control quasi-in-game conversations between characters between Events. It is, however, discouraged.

It is against the rules to plan, conspire, or discuss actions that have in-game effects beyond the characters of the players present. For example, if the Baron of the Dale and the Lord of Lochehart, while at an out-of-game wedding, plan to overthrow the Duke. This is meta-gaming and against the rules. Also, the rule above about player to player in-game information exchange applies. So, if while at this wedding, another player hears the conversation, not only will they be able to bring the information in-game but the two former players will receive the appropriate disciplinary action.

### Player Characters (PC's)

You are a player, and your character is your representation in the LAIRE game world. You have complete control over your own character – subject to the rules of the game – you control how your character feels, speaks, acts, lives, and dies. In contrast, there are non-player characters (NPC's), whose actions are not fully controlled by their players; these are described in a later section.

Your character could become the greatest hero to ever stride across the world, or the most wicked creature ever to have slinked in the shadows, depending on what you want to do and how well you play the game. Remember always – for good or for ill – **in-game actions have in-game consequences.**

### Player Guidelines

#### *Know the Rules*

The better you know the rules, the better a player you can be. Ideally, all the players will know all the rules of the game, but realistically that is a lot of information to know and not every rule in this rulebook is applicable to you or your character. If you are playing a Paladin, you do not need to know how to cast a ritual. As you play the game, you will learn which rules are the most important for your character and which are the most important for you to memorize. You can start off by learning the combat related skills and the low magic spells, as these are the most common, and the ones you will encounter the most.

#### *Be a Good Sport*

This is only a game. Like any well-run game or sport, the rules of good sportsmanship apply. Do not get into shouting matches with other players over the interpretation of the rules; stay calm and call a Marshal. If someone is unfamiliar with the rules or makes a mistake, be tolerant and patient; give the new or poor player a chance to become an experienced and good player. For example, if you are hit in the head, do not lose your cool; call a Hold, explain what happened, and tell them to be careful. If it happens again, do not yell at the other player; call a Marshal. You must treat all players with respect at all times. Failure to do so will result in disciplinary action.

As a player, you may have to be especially tolerant of the people playing the monsters you meet, since as NPCs they are likely to be new members of LAIRE, or people testing whether they like to play the game. In that sense, every player is a living advertisement for the quality of the game. Without new members, LAIRE will become stagnant and dull. By being a good player and a good sport, you help keep the game alive.



If your character has taken enough damage to go to negative Body Points, lie down and play dead. In the big picture of the game of LAIRE, there is no “winning” or “losing,” but it still can be personally disappointing when your character dies. However, it is also a chance to show how good a player you can be: count down the time for when healing spells are still effective as accurately as you can; cooperate with searches according to the rules; follow the rules on in-game possessions as you arrange to resurrect your character.

### ***Do Not Get into Arguments About the Rules***

Rules disputes are a strictly out-of-game activity, and cannot add to anyone’s enjoyment of the game. If the result of an encounter is obvious, do not go thumbing through the rules looking for a saving grace for your character; let the game move on. If you have a rules question ask a Marshal. If you think a Marshal’s call was in error, talk to one of your Player Representatives. They will bring the issue to E-Board and they will take the appropriate actions to rectify the situation.

In particular, do not waste your time arguing over a Marshal’s judgment. Marshals are trained to try to be fair to everyone; if a Marshal rules against you, then they are trying to be fair to someone else. If you feel a Marshal ruled incorrectly, then see a Player Representative immediately.

**If there is a question between a PC and an NPC whether it be taking damage or how a skill or rule works and there is no Marshal present, the PC wins.**

### ***Roleplay***

While you are playing, try to “be” your character. When your character is hit in the leg, try to act as if you were wounded in that leg; when you see a player in a goblin mask, picture them as an actual monster; when your character is surrounded by enemies and all hope is lost, act valiantly or plead for mercy as your character would do. Your ability to interact in the game as your character is what makes the game fun to play and is what will make other players want to interact with your character.

The goal of the game of LAIRE is not to kill all the monsters and “win” the game. The point of LAIRE is to put yourself in the middle of a giant interactive improvisational theater. The organization provides the direction and the stage props, but at every moment the star of your personal theater is you. Play your part well, so you can give yourself a good review when the play is over.

### ***Stay In-Game as Much as Possible***

Make it clear when you are in-game, and when you are not.

Of course, when you are out-of-game you are supposed to wear a white headband. However, there are still times when it is not clear to other players whether you are speaking in-game or making an out-of-game comment, so please call a Hold before making any out-of-game comments.

It is not acceptable and very bad form to interrupt in-game roleplay with an out of game comment or joke. You cannot call a Hold to make a joke or some other off topic comment. If you wish to have such conversations, then you should go to an out-of-game location and go out-of-game. Saying, “Out of character...” and making some out-of-game or out of context comment is absolutely unacceptable. If a marshal catches a player doing this, negative Roleplaying Chips will be written on your card. Repeated offenses will result in disciplinary actions.

The biggest problem is in the area of insults. If you call someone a nasty name or use a real world obscene gesture, they may misunderstand and take it personally. The best solution is never to use blunt language at all; try to come up with medieval sounding equivalents: “You are an illegitimate offspring of a female hound with whom you yourself have mated.” If you treat insult as a high art, not only will players know that you are speaking in-game, but you may earn a Roleplaying Chip for a truly creative put-down.

### ***You are Not Your Character, Your Character is Not You.***

You can play whatever character you wish for your own personal entertainment. You can be a rascally scoundrel, an evil necromancer, a brutish barbarian, or a shining paragon of virtue. But do not get too caught up in the role you have chosen for yourself. Your character may be evil, but as a player you are expected to follow all the out-of-game rules of LAIRE. Do not assume that because someone plays a bad character that they share their character’s traits; some of the nicest people in the world play the most wicked characters in the game. Of course, you should also remember that in-game actions have in-game consequences. If your character attacks a group of necromancers and some get away, you should not be surprised if they come back looking for revenge. Similarly, if you kill the Baron of Islewatch, you should not be surprised if your character becomes an outlaw and is hunted and hounded constantly.

### ***Be Prepared***

You know that you will need a white headband to show when you are out-of-game. You know you will have to carry tags for all the skills your character has. You know that you may be trudging through the woods in the rain. If you are playing a spellcaster, you know you will have to write on your Power Point tags. So, be prepared for all these things: find an old t-shirt that you can tear up for a white headband; make sure your costume has a pocket for all your tags; bring a zipper-lock plastic bag to keep your tags from getting wet; bring a pen. Just like you cannot play hockey without your hockey stick, it is your responsibility to make sure that you are properly equipped to play the game.

### ***Ask for Tags***

After your encounter with other players or NPC’s is finished, ask for the tags for any abilities they have used, any damage they have taken, any spells they have cast, etc. Since the NPC’s and other players always have the right to ask you to show proof of your abilities, you should avail yourself of the same right to ask them.

Just because someone asks for your tags does not mean that you are being accused of cheating; we strongly encourage everyone to ask for tags whenever the opportunity arises. Be cooperative when you are asked for tags. If you discover that someone made a mistake and used an ability or Power Points that they did not have, do not get excited; call a Marshal. If you are the one who made a mistake, try to be fair: “Uh-oh, I thought I had more Body Points left. Okay, I’m dead,” and lie down immediately.

In general, if you discover that a mistake was made in the middle of a combat, do not do the battle over; it is almost impossible to do. Decide amongst yourselves or get a Marshal to adjudicate what a fair result would be, and let the game move on.

### ***One Last Time...***

This is only a game. It is meant to be fun. If you take it too seriously, then it is no longer a game. Then, it is not fun anymore.



## Non-Player Characters (NPC's)

Of all the volunteer work you can do for LAIRE, by far the most important is... cleaning the campsite at the end of an event, but the second most important work you can do is to be a Non-Player Character. The NPC's play all the roles that the Player Characters do not: the monsters, the townsfolk, the princes and princesses in distress, the imprisoned dragon that must be rescued from the evil clutches of a dastardly knight. Someone has to play these parts so the other players can have fun.

### Why be an NPC?

There are many advantages to being an NPC. It is a good way to learn the rules; we recommend that new members of LAIRE start by being NPC's for their first event. When you play an NPC, you get to explore possibilities that your regular character cannot; if your character is a spellcaster, you can get a chance to see what it is like to be a fighter. You can play without worrying about all the complications associated with being a Player Character. Finally, when you play an NPC you earn Build Points, Brownie Points, and Play Credits, which you can use to advance your regular character and hopefully have fun as well.

The primary disadvantage to being an NPC is that you have to play your role according to the instructions of a Module Director, a Monster Marshal, or a Plot Marshal. Most players take this as a challenge; like an actor interpreting a part, they look for ways to have fun within the roles they have been given.

LAIRE will provide costumes, weapons, spell packets, and instruction for all the NPC's at an Event. Bring your own costumes and weapons if you wish; chances are the Module Director or Monster Marshal will be able to fit them into the event somehow. We ask that your clothes have no obvious anachronisms; a plain black t-shirt and black pants are fine. Also, please try to arrive at your work shift on time, so you have plenty of time to get acquainted with your role.



## Guidelines for NPC's

Many of the same guidelines for being a good Player Character apply to being a good Non-Player Character: know the rules, roleplay, be a good sport, take your hits, etc.

### *Know the Rules*

Make yourself familiar with this rulebook as soon as you can. Keep a copy of the rules near your encounter site. Try to memorize the spell verbals and the effects of the different spells. If your NPC has special abilities, make sure you know how to use those abilities.

### *Be a Good Sport*

This is only a game. Like any well-run game or sport, the rules of good sportsmanship apply. Do not get into shouting matches with the players over the interpretation of the rules; stay calm and call a Marshal. If a player is unfamiliar with the rules or makes a mistake, be tolerant and patient; give the new or poor player a chance to become an experienced and good player. For example, if a player hits you in the head, do not lose your cool; call a Hold, explain what happened, and tell them to be careful. If it happens again, do not yell at the other player; call a Marshal. You must treat all players with respect at all times. Failure to do so will result in disciplinary action.

If you have a dispute with another player over the rules and no Marshal or rulebook is available, assume the Player Character is correct and let the game continue. Discuss the issue with a Marshal or a Player Representative after the encounter is over.

### *Obey the Monster Marshal*

Always follow all the instructions for any role that you are given. Even if out-of-game you are a fantastic fighter, if you are told to play a zombie you must fight like a zombie, even though this often means a quick and nasty end. The Monster Marshal will give you role-playing instructions for your character. You must follow these instructions and not go outside what you have been told, even if it is cool or funny to do so. For example, if you are sent out as a kind and friendly healer and told to heal anyone in need free of charge, you should not take it upon yourself to charge as much as you possibly can or rob the bodies of the fallen before you heal them. The marshal has reasons for sending you out with the instructions they do. Taking it upon yourself to do otherwise can cause problems you may not know about and ruin the fun for others.

Generally speaking, players who perform the roles that they are given with both good roleplaying and while staying within their assigned parameters will be given more complicated and intense roles in the future. Conversely, players who fail to do this will be given the most basic roles such as zombies and rocks or they might not even be allowed to play an NPC at all and must find another way to fulfill their work assignment

such as cleaning the NPC cabin.

### ***Take Your Hits***

Nothing is more annoying than a monster that refuses to die. If you have been defeated, lie down and die – well in-game at least. You will have a chance to play another monster soon.

### ***Roleplay***

Be your character. Roleplay according to what the Marshal tells you, but within those limits try to be a person, not just a piece of cardboard to be knocked down. Even a mindless monster is a role: it single-mindedly obeys its commands or pursues its goal.

### ***The Players are not Your Opponents***

This game is not the monsters versus the Player Characters, it is you and the other players working together to have fun. You are playing a role, not just player bashing. If the players are roleplaying, encourage them to earn the roleplaying chips they may get.

### ***Do not Give a Killing Blow to a Player Character***

There are some exceptions to this, and the Monster Marshal or Module Director will tell you if you are one of those exceptions.

### ***He also Serves Who Only Stands and Waits***

The hardest part of being an NPC is the waiting. No matter how bored you get, do not wander off.

### ***Be Available***

If your character has been killed and you do not know where to go, return out-of-game to the monster area and wait for instructions.

### ***Be Prepared***

Bring a white headband and a pouch or pocket to carry your headband and your treasure.

### ***Keep Your Card with You at All Times***

A player always has the right to see your NPC card if they question whether you have a given ability. If you do not have the card, then the encounter never happened. If you are an NPC in a module, the description in the module write-up is the equivalent of a card.

### ***Ask for Tags***

After your encounter with the players is finished, ask for the tags for any abilities they have used, any damage they have taken, any spells they have cast, etc. Since the players always have the right to ask you to show proof of your abilities, you should avail yourself of the same right to ask them.

## **The Tag System**

When the game of LAIRE is played, your character goes on adventures, lives, dies, is hurt, is healed, uses abilities, and learns new abilities from other characters. The part of LAIRE responsible for keeping track of all these things is called Logistics. One of the first things you do each time you attend a LAIRE event is to visit Logistics. After you pay to attend the Event, you will receive cards and tags which specify everything about your character: how many Body Points they have, what skills they know, the number of times

the skill can be used in a day, what spells they can cast, and so forth. Logistics is described in the Organization Chapter in more detail.

## **The Tag System**

LAIRE uses tags, 4 in by 1 in stiff pieces of colored paper with information that relates to objects and game concepts with a corresponding in-game description written on them. For example, a Slay skill tag denotes that the character can use their Slay skill once in a Tag Cycle, or an alchemical item tag will describe what kind of alchemical substance is in the vial or physical representation.

It is important that you carry your tags with you while you are in-game. If you do not have the appropriate card or tag, then you cannot use the corresponding ability. If your item does not have the appropriate tags, you cannot use your item.

Remember, all skill tags and cards are out-of-game and cannot be stolen by anyone in-game. If you have robbed someone's pouch and you discover that you stole their tags by mistake, return them immediately.

## **The Character Card**

The Character Card is stamped or signed to prove that you paid to attend the event. If you do not have your character card with you, you cannot play. If you lose this card for any reason, put on a white headband immediately and go to Logistics where a temporary replacement will be written out. Avoid the hassle; keep your Character Card safe and on your person at all times. If you find someone's Character Card, please give it to Logistics immediately.

On your Character Card you will find your name, your character's name, and a list of all the permanent abilities that your character has. Your Character Card represents all the abilities that are inseparable from your character; for example, your character will always be an elf, always knows Rank 3 Charm spells, and always knows how to wield a small weapon. If anyone asks (out-of-game) for proof that you have an ability, you show them, or a marshal, your Character Card. For example, you would show someone your card if your character cast a *Dominare* spell on them and they wanted proof that your character could cast Rank 4 Charm spells.

When you receive your card at the Logistics area, check that all the Build points and abilities that you gained at your previous event are included on the card. The character card also lists the number of temporary tags (Body Points, Power Points, Armor Repair points, etc.) you should receive for each day of the Event.

The back of your Character Card is used to record all the permanent changes made to your character during an event. If your character learns a new skill, the teacher writes the name of the skill and their initials and player number on the back of the card. If you go through a module, the Build Points awarded are noted by a Marshal on the back of the card. If your character is killed, the additional death is noted on the back of the card by the person who resurrects you.

## **NPC Cards**

Both the player and non-player characters must carry cards that identify their skills, abilities, and Body Points. While player characters (PC's) carry the tags described above, the non-player characters (NPC's) usually carry just a single card with their character information.

If you encounter an NPC, you have the right to ask to see their card if you want to verify that they have an ability they are using, or even to prove they have been given permission to play an NPC by a Monster Marshal. If they do not have a card, then they are out-of-game; the encounter with the NPC never happened.

However, there is one case in which NPCs are not required to have a card with them. This is when they are part of an encounter or a module, in which case their character is described in the encounter or module write-up itself.

### Character Tags

---

These are the tags every character receives with their Character Card. Some tags every character will receive, like Body Point tags. Others represent how many times a Tag Cycle you can use a skill or ability. Lastly, there are pool point tags that represent how much power a character has to use abilities or cast spells.

#### *Body Points*

These tags keep track of how much body a character currently has. When your character takes damage, you should hand over your used Body Point tags to the player that did the damage during a Tag Exchange. When you are healed, you should take the pool points associated with the type of healing you have received and have the caster note how much was healed on the back. These now represent your new Body Points. Since Body Points are not Tag Cycle specific, they are always red in color. Body Point Tags come in denominations of 5 Body Points only.

#### *Skill Tags*

Some skills in our game can only be used a limited number of times in a Tag Cycle. When you check in at Logistics, along with your Character Card, you will receive one skill tag for each purchase of a tagged skill for each Tag Cycle. You can only use the tags for the current Tag Cycle. Some examples of tagged skills are: Disarm, Critical Attack, Slay, Weapon Accuracy, Assassinate, Assassin Strike, Total Power, Recover Power, Shape Change, Turn Lesser Undead, Greater Magic Weapon, and many, many more.

#### *Pool Points*

Power Points, Elemental Pool Points, Spell Singing Points, Healing Pool Points are all examples of pool points that the character may have. Pool points do not do much on their own; they are primarily used to power spells or other effects. For example, Power Points are used to power low magic spells. All pool point tags are color coded for a specific Tag Cycle, and only tags from that cycle can be used.

### Tag Exchanges

---

As you play the game, you will give players your tags to represent the use of your abilities. For example, if you repair someone's armor, you will give them the used Armor Repair tags to use as replacement Armor Points; if you cast a *Heal Person* spell, you will give that person the Power Point tags to use as replacement Body Points; if your character is damaged, you will give your attacker the Body Point tags for the amount of damage you took; if you Slay someone, you will give them the Slay skill tag. The specific use of each type of tag is described under the associated skill in Chapter 5.

Used tags must always be disposed of in some way; they are never recycled back into the game. You may be required to write on the tags to indicate their new use; for example, when Armor Repair tags

become Armor Point tags. In this case, keep the newly created Armor Point tags with the rest of your Armor Point tags and use them whenever you would normally give away Armor Points. A tag that indicates a one use skill or spell should be torn in half by the target to indicate it has been used. Since we must clean the camp before leaving, please do not throw the tags on the ground; rip them up and put them in your pocket until you can throw them in the trash.

Never hesitate to ask a player for a tag or some other proof that they have a given ability. Likewise, do not take offense because someone asks you for a tag; it is a necessary part of the game. The exchange of tags helps Marshals to verify that no rules have been broken, and helps players keep track of what their character's current pool of abilities are. There are times when tag exchanges are momentarily inconvenient: obviously, do not stop a combat just to exchange tags, but be sure to adjust your tags before the NPCs, or your healers, wander off.

Do not be tempted to short cut the tag exchange procedure. Here is an example of why: You are attacked and damaged by a monster, then the monster runs off. A spellcaster casts a healing spell on you, saying "Do not bother tearing off your Body Points. I'll just tear up the Power Points I'm using." The spellcaster walks away. Then the NPC playing the monster comes back out-of-game, and asks you for the tags for the damage that the monster did. Now you are stuck, because you cannot show any proof to the NPC player that you received a healing spell.

All skill and pool tags are color-coded. You will receive all the tags for an event at the beginning of an event, but you may not use a tag if it does not have the appropriate color for the time of day in which it is designated. For example, if you are told that blue tags are to be used from dawn to dusk on Saturday, you may not use your blue tags on Friday or Sunday. This rule only refers to unused tags; if a latent spell was cast on you on Saturday, the blue tags representing that spell are still good on Sunday of the same Event.

**If you do not play in a Tag Cycle you cannot use tags from that Tag Cycle.** This rule applies to a PC as well as to an NPC.

### Component Tags

---

Alchemists and Sorcerers use components to practice their craft. Alchemists use components to make their alchemical items and sorcerers require them to cast rituals. Every recipe or ritual outlines what components are needed by the character to create that effect.

There are three basic kinds of components: parts dissected from other characters, parts from plants, and gems or stones. While the character may find any of these during game play, and may even be able to collect them with the proper skill, these components may be purchased at the Alchemist's Guild, the Guild of Arcane Lore, or from the Merchant's Guild. The character can usually find the component cheaper from the former two rather than the Merchant's guild. Also, due to rarity and demand, not every component will be available all the time.

Components that come from characters and plants have a date on the tag indicating when the component was collected. Components do not expire or lose their potency over time; however, sometimes freshness counts, and it may be appropriate for the Marshal to give a bonus to the success roll. The individual creation or casting rules will give the appropriate rules regarding such bonuses.

On the tag there is a line for a description of the item and a place for the player who identified it to initial and sign their player number. This information is in-game and must always be valid. Since it is in-



game, if the character has the appropriate literacy, they can read the tag and identify it. This does not stop a character from mislabeling the vial the component is in, however.

All components must have a physical representation or vial. A player cannot have their character carry a stack of component tags while they adventure. It is acceptable to have just tags and no vials or physical representations when a character has his items in its place of storage, but if the character takes them out of their room, they must have a physical representation.

If a character does have tags without any kind of physical representation while out of their place of storage, the player will lose the components.

### ***Getting Tags for Parts Dissected During Game Play***

Any player with the Dissection skill can get Component Request tags from the Treasure Manager. These tags have a line for what was dissected, when it was dissected, and a place for the initials and player number of the player who played the character being dissected. At the end of the Event, the player should place all their component request tags into an envelope with their name on it and hand it over to the Treasure Manager who will write out the tags for the player over the month. The Treasure Manager will return any tag that is not on the official component list. You still have the component should the need for this component arise, but no numbered tag will be written out until it has an official number. Additionally, the Treasure Manager is under no obligation to write out any component tags for players at an Event. If you want to use your components in-game, make sure you hand them in to the Treasure Manager.

## **Alchemy Tags**

Every alchemical item has a tag associated with it and a unique number indicating what kind of alchemical item it is. If the item is new or unique, on the back of the tag there will be a description of the effects of the item. This descriptive information is out-of-game.

On the tag there is a line for a description of the item and a place for the player who identified it to initial and sign their player number. This information is in-game and must always be valid. Since it is in-game, if the character has the appropriate literacy, they can read the tag and identify it. This does not stop a character from mislabeling the vial the component is in, however.

All finished products must be in a vial. A player cannot have their character carry a stack of finished items while they adventure. It is acceptable to have just tags and no vials when a character has their items in their place of storage.

## **Item Cards**

In-game items such as magic items, weapons, and armor have an Item Card associated with it. Every in-game item needs an out-of-game card that has the item description on it and what in-game effects the item has. The character must carry the item card on them at all times; it is like the Character Card for the item. If a player finds an item with a number on it, they can attempt to identify it and if a Marshal is present they may have the information and the item card. If no item card is available, the player can go to the Treasure Manager or Plot to find the item card.

The item is what truly matters, and if there is no physical representation or only an item card, then the item does not exist.

### ***Magic Item Cards***

Every magic item has a Magic Item Card with the item number that is engraved on the item. The card describes what the item looks like, what the base value of the item is, what rituals have been cast upon the item, and what their effects are. The card will indicate if the magical effects are permanent, charged, or last a certain duration. For items that have spell effects, the card will also indicate whether the spells are Castable or Invokable. Magic Item Cards are always red in color.

Characters that have rituals cast upon them, whether permanent or temporary, need to also have a Magic Item Card. Instead of an item number the player number and character name is used.

**The player is responsible for and required to get any tags needed for their magic items from Logistics when they check in.**

### ***Weapon Cards***

All weapons, except arrows and rocks, require a Weapon Card to be attached to the weapon at all times. If the player finds a weapon that does not have a Weapon Card attached to it, they should assume the weapon is out of game. If it is an NPC weapon, they should give it to an NPC or bring it to the NPC Cabin. All other weapons should be brought to Logistics so the player can reclaim their weapon.

All weapons must have a physical representation. A player cannot have their character carry a stack of weapon cards while they adventure. It is acceptable to have just a card or physical representation when a character has his items in its place of storage, but if the character takes them out of their room, they must have a physical representation.

Normal weapons get normal Weapon Cards that indicates the player's name, the character's name, the weapon class, the Marshal who approved the weapon's creation and date of creation.

Weapons of quality and magic weapons have the following information on the card: item number, physical description, magical effects or modifications, Marshal's signature and date. These weapons all belong to LAIRE, and the item card should never be removed from the weapon, rather the entire weapon is always passed on to whomever finds it. The sections below on stealing have more information on this.

The color of the card depends on the type of weapon it is and is given in the table below.

Weapon Type	Color
Normal Weapon	Gray
Weapon of Quality	Blue
Magic Weapon	Red

Normal weapons also include weapons with any temporary smithing or alchemical effects like silver coatings or an *Oil of Sharpness*.

### ***Armor Cards***

Every suit of armor is evaluated when the character first attempts to bring it in-game by an Arms Marshal. The exact Armor Points for the suit is recorded on the Armor Card or Cards. Every separate piece of armor gets its own Armor Card. The player's character then brings the card and the physical representation for the armor to the Armory and purchases the suit in-game.

All armor must have a physical representation. A player cannot have their character carry a stack of Armor Cards while they adventure. It



is acceptable to have just a card or physical representation when a character has his items in its place of storage, but if the character takes them out of their room, they must have a physical representation.

The color of the card depends on the type of armor it is and is given in the table below.

Weapon Type	Color
Normal Armor	Gray
Armor of Quality	Blue
Magic Armor	Red

Normal armor also includes armor with any temporary smithing or alchemical effects, like an *Oil of Armor*. Armor of Quality refers to Elven, Dwarven, or Enchantment Quality crafted suits of armor.

In addition to the Armor Card, the player will also need to keep track of their Armor Point Tags.

### In-game, Out-of-Game, In-Play Items

Everything at an Event falls into one of three categories: in-game, out-of-game, and in-play. By now you should have a good feel for the difference between in-game and out-of-game and how it pertains to things you will come across as you play the game.

**In-game** items are anything that have an item card, tags, item number, or are property of LAIRE. Coins, alchemical items, special weapons, magic items, scrolls, gems, jewelry, etc. are all examples of in-game items. Locations can be in-game too. The Inn, the House of the Sun, the Druid's Grove, the Armory, the Healer's Guild, and indeed most of the camp are in-game places. Even players can be in-game. These are all objects, places or people that you can interact with in-game.

**Out-of-game** refers to any object that is not represented in-game. Your car keys, your car, food, camp signs, etc. are all examples of out-of-game things. While you play the game, you should treat these items as either not being there or how you would in the "real" world. For example, if you find a set of keys in the Inn, you should not try to sell them to the Merchant's Guild, instead you should bring them to a member of the E-Board so their owner can find them. Also, if you see someone's wallet on their bed, you should not take it, even if your character is a thief, because that is called stealing and is not tolerated by LAIRE at all.

Places such as bathrooms, the parking lot, the ranger's house, the smoker's area, the NPC cabin, Logistics area, etc. are all examples of out-of-game areas of the camp. Whenever a player enters an out-of-game area, their character is considered out-of-game and no in-game activity can take place there, including in-game conversations. Some areas of the camp may be designated out-of-game, either because there is some physical hazard, that part of the camp is being used by someone else, or that section of the camp is being used for modules or a special encounter and your character has to find out in-game how to gain entrance – usually by finding the hook to the adventure being run there. If your adventuring accidentally takes you into an out-of-game area, you should quickly move back out. Similarly if you see someone entering an out-of-game area that has been specially designated as out-of-game, you should politely warn them. For example, if you are being chased by some Orcs and you find yourself in the middle of a module, stop running. Wait for the players of the Orcs to catch up and both of you should move to a different section of the camp and continue your chase.

Some people are out-of-game. Anyone wearing a white head band is always out-of-game and you should ignore them in-game. That does not mean you also ignore them out-of-game because they may have important marshaling information for you. Sometimes the person who is out-of-game may not be wearing a white head band, but it is still obvious they are not part of the game. The ranger, someone's parent, vendors or people visiting the game are some examples. If you are ever not sure if a player or person is in-game or out-of-game you should politely ask them, but if everyone is following the rules, this should be a rare occurrence.

In-game and out-of-game is usually straightforward, obvious and easy to determine. However, there is a gray area called in-play that you should pay particular attention to. **In-play** items refer to anything that belongs to a player but their character uses. Things like costuming, room or module decorations, jewelry that does not have a number, props without a number on them, a noble's banner, etc. are examples of in-play items. These things are there to enhance your game play and to help your suspension of disbelief. They are not there to be taken or damaged; they are another player's property. They can be stolen in-game only by placing a note or, with great care, moving the items under a bed or into an out-of-game area nearby.

It is important to remember that these things belong to someone. You cannot remove them from the player or the player's sleeping area. For example, you are playing a necromancer and are told to go and harry the town and you decide to smash the items in the House of the Sun. You should go into the House of the Sun and spend time pretending to do your damage and leave a note that describes what you have done. You can never actually break, damage or deface anything you find there; all those props belong to the players who have characters that are members of the House of the Sun.

A player may give another player permission to take an in-play item that belongs to them. For example, the Baron of Ultor has a banner in the inn. Another player wants his character to steal it and asks the Baron of Ultor out-of-game if he can take the actual banner. The player agrees figuring it will be easier to catch the thief if he has to run away with the banner. Even though he has permission, he should still be careful of the other player's property and not lose or damage the banner.

### Bringing an Item In-Game

Sometimes a player may wish to bring a piece of jewelry or other item in-game or make an item that was in-play, in-game. The player should be aware that once they do this, the item is now property of LAIRE and if someone takes it in-game, they may never get the item back.

The item can have any reasonable value that the player wants. They should take it to the Treasure Manager at the beginning of the Event and, after the Treasure Manager agrees to the in-game value, will engrave the item with its LAIRE number. **The player must pay the Treasure Manager 110% of the final in-game value of the item when it is engraved.**

Even though the item becomes LAIRE property, the player does not receive any Brownie Points for the donation.

Players cannot bring some things in-game. A player cannot bring in a weapon, armor, magic items, scrolls, alchemical items, gems etc. in this manner.

## Stealing

LAIRE is a game, and in that game there are those players who may wish their character to be a bit unsavory or of low moral character. In other words, they are thieves. This section will deal with the rules on how to take in-game items and what to do with them.

The player should have a firm grasp on the difference between in-game versus out-of-game versus in-play before they embark on their felonious career; for while thievery is permitted in-game, it is not tolerated out-of-game at all. **Put simply, do not take other players property, ever!** Taking another player's money, shoes, wallet, clothes, jewelry, duffle bag, or any other property is called stealing and it is a crime. The organization of LAIRE takes this very seriously and so should you.

**The following sections dealing with stealing and thievery always refers to in-game stealing, never the out-of-game criminal actions.**

## General Thievery

Any character can take some in-game item that does not belong to them. The character does not need a special skill to do so. The Rogue Basic Career and Master Thief Advanced Career have many skills that make this easier, but none are required.

There are three basic areas of thievery: Taking things you find around, taking things from a character, and taking things from a building. The later two will be discussed below.



Your character can only steal in-game items, but all in-game items fall into two categories: personal and LAIRE property. Personal in-game items are a character's weapon, shield, and their armor. Everything else – coins, gems, jewelry, scrolls, alchemy, magic items, etc. – are LAIRE property.

When your character steals a personal in-game item, you **must** take it to either the Armory or the Merchants Guild as soon as possible. Please remember that these items are another person's property and treat them with care. Any damage that occurs to them while in your possession is your responsibility to fix. These items belong to some other player and they are going to want them back. You may not go out-of-game while you are in possession of another player's personal out-of-game items. You cannot go to sleep, go NPC, or go and have a cigarette or perform any other out-of-game action until you have brought the items to the Armory or Merchants Guild.

The Armory and Merchants Guild have different advantages and disadvantages to selling things to them. Any weapons or armor the Armory buys, it can resell; they put it on their shelf to resell. So, if a character's sword is stolen and sold to the Armory, the sword you purchase back from them is the same one. Therefore, there is a chance to find out who stole the sword. The Merchants Guild, on the other hand, ships out much of the things they purchase. When a character's armor or weapon is sold to the Merchant's Guild, the equipment is gone and unrecoverable. You can still purchase a new weapon from them, or just reclaim your physical representation. The advantage of selling weapons and armor to the Armory is the price you will receive for the equipment. The Merchant's Guild gives a much lower price for these goods. This only applies to weapons and

armor that are a player's personal property. Items that are LAIRE property always remain in-game and if any guild purchases these goods, the items stay in-game. This is a necessary game mechanic that allows players to reclaim their property and the thieves a place to fence their hot goods with some measure of reliability.

Whatever LAIRE items your character acquires your character keeps. There is no need to sell it immediately.

## Searching a Character

Before any search can be done, the character must be unable to resist – unconscious, paralyzed, in their Death Count, etc. – or willing. Simply being bound with a *Bind* spell or being held for example, is not sufficient to allow a search. This does not mean a character cannot have their weapons or anything else removed from their hands when they are bound, however.

When a player wishes to search another player, they should position themselves next to them and say, "I search you." The character about to be rummaged has one of two responses: give over all their in-game items or request the searching character to describe their search by saying, "Describe your search." The third type of search requires the use of the Speed Search skill.

### Simple Search

When a player is informed they are being searched, one of their options is to agree to a simple search. The player must hand over all of their in-game items. Under no circumstances can a player withhold any of their in-game items. If the player thinks the searcher might miss something, then they have to ask for a complete search. If player has nothing to hand over and agrees to the simple search, they can simply respond, "You find nothing."

### Complete Search

Alternatively, a player can opt for a complete search. The player should tell the searcher, "Describe your search." The searcher then begins to describe what areas of the character's body they are searching. If the searcher looks at an area that has an in-game item, the player has to turn it over. For example, if the searcher says "I take off your glove and search your hand," the player should give over any rings or bracelets they have that are in-game.

This is what a complete search might look like. Ding has used the Waylay skill to render Elyssa unconscious. He tells her, "I search you." Elyssa opts for a complete search and says, "Describe your search."

**Ding:** "I look under your gloves."

**Elyssa:** "You find a ring." She takes off her glove and hands the ring to Ding.

**Ding:** "Okay, I'll check for anything around your neck."

**Elyssa:** "You don't find anything."

**Ding:** "What about that necklace?"

**Elyssa:** "That is only in-play."

**Ding:** "Okay, I'll check your pouches next."

**Elyssa:** "Which one?" Elyssa has a blue pouch behind her back that Ding cannot see, so she wants him to be specific.

**Ding:** “The two black ones, this one and this one,” he says as he points to the pouches, missing the one behind her back.

**Elyssa:** “The one on the right has out-of-game stuff in it. Here are the contents of the other pouch.” Elyssa takes out the silvers and coppers she has in her pouch along with a potion vial with the tag inside. Finally she hands over a gem that is magical. Along with the gem, she hands Ding the Magic Item Card from her out-of-game pouch.

**Ding:** He does not know what is magical and puts the card in his out-of-game pouch and continues, “Okay I pat down your legs and take off your boots.”

**Elyssa:** He begins to go through the motions of taking off her boots, it takes time to do this and Ding must wait. Once done with her left boot, she removes her right and hands him a scroll. “Here this is all you find.”

**Ding:** “Okay, anything else?”

**Elyssa:** “Not in the areas you described.”

After all this, Ding leaves and runs off to inspect his loot in secret, taking Elyssa’s weapons with him. A little while later, Elyssa’s friends find her and heal her. She checks over her stuff, and while is upset at being robbed, is grateful that the thief missed her one pouch and a magical hair pin in her hair. Elyssa and her friends set out to find the thief.

### **Speed Search**

If a character has the Speed Search skill, they can use that to search a character instead. The skill takes 10 seconds to use and will force the player to hand over all in-game items they have no matter how well hidden. If an item is attuned or hidden magically, Speed Search will fail to give the searcher these items. In the case of an attuned item, the searcher will know it is worth something, but is attuned.

For a full description of how the Speed Search skill works, see the skill’s description in Chapter 5.

### **Searching a Room or Cabin**

**The first thing a player has to do before searching the place where other characters sleep, or a guild – be it a cabin, inn room, tent, lean-to, etc – is to get a Rogue Marshal.** No character can enter the cabin, etc. with the intent to steal without a Rogue Marshal. Also, the Rogue Marshal must be out-of-game and not involved with the in-game planning or executing of the theft.

The Rogue Marshal will check out the cabin and read any out-of-game marshal notes for the building before the theft begins and stay

to the side while the characters do the deed. During the theft, the marshal may answer questions about what is in-game and what is out-of-game and interject when needed describing traps or other in-game effects the thieving characters may encounter.

The characters may only search in-game boxes, bags, cabinets, etc. while they are looting a cabin. The area under a bed is always out-of-game. Also closets, dressers, and other furniture in the room may be designated as out-of-game with a sign indicating such.

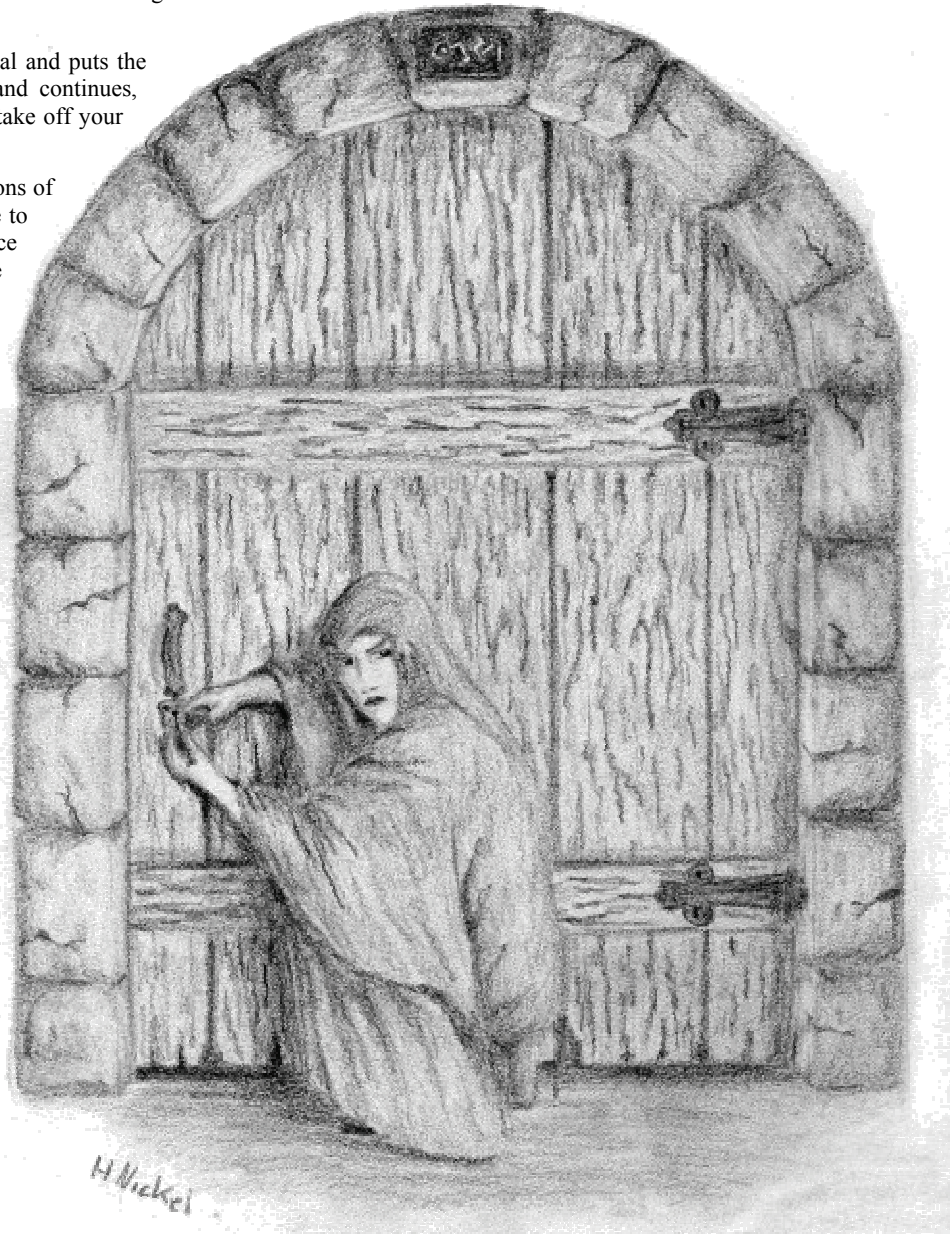

If you take any items that require physical representations once they are removed from their place of storage, then you must provide a physical representation before that item can be removed from the room. Yes, that means if you do not have one, then you can not steal the item.

Read the sections on in-game, in-play and out-of-game items and know it well before you search a cabin.



## Hiding In-Game Items

You are required to account for all of your in-game items at every Event. If you have the item in-game and hide it in-game, then it is fair game for anyone who finds it. You may leave your in-game items at your in-game home, however, you must inform a Plot Marshal and if you wish to retrieve the items, you have to get permission from the Plot Marshal. Sometimes, the items may either be stolen or your home may become unreachable due to in-game events. Finally, any item left at home is either inaccessible to the character or you have to get permission from a Plot Marshal to go and retrieve your item. If you are caught retrieving your items from your car or home without a Plot Marshal's permission, you will receive a rules violation.

As long as the in-game item is hidden in an in-game location, the player may hide their treasures anywhere they want; for example, under a log, beneath the steps to their cabin, in a field, etc. Your duffel bag under your bed is not an in-game location. Remember that at the end of the Event the items need to be recovered, and the player should make sure they remember where they hid it, for if the player forgets, their character has lost the items in-game. Similarly, if the player returns to the hiding spot and does not find their character's items, it is lost in-game.

A character may attempt to hide something on their person, but this does not guarantee they will not lose it if searched. Remember that when a character is searched, they have two choices: a Simple Search and a Complete Search. A player must hand over all their character's items if they agree to a Simple Search and if the searching character calls the location where the item is hidden, the player must hand it over. LAIRE does not allow hidden pockets or similar things that obscure items from searches.

## Securing Your Cabin – Locks and Traps

Of course, a character can hide their items in their cabin and use in-game locks and traps with the use of the appropriate skill. Anyone can use a LAIRE approved lock to secure trunks and boxes or even a door. You may only use LAIRE approved locks. As long as you have the key for your lock, you can open it. **You can never out-of-game actually lock a door, ever, with any lock.**

A lock with no item number on it is a normal lock that can be easily shattered or broken with 10 points of damage. LAIRE locks with an item number on it usually indicates it is unshatterable, or maybe even magical and will be accompanied by a tag indicating its in-game properties.

Characters with the Set Trap skill can booby trap their treasures and cabin. See the Set Trap skill for a description of how this skill works. Remember only a character with the Disarm Trap skill can disarm a trap, but anyone can spot one.

## While You are Out-of-Game

If a player goes out-of-game at an Event for some reason, they may be required to leave some of their possessions in-game. As a general rule, a character's weapons, armor, shield, money, gems, scrolls, potions, or magic items go out-of-game with the character.

However, if a character has any important items, the character may be required to leave them in-game when they go out-of-game. For example, if a character has stolen the Duke's sword and there are teams of adventurers searching for it, the player cannot take the sword out-of-game for any reason. If the player has to go out-of-

game, they should first talk to a Plot Marshal to discuss where the item should be left.

## A Final Word on Stealing

If the rules on in-game stealing are abused or ignored, the Executive Board of LAIRE can, will, and has done so in the past, suspend all in-game stealing or even stop the game until the situation is rectified. Do not ruin an entire event for everyone by ignoring these rules. Be a responsible player.

Remember to get a Rogue Marshal before you enter the sleeping area of another character to steal.

## Event Cycle and Timeline

The following timeline is given to give a player the needed information on what is expected of them before, during and after an Event.

- 1) The week after an Event you should go on-line and pre-register for the next Event if you plan on attending. If, after pre-registering, you can not make the Event, you are required to contact Logistics by Wednesday night before the Event to cancel your registration. **If you fail to do so, you are charged \$5.00 and 1 Play Credit and will receive no Awarded Build Points.**
- 2) Before the Event, you should check your weapons and make sure they are in good repair and will pass at the Event. Clean all your clothes and straighten and fix your LAIRE equipment.
- 3) The week before the Event, you can check the web site to get your room assignment. **Any player that travels more than 350 miles to attend an event is not required to NPC or perform any other type of 5 hour duty shift.** This is for players who live that far away only.
- 4) Pack up your LAIRE stuff and make sure you have the following:
  - a) White Headband
  - b) Flashlight
  - c) Pen
  - d) Toiletries
  - e) Costume, including extra clothing, weather appropriate clothing, shoes, and extra socks
  - f) Weapons, armor, shield, etc.
  - g) In-game items
  - h) Sleeping bag, pillow, blanket, etc.
- 5) When you arrive at the Event, go to Logistics and verify your sleep assignment is the same. Logistics will be open at 7:00pm on Friday night.
  - a) After you drop your stuff off, get into costume and bring your weapons and white headband to Logistics. If you are NPC'ing Friday night, you do not have to have your costume with you.
  - b) Before going to Logistics, get your weapons and spell packets checked. Even if you are NPC'ing Friday night, you need to get your weapons checked.
  - c) Go through check-in at Logistics. You will get your character's card and pay for the Event at Finance. Even if you are NPC'ing the whole Event, you still need to check in at Logistics.



- 6) After you have checked in, you should stay near the main building for Opening Ceremonies, which starts promptly at 8:30pm. The game starts (lay-on) at 9:00pm on Friday night.
- 7) PLAY! And have fun, but do not forget to do your work assignment. Be on time and ready to go for your NPC shift.
- 8) The Event will end on Sunday (or Monday for a 4-day Event) about 2½ hours before sunset. The time will be announced at Opening Ceremonies. After the game is called, everyone should attend Closing Ceremonies. At Closing Ceremonies you will receive your Camp Cleanup Assignment. Everyone also has a Sleeping Site Cleanup Assignment.
- 9) After both your cleanup assignments are completed, you may check out at Logistics.
- 10) Then the whole cycle begins again with step 1.

Pages are primarily used to exchange in-game messages between characters. They are allowed to roleplay, speak in-game, and be spoken to. However, they may not use any skills or items, nor may they make physical contact with players for any in-game reason. To kill a Page, stand within 10 feet of the Page, point a weapon at them and say, "I kill you."

Anyone 13 or younger must be accompanied at all times by a parent or legal guardian, or a specified adult with parental consent. The supervising adult must remain out-of-game.

## Pages

To actively participate in LAIRE, a player must be fourteen years old or older. However, there is a role available to those too young to play in the entire game: the role of Page. Pages are in costume, but they wear safety orange colored non-combat headbands to indicate their non-combat status. Anyone may inquire with the Plot Committee if there are positions available as a page.





# Chapter 8: Midlantia and Avalon...



About Avalon...

“...and from south of the hills there will arise a human, with the power to slay the dark queen in her lair. Thus is her destiny written, and it shall not be unwrote...”

~ An Unknown Loreli

The game of LAIRE is set in the Duchy of Avalon, in the world of Midlantia. This chapter contains in-game information that every character may know. The player can decide for themselves what pieces of information their character knows; for example, if your character is an ignorant barbarian, they may not know the population of each town in Medici.

This chapter describes the game world as of 1108 Post Imperial (2008 in real world time). However, the situation in Avalon is sure to have changed after this is written. After all, the point of LAIRE is to live through a story, so be prepared for some surprises.

## The Duchy of Avalon

**Motto:** *Terra animus est Avalonorum*  
The soul of Avalon is Avalonians

Located between the Bay of Lüne and the Mistwood Forest in a region of Midlantia called the Southern Reaches, the Duchy of Avalon consists of two counties and a total of five baronies. In the County of Avalon High there is The Dale and Medici and in the County of Avalon Low there are the Baronies of Islewatch, Eastguard, and Ultor.



### The City of Avalon

The city proper of Avalon is located at the border of the Dale, Islewatch, and Eastguard on the northern bank of the Psynian River. It is here that the Ducal Seat is located. The city is under the jurisdiction of the Duke's Chancellor, while the surrounding lands are under the care of the various nobles of the Duchy. See "A Walk Through Avalon" for specific information about the city of Avalon and its inhabitants.

## The County of Avalon High

Comprising the baronies of The Dale and Medici, the County of Avalon High governs the northern half of the duchy. The Dale is the seat of the county.

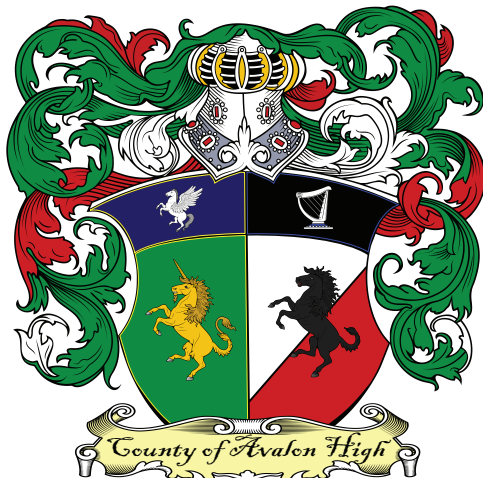

### The Dale

**Motto:** *Perseverantia palma*  
By perseverance one gains the palms (prosperity)

The Barony of the Dale is mostly made up of people who are farmers or who work the Psynian River. The Dale is the bread basket of the Duchy, supplying the greatest amount of food for the Duchy. This is not to say that The Dale does not have its share of craftsman making many of the required finished goods the people of The Dale need.

The most notable city is the fortress of Greenstone, built by Baron Roget of the Dale at the time of border disputes with the Duchy of Barconia. The fortress was named for the color of its stonework. The Psynian River carries a brisk trade from Medici to the city of Avalon. The Dalemen are known for their animosity towards Barconians.

In recent history, some displaced Halflings who were fleeing the chaos during the fall of Nymidia came to the Duchy of Avalon seeking refuge. The Baron Derek Ironheart offered them a new home in the Dale and New Gleneden was founded.

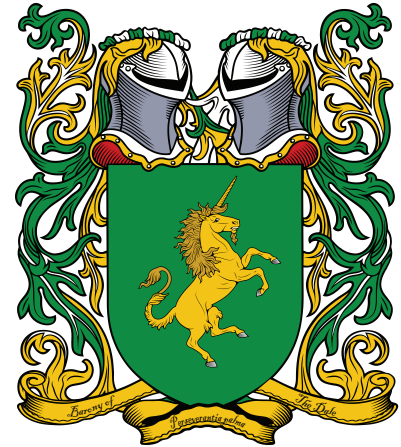

### Medici

**Motto:** *Bello ac pace paratus*  
In war and peace prepared

The Barony of Medici occupies the northern portion of Avalon, from the Darkwood to the midpoint of the Black Hills. All manner of people live in the Barony, and for the most part, they live in harmony. Medici has the largest standing army of any barony in Avalon and is responsible for the defense of the northern border. With incursions from the Darkwood, Barconian invasions, and all sorts of trouble from the lands of the Nymidian Empire, the soldiers of Medici have constant need to hone their skills.

Medici has vast forested areas and a good supply of stone, and exports the former to many places. However, due to the large population, large standing army, and lack of arable lands, Medici has to import large quantities of food – usually from The Dale.

The Tower Citadel stood for many years, and was abandoned due to a successful Trollish uprising. Later, the tower was destroyed when a group of adventures from Avalon freed a demon trapped in the depths of the tower. It is rumored that the Hierarch Balphagor created his





creatures in a cavern deep underground under the tower. The once great fortress sits in a pool of magma, and the area around the tower is inaccessible to most people and creatures. The glowing red light from the lake of fire creates an evil glow on the mountains and sky around it at night.

## The County of Avalon Low

Comprising the baronies of Islewatch, Eastguard, and Ultor, the County of Avalon Low governs the southern half of the duchy. Islewatch is the seat of the county.

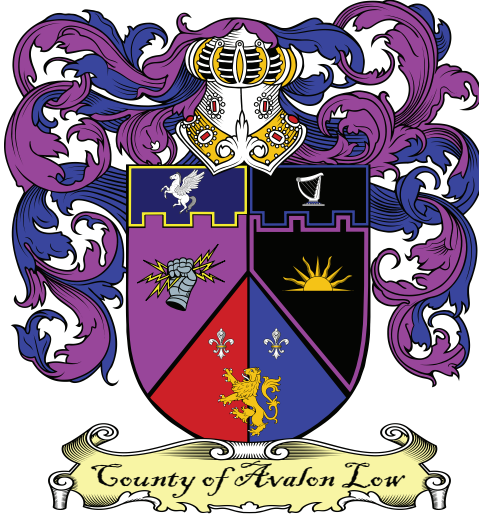

### Islewatch

**Motto:** *Forti et fideli nihil difficile*

To the brave and faithful man, nothing is difficult

The Barony of Islewatch covers the entire southern portion of Avalon. It is ruled by the Baron of Islewatch from a castle high on the cliffs over the Bay of Lûne. The castles of Islewatch High and Islewatch Low are charged with guarding the Duchy from any waterborne invaders.

Islewatch produces the best wines in the Duchy, but they are rare and often quite expensive. The barony has a diversified but limited set of resources and a good number of craftsman and tradesman. The long and easily defended coast makes the ports of Islewatch very desirable and they are busy with sea born trade. All of this makes Islewatch very self-sufficient.

The most notable feature of Islewatch is the Great Cliffs, which are said to house many caves and caverns. These cliffs were once a spot frequently visited by the Reaver Pirates in the past, and stories tell of drakes flying into and out of the high caves.



### Eastguard

**Motto:** *Faber quisque fortunae suae*

Each man (is) the maker of his own fortune

The Barony of Eastguard sits in the eastern portion of the duchy and has access to many good mining locations in the Black Hills, making stone and metals their chief export. The lands of Coventry and the home of the Dwarven people lie to the north and profitable trade comes through Eastguard from these lands. The craftsmen of Eastguard are renowned throughout the duchy. The hard, rocky soil and sparse wooded areas make it difficult for Eastguard to meet its needs and they often have to import these commodities from elsewhere.

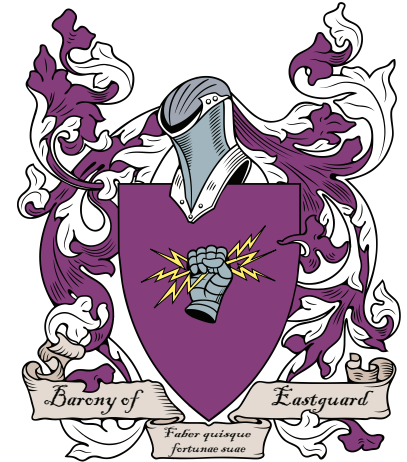

A number of ruins have been discovered in Eastguard and have been a source of many adventures over the years. One most notable one has been the ruins outside Altic. A great number of dark creatures were found down in those ruins and a race of cursed Elves called Pantherghast Elves. These cursed elves get their name from the elven noble – Lord Pantherghast – who made a deal with the Hierarch Bazmodeous for great power. Bazmodeous in exchange cursed Pantherghast and his issue. It is said that the blood of a Pantherghast is poisonous to all elves and they are wholly evil. The current whereabouts of the Pantherghasts is not known.

### Ultor

**Motto:** *Incepta persequor*

I persevere in what I undertake

Ultor is the newest of all the Avalonian baronies. Created circa 1100PI by Sir Bron who was named Baron of Ultor when the territory was confirmed a barony by Duke Sir Molin.

Located south of the Barrowdowns and with the ocean to the east and the Greenbriar River to the south and west, this barony is cut off from any easy access to the rest of Avalon. The main port bustles with trade, as rare foods and spices from the interior find their way to the rest of Avalon and Midlantia. Ultor lacks stone and forests and spends much of its trade wealth on importing these supplies.

The land is rife with ruins and unexplored places and many adventurers travel there, seeking the next great cache of ancient secrets and coin.

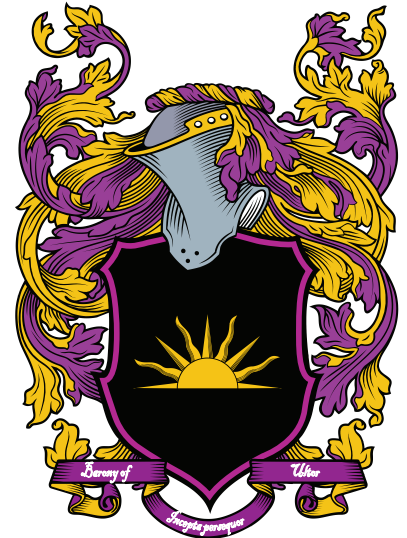



## The History of Avalon

The Nymidian Empire has been the dominant power in this region of the world of Midlantia for what was believed to be before recorded history. At the core of the Empire itself was the aloof True Nymidian people, who considered themselves superior to all others. While their numbers were small, they had superior magical talent and could easily bend others to their will. Acting in harmony with their armies, they came to be in control of the vast majority of Midlantia. From the Northern Ice to the Plains of Gehenna, from the Great Eastern Water to the Wolfskael Mountains, the Imperial Standard flew.

The Empire expanded and contracted, made war and had peace, for over 4000 years. There were many important events during these years, but only two will be mentioned here: the colonization of the area that came to be known as Avalon, and the Great Catastrophe that shook the Empire.

### Ancient History

“The Nymidian Empire is the birth of civilization on Midlantia,” was believed for a great long time to be true, but recent discoveries have proved this statement false. Recently, adventures and scholars have found lost documents from a time that predates Nymidia. Even more astounding, people have met and spoken to creatures and beings that predate even this ancient time. So it would seem the world of Midlantia is much older than any modern scholar believed or understood it to be.

Very little is known from this ancient time. It is now commonly accepted that there was an empire in the lands surrounding Avalon that was as vast as, if not more grand than, the Nymidian Empire at its height. This empire was called the Carthidian Empire, and the lands now known as Nymidia and Avalon were within its domain.

It has been learned that the region known as Psynia rebelled against a corrupt and decadent ruler of Carthidia, which eventually led to the destruction of the Carthidian Empire and even the very land it once called its domain. Eventually, Psynia became the Nymidian Empire and after a dark time of war, strife, hardship, and loss, history was once again recorded.



## The Exploration of the Southern Reaches

In the year 1221BF (Before the Fall), the Emperor of Nymidia sent forth a proclamation to his subjects. This document annexed the land south of the Black Hills as part of the Empire of Nymidia. It was his Imperial wish that some of the peoples of the Nymidian Empire would move south of these hills and explore the land further, settling therein and becoming a viable part of the Empire. A forest of trees had been discovered just at the western head of the hills, and it was named Mistwood, for the mist that sometimes enveloped the trees at dawn. Within the Forest there lived a goodly number of Elves who had little contact with those who were coming from the North as long as they did not disturb the harmony of the Forest. Between the mountains and the Forest, a narrow pass was discovered. With this, exploration began into the area that had become known as the Southern Reaches. Trailblazers moved farther south and began to spread out to both the east and west. At the time the Bay of Lûne was discovered, many farms had developed in the dale lands to the west, near the banks of the Green River. In the year of 1317BF, a community of Dwarven miners moved from the Wolfskael Mountains down into the Black Hills. They were eager to have a market for their iron goods, and trade began to flow. The town of Avalon was then formed on the banks of the Psynian River.

As exploration progressed outward from the Mistwood, Avalon, now grown into a walled town, turned to the sea to help feed its growing number of occupants. The idea of a fishing colony was suggested, to be located amongst the islands in the Bay of Lûne. When word of this reached the Wood Elves, several shook off their fear of the people of Avalon and approached the town. They told the leaders of the town that the islands were a bad place, and that great evil lived out on the bay. The town leaders laughed at this, and put it off as a superstition of the timid elves, who rarely ventured out of their forest home. Patrick Novius, a former sword-for-hire, took sixty people to one of the islands and formed a colony of fishers and traders. But word and goods from the Isle of Novia soon stopped. A party of adventurers was dispatched to the island to investigate the silence, and they were mystified to find the entire island deserted. Not a trace of the colony could be found, and the only clue left was a large swath cut in the beach.

The family DuRhône, rich merchants from the north, moved into an ancient castle high atop the Great Cliffs overlooking the Bay of Lûne. The Emperor assigned them the task of maintaining a vigilant watch for any threat from the sea. The first Count DuRhône, Eldin, established the keeps of Islewatch High and Low for this purpose. Count Eldin DuRhône eventually became the first High Sorcerer of Avalon.

During the next century, many more humans and elves made their way into County Avalon. Farms produced quantities of foodstuffs for export, the Black Hills yielded their iron ore, and there were rumors of rich finds in early efforts to mine deeper into the bowels of the mountains. The trolls were ever-present and restless, but the military presence in the Medici area kept them under control.

## The Trollish Uprising



In winter of 1492BF, the Emperor proclaimed a need to consolidate the leadership in the new southern provinces, and so ordered the peoples of the area to join together into the Ducal State of Avalon. Several nights after the official proclamation was made, the nobility of Avalon had a grand ball in the manor house in Avalon proper. Several hundred guests danced and dined in merriment, but unbeknownst to them a great evil was stirring. The trolls, driven by a dark presence,

came boiling out of their underground caverns in rebellion. With them came orcs, goblins, and other darkly sinister creatures, led by a demon from deep within the earth. They struck without warning, using a dark magic to come upon Avalon without a sound. In an instant, the grand ball was a *danse macabre*. Revelers were cut down in swaths, and the Duke himself was slain by a single blow from the dark demon.

Within the week, the trollish hordes had overrun almost all the Duchy. In the Barony of Eastguard whole cities were enslaved. The remaining functional units of the Baron's garrisons were holed up within the halls of Clan Blackhill, under siege in the city of Dwarvenholm. Far into the Mistwood, the ducal army hid with aid from the elves, temporarily safe from the rampaging monsters that ran amok over the Duchy. Only the eastern dale lands were free from the yoke of the trollish bands, for the trolls had not yet come to the banks of the Green River. Heavy winter storms hindered any aid the Empire sent in support of the stricken Duchy. Many died that winter from starvation and disease, as well as from misuse by the evil occupants.

Aided by the discovery of a cache of eldritch scrolls, the Emperor attempted to contact the surviving Avalonians. A crumbling parchment told of a network of natural caverns and tunnels originating in the ruins of an ancient city that once stood on the plains of Eastguard. These subterranean passages had outlets in both the Black Hills and the Mistwood. Four separate parties of adventurers were dispatched in an attempt to find the tunnels and get word to the survivors.

Also revealed in these scrolls was the existence of the Loreli, a race of prophets and seers, and their homeland on the Nyte Skye Isles. When the Emperor compared some of their prophecy to history, he found startling parallels. The Emperor gathered the few Loreli who were abroad to the Crystal City, and he forced them to serve the Imperial throne. Those who would not submit were put to the sword.

In the spring of 1493BF, the Emperor's Imperial Host marched down through the pass in an effort to relieve the besieged peoples. Fiercely they fought on the plains of the dale lands, where some of the trolls had been caught unawares. As the days of battle progressed into weeks, more and more of the trolls came back to the west. The men, elves, and dwarves of Avalon, who had been reached by two of the four adventuring groups, rallied and came forth to attack the horde from the rear. With them was a group of Dark Elves, whose underground city of had been discovered in the caverns far underground by one of the groups. Finally, the might of Nymidia

prevailed. The trolls and their allies were driven back into the hills. This, however, was not enough and the trolls were pursued. But the magic of the demon was too great for a victory by the people of Nymidia, and a stalemate ensued. The Emperor sent for aid, this time in the form of his personal bard, Oliver, who was reputed to be a mighty Spell Singer.

Oliver went into the hills at the head of the host, where he contested with the demon in an awesome display of magic and physical prowess. After days, Oliver succeeded in banishing the demon back into the underground world that it came from. The combined armies then attacked and were able to drive the trollish hordes into the darkness, wherein they were sealed.

For his actions in besting the demon and the trollish swarm, Oliver was named the new Duke of Avalon in 1493BF. He took the surname Descante, and thus the line of Oliver Descante was born.

## The Building of the Tower Mountain Citadel

The first act of Duke Oliver of Avalon was to order the construction of the Tower Mountain Citadel. Many Dwarven engineers were transplanted from the Wolfskael Mountains to the Tower Mountains for this task. This massive citadel, carved from the living rock of Tower Mountain, was enchanted to keep in the trollish infestation trapped in their underground caverns. This did not completely entomb the trolls, but limited the number that could escape. The garrison in the citadel was able to contain those few who reached the surface.

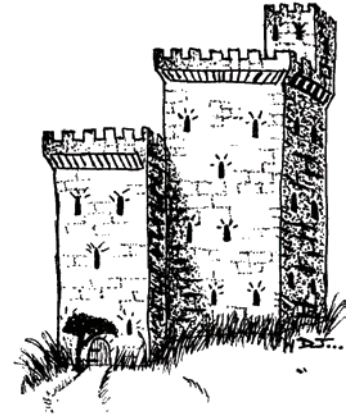

As the years of construction went on, the dwarves were delighted to unearth a rich vein of Mithril. More dwarves came out of the Tower Mountains at word of this discovery. Soon, several mines appeared in the Tower Mountains, with grim-faced dwarves guarding them from the ever-present trolls.

In the year 1513BF, the Duke decided that the Dale lands in the east should have more representation at his court and formed a new Barony. The ranger who led the expedition through the tunnels of the ruined city to take word to the besieged city of Dwarvenholm, Jon Blyth, was then titled Baron of the Dale.

With Tower Mount complete, Duke Oliver saw no further need for the people who lived in Medici to suffer the effects of a military district, so he created the Barony of Medici in its stead. Sir Russel Galtus, commander of the Medici occupational force, was named Baron of Medici.

There was peace in Avalon for several years, for Evil's focus had moved north of the duchy. Many adventurers moved to the Wolfskael Mountains to wrest new land from both goblin and barbarian alike. In the year 1520BF, Avalonian regular troops were called up by the Emperor against the goblin menace in Gleneden.



## The Catastrophe

Over the next century, the Empire's control over its outer provinces grew weak. Rebellion became commonplace. Ambush, murder, and espionage had also become common across the Empire. In 1599BF, Emperor Vardak dispatched the Midlantian Guard to Briton with orders to quell the rebellion by eliminating the majority of the populace. The Guard did as they were ordered. Two entire cities, thousands of people, were put to the sword. Lord Brigadier General Richard Llewellyn of the Imperial Armies, resigned his commission. The Emperor refused the resignation. In a fit of rage, Llewellyn slew the Emperor. The entire Empire ignited in rebellion and civil war. This monumental upheaval, known as the Great Catastrophe, lasted for a thousand years.

No written records were kept of the Great Catastrophe. The tales told of that time vary. The inner core of the Empire remained intact, although the Crystal City was sacked several times. The majority of the outer provinces gained and lost their freedom several times. Eventually, the wars subsided and the borders settled to where they stand today, with a few exceptions.

## Conflict in Medici and the Dale

In the thousand years since the start of the Catastrophe, peace had descended upon Avalon, and the Duchy flourished. But suddenly, in the year 1075PI (Post Imperial, After the Catastrophe), both Duke Jared of Avalon and Baron Ignatious Galtus of Medici were killed by an enchanted monster. Mandros Galtus, the third son of the Baron, quietly left for Barconia under suspicion of practicing dark ritual magic. Jared's son Powell succeeded his father to the Dukedom at the age of two and a half. His mother Linydel (the Duchess of Avalon) became the first woman to rule in Avalon until Powell came into his majority. The other Galtus sons, Morgan and Arthur, vowed to track down the monster responsible; in this task they were aided by some veteran adventurers.

The monster, believed to be a fiery elemental creature of some kind, was tracked to the banks of the Psynian River in Medici. Here, at a small wooden bridge, the creature killed Arthur and cast his broken body aside. Another member of the hunting group, Philip di Medici, ran out onto the now flaming bridge to combat the evil thing alongside his lifelong friend, Morgan. Eventually the bridge burned through, casting both the elemental and Morgan into the river to be swept away. Neither body was ever found. A great stone bridge was built on the site of the battle, and the town around it became Medici's Bridge. Duchess Linydel named Philip di Medici to be Baron in Medici, since the Galtus Line had no successor.

About ten years later, the Barconians began to covet the rich dale lands across the Green River. In 1088PI, Barconian soldiers crossed the river into the Dale along with several tribes of Outlanders, beginning the War of the Dale. It was a short but vicious conflict, with many casualties. The Baron of the Dale immediately constructed keeps along the Green River. The capital was renamed Greenstone, for the color of the immense blocks of stone that were used to reinforce the tower, making it into one of the most massive castles in the Empire. While on a recreational hunting expedition in the Tower Mountains, Baron Roget A'Vaughn was killed in an accident chasing a great white ram. His eldest son, Dinayr, became Baron of the Dale in 1089.

## The Rise of the Cult

During this decade, Avalon was seeing the rise of a foul and secretive group. Composed of necromancers and other villainous types, the Cult of the Cryptic Shade, named after their patron Hierarch Azeroth, the Cryptic Shade, began operating mostly in the Barony of Medici. Their far reaching influence and unspeakable acts were soon reported all over Avalon. More and more evidence linked them to various ghastly deeds. It was rumored that they had built a city hidden in the Darkwood, but an expedition to the wood could find no such inhabitants.

In the year 1090 PI Lady Grace Nordenn, the wife of Baron Frederick Nordenn, was murdered in her bed. The blade that killed her was left between her shoulder blades, and on the hilt was the sign of the Cult. Swearing vengeance, the Baron took his personal retainers and entered the Darkwood to see justice done. None were ever seen again. Several adventuring parties have since gone in to explore the woods, but those who do return are unable to speak of the experience therein, even with magical prodding. Frederick's only son, Bryan who had to be restrained from accompanying his father, became Baron of Eastguard.

In this same year of 1090 PI, the Highlands were overrun by the Bainite Army.

The next year there were a variety of crimes that bore the markings of the Cult of the Cryptic Shade. Murder, theft, and the magical summonings of a multitude of evil creatures eventually attracted the attention of the Duke, who called on the people to take up arms and combat the evil where it appeared. The garrisons from nearby cities responded when they could, but the incidents were too widespread for them to be effective. The citizens were much closer to the incidents when they occurred. Adventurers again filtered into the area when one Cult member, a mage, was killed and found to be carrying magical treasures.



## The Fall of the Tower Mountain Citadel

The majority of the "disturbances" seemed to be in the Medici area. In January of 1091PI, the Duke made it known that he would make a trip to the Tower Mountain Citadel in the spring to consult with Baron di Medici on the subject. It was while the Duke was in conference with Baron di Medici that the terrible tragedy occurred. There was a clap of thunder, and the very foundations of the Tower shook.

The Baron ran out, calling on the guards to see to the safety of the Duke as he rallied the garrison to address whatever this threat was. As the Duke raced down the stairs, one of the guards raised high a darkly enchanted dagger and plunged it into the unprotected back of Duke Powell. The Duke fell, and as the guards attempted to subdue the renegade he muttered an eldritch incantation and vanished in a puff of smoke. Just as he disappeared, a thunderous cracking could be heard and trolls began to boil up out of fissures that appeared in the ground.

The garrison was taken completely by surprise, and those who were not routed from the Tower were slaughtered. Fire broke out in an upper room, and soon flames belched out of several windows, with men being defenestrated by some unknown force. The Baron had managed to escape, and rallied the survivors outside the citadel's walls. Messengers were sent to nearby towns with warnings.

The remainder of the garrison was prepared to flee when an unusually large troll appeared at a Tower window, holding the severely wounded Duke in one hand. He called a challenge to the Baron below, who dismounted to rush back in to his Duke's aid. Before he went two steps, however, several arrows struck him with lethal accuracy and immediately knocked him to the ground.

Alaric Dragonhart, a young noble from Gleneden newly attached to the Tower Garrison, ran back into the flaming fortress to attend to the Duke. There were bright flashes, and explosions were heard from inside the Citadel. A surge of fiery magic blew the main gate out off its hinges, injuring many of the soldiers outside. Out of the smoke came Alaric Dragonhart, carrying the now limp Duke in his arms. He lay the nobleman down, and the guards made a protective ring around them. As trolls assailed them, the dying Duke named Alaric his heir in front of witnesses. Powell's spirit sailed away into the night and was never seen again.

With a great shout that echoed through the mountains, the new Duke turned to assist the sorely wounded Baron in the battle against the trolls. Those monsters that remained seemed to cower in fear of the pair. No one knew what had been done in the Tower, be it skill of the magical or martial sort. The trolls backed off slightly, and Baron di Medici took the initiative to call an orderly retreat to the town of Messina. He continued on to Avalon, bearing the body of the slain Duke.

## The Brief Reign of Duke Dragonhart

The summer of 1092PI saw a yet another menace arise. The demon that drove the trolls to attack Avalon thousands of years prior, who had been contained by the Bard Oliver, was somehow freed.

Alaric wore the Ducal Signet for only a few years. Possessed by a demon early in his reign, he suffered terribly and his abilities waned. In 1092PI the combined Outlander tribes, numbering in the tens of thousands, attacked the civilized Southern Reaches. They were blunted in the Battle of the Barrowdowns early in the winter of that year. The distraught Duke, absent from the battle, took to his castle and was never seen in public again.

In the summer of 1093PI, in a battle that destroyed the Ducal Castle, Alaric Dragonhart was killed by a dragon that seemed to be attracted or directed to Avalon. In a great ritual performed by the High Sorceress, Countess DuRhône and the High Mage Winston Waterston, Alaric's spirit was briefly called back from the netherworld. The Duke's shade named Zakk Yarnspinner, a merchant of Avalon, as the rightful heir to the Ducal seat.

## The War with the Hierarchs

Relative peace settled over Avalon for a year, but things were not all as they seemed. The beginning of the summer of 1094PI saw stirrings, dark portents and whispers in the night that told of dark times to come. Reports of trolls amassing in the mountains came to the nobles of Avalon. Before anything could be done about this, betrayal came to Avalon in the form of a man named Desotti, a member of the Merchant's Guild who was also a new father of two. Soon after his children were born, he took one from the child's

mother and in the cover of night, in the deep of the forest, sacrificed the child to the Dark Lord and for his offering he demanded but one thing: the destruction of Avalon. Nothing happened, his sacrifice seemed to have gone unanswered. Sadly, his act had not gone unnoticed and it set into motion a chain of events that would not end for many years.

A moon later, after the wedding ceremony of Sir Molin Hearst and his wife, the Duke called an assembly of commoners and nobles alike for a trial. The Countess Blaize DuRhône had learned of Dosotti's vile act; his trial was swift and he was found guilty. Though offered many times to speak, he refused to defend or reveal the reasons for his actions. Countess Blaize carried out his sentence, killing him and destroying his soul forever for the vile acts he had committed.

While many breathed a sigh of relief, the evil of his deeds had been wrought and a dark storm was gathering that most could not see. A moon later, the gates to Hell cracked open and the Dark Lord of the Abyss, Bazmodeous, with his dark powers restored, stepped forth, and gathered his trolls to him and marched on Avalon. Those that stood in the city that day witnessed the greatest heroes the land had, including the Duke Swansong and Countess Blaize, reduced to mere tiny metal statues and imprisoned in a model of the Ducal Keep to be tormented by Bazmodeous. The town fell to the might of the Lord of the Hierarchs, then the Duchy. Hordes of demons led by the other eight great Hierarchs swiftly conquered Avalon.

By the end of the summer of 1094PI, Avalon was ruled by Bazmodeous and the Council of Nine. The heroes that remained fled to the woods and hid. Others, however, saw what the traitor did and knew what would come of it, and came to help. Countess Blaize's brother Eldrick DuRhône and the Lorelei Anhock came to help. Help came from another place; hours before Bazmodeous' exodus from hell, Eldin DuRhône himself came to Avalon and spirited away the Paladins of Avalon. They were taught new skills and brought back to Avalon to help drive out the Hierarchs a moon later, at Avalon's hour of greatest need.

Besides freeing their leaders from the clutches of Bazmodeous and driving the Nine back into hell, the Heroes of Avalon had one more thing to worry about. The Tree of Life was dying. When Bazmodeous tore his way through the veil and the Nine came through, the Tree of Life was mortally wounded.

By the end of that summer, the heroes healed the Tree of Life, broke the magical prison freeing the heroes within, and drove off Bazmodeous, shedding the yoke the Hierarchs placed on the people of Avalon.

## The Elven War and Rise of Azeroth

Order was restored to Avalon but the threat of the Nine lingered as the Hierarchs retreated from the forefront and plotted their next move. Avalon did not sit idle, and with the help of a Lorelei, found a ritual to imprison them in ice. The Host of Avalonian Heroes fought their way to the heart of the Darkwood, where the Elven Grove sat, for it was only here that the ritual could be cast. Their mission was two-fold, first to trap what Hierarchs they could and second, to act as a diversion while a second group moved to a swamp, where a cure was to be made to heal the wasting disease that the Duke, the Countess Blaize, and the Lorelei Gabriel Stone suffered from as a result of their time imprisoned by Bazmodeous.

When the battle was done, Bazmodeous, Arachnia, and Bain were trapped in the ritual of ice that was cast. Avalon dealt a mighty blow to their enemies, but there was a yet unknown price to be paid. The Lorelei was not who he claimed to be, instead he was the Cryptic





Shade, Azeroth shapechanged to fool the heroes into not only eliminating some of his rivals, but to bring an end to the Elves of Midlantia. The Grove was linked to the Elves and its destruction heralded an end to their races.

After the Grove was frozen, the Elves of Mistwood began to grow sick and the very old and very young died. No Elves bore any young nor could they conceive any new children. They faced extinction. War broke out between the people of Avalon and the Mistwood in October of 1094PI. While the Elven Queen lay dying, the elf known only as The Hunter led many embittered elves to Avalon and waged war. Many battles with the Elven Hunters and Slayers were fought throughout Avalon.

Another threat came from the Elven wood in the form of a child. The last Elven child born alive after the Grove was encased in ice was an abomination that bore the one desire of vengeance. The feral and unstoppable creature came to the Avalonian host in November, while they were in Barconia dealing with a growing goblin menace. The abomination grew in days and began slaughtering the Avalonian Heroes. Eventually, Duke Swansong cornered the creature and did single combat with it. Even the Duke was not a match for the creature's power and, in a last act of desperation, broke the legendary Dragon Sword and killed the abomination with the freed magical energies.

The town cheered and the day seemed won, but the Hunter was waiting and fired an arrow that instantly and irrevocably slew Avalon's Duke. Even all the powers of Countess Blaize could not bring the fallen Duke back.

Countess Blaize took the title of Duchess and ordered her people to find a way to restore the Grove. Early in the year 1095PI, during one of the coldest days Avalon had ever seen, the town came under assault not only from Elven war parties but the Hierarch Molizar, Lord of Vampires and legions of undead. Many heroes fell that moon, even the Baron Cedric Nordenn died at the hands of the Hunter, much in the same way as Duke Yarnspinner.

After long and grueling battles with Molizar and all his children whom he summoned to do battle for him, Avalon defeated the Lord

of Vampires and slew him utterly and completely. During the same cold month, a group of Avalonian adventurers had discovered a ritual to summon the Cryptic Shade and force him to tell them how to fix the Grove. Among the snow shrouded woods, and with the Host of Heroes assembled, the ritual was cast and Azeroth appeared.

With the answer in hand and the cold weather over, Avalon once more marched into Darkwood and healed the Elven Grove, freeing the Hierarchs in the process. Weakened from their long imprisonment, the Hierarchs fled once freed, and Avalon quickly retreated from the woods. This brought an end to the war and the Hunter was captured and killed for his crimes against Avalon.

Soon after the Queen was restored, peace was made with Avalon. However, it is rumored that there are those from both sides of the war that still harbor ill will to this day.

## The Nymidian War of 1095

In the late spring of 1095PI, the Empire of Nymidia launched a surprise attack on Avalon. The Nymidian forces were led by Lord Valkrist Gloomreaver, the High Commander of the 15<sup>th</sup> Nymidian Infantry. Joining Gloomreaver was Cyrus Leach, the Royal Nymidian Alchemist and a powerful sorcerer. The Nymidian forces descended into Avalon through the pass near Medici and around the mountains into Eastguard. Avalon was taken by surprise, and the heroes were called upon to make strategic strikes against the Nymidian supply lines and supply camps. Though their efforts weakened the invaders position, it failed to have the desired effect. Soon Avalon's forces entered into numerous pitched battles and random skirmishes with the highly skilled Nymidian forces. While the heroes managed to fare well, the regular army did not.

The Imperial High Inquisitor Meikos boldly came into the Avalonian camp to deliver a missive to the Duchess from the Empress Valna I demanding Avalon's surrender. The Midlantian Guard attacked Meikos and captured him. Upon his person was a magical card, and when the Duchess examined it, the voice of Gloomreaver was heard. The Duchess asked, "We have captured Meikos, how do you plan on liberating him?" "Like this!" responded Gloomreaver and with that his hand reached out from the card and drew the surprised Duchess into the card and into his clutches.

Avalon's morale broke at the loss of their beloved Duchess and in the Battle for Medici, the Avalonian Heroes met defeat and were driven back, forcing them to give up Medici. The battle in Eastguard fared worse and by the beginning of the summer, half of Avalon was lost.

Sir Edmund Du'Bois, Count of Aquilar, arrived in Avalon at the beginning of summer with the Duchess on a leash. He demanded the surrender of the heroes and armies of Avalon and announced his plans to marry the Duchess Blaize. It was during the wedding that Avalon was surprised by the return of Zakk Swansong from the grave. His return and impassioned speech roused the Heroes of Avalon and a final battle with the occupying forces erupted. Du'Bois was defeated by the Heroes of Avalon and the Duchess Blaize was freed. At the height of the excitement, Zakk asked for the Lady Blaize's hand in marriage and she happily agreed. After they were married, Zakk declared Avalon a kingdom and thus began the short reign of King Swansong and Queen Blaize DuRhone.

But fate was not yet done with Avalon, and deep in the woods a new evil was awakening. In June of 1095PI, some of the Heroes of Avalon, hearing the call of the Mother, created a place of worship to her, and the Avalonian Druid's Grove was created. This act of faith by a few awoke a terrible creature from a deep slumber; a creature that came to be called the Druid Eater. A long time ago a Forrestal –

a living embodiment of Nature – became corrupted and was sent out to kill the Druids of Avalon. Its task done, it went to sleep for a long time. Now new Druids had come to Avalon and the Druid Eater began its rampage attacking any Druid it could find and killing them. The Heroes rose up to slay the abomination, only to find their greatest strength, their ability to heal, turned against them, for the Druid Eater could cause pain in any that could heal. Though Avalon did battle this beast for many moons, the fight always ended with the monster getting away. The then Baron Derek Ironheart of the Dale took charge of a small group of warriors – the only ones without healing magic of some kind – and surprised the Druid Eater when it thought it had Avalon at a disadvantage. Finally, after many battles and much death, the abomination was put down in spring of 1096PI.

## Passing Beyond

In the beginning of the year 1096PI, after Avalon had celebrated Yuletide, many of the Heroes of Avalon received a letter of invite from the King and Queen for a special celebration at the 5 Lions Inn. When the heroes arrived, they found a mysterious fog had enveloped the inn. Worse, the fog would allow passage to the inn but prevented any from leaving through it again. The King and Queen were not present at the party and the Heroes did encounter many strange occurrences that night. Towards the end of the evening, a portal did open up in the basement of the 5 Lions Inn and several heroes went through to investigate. Those heroes encountered many trials, which eventually lead them to a chamber where sat the King and Queen. Blaize addressed the assembled heroes and told them it was time to bid farewell; they were going to go Beyond and with their passing so too would go the Nine Dragons and Nine Hierarchs and thus usher in the Age of Man. Many revelations were made that night, some of which the heroes never spoke of, but two shocking revelations spread quickly across Avalon. The first was that King Zakkahn Swansong was really Oliver Descante, the first Duke of Avalon sent by the Emperor to quell the Trollish Uprisings. He also revealed that from time to time he would return to Avalon and take his Duchy back, leading and guiding Avalon towards Her destiny. He said that destiny was at hand and that Avalon would soon face her greatest challenge. The second revelation was that their heir would find the royal scepter and whoever found it would be the rightful ruler of Avalon.

Then the King and Queen went through a portal in the basement of the 5 Lions Inn and went beyond. The ground shook and everyone everywhere in the world felt a tremble pass through all things as the Nine were drawn through; the Universe had changed. What else was seen at the portal and what else was revealed at the meeting has never been learned, but some who were there still live in Avalon today.

The dark night was not over. When those heroes who were present returned, they found an old enemy had arrived. Meikos walked out of the fog and mist that had enveloped the 5 Lions Inn and was taken into custody. He told the assembled heroes and nobles of Avalon that the Empress Valna I had begun a great and terrible ritual that would take one year to complete. This ritual if successful would turn Valna into a god and destroy much of the world in the process.

This night also saw the passing of one of Avalon's staunchest defenders, the Lord Sir Lunk of Kilmer, who though taken by the very clutches of Death himself, still lingers about Avalon to this day – or so the stories go.

## Reign of King's Regent Derek Ironheart

For the next several months after the King and Queen went beyond, the nobles of Avalon searched for the royal scepter. Without a clear line of succession and no central noble ruler, Avalon suffered from internal discord. After a few months, the nobles decided to swear fealty to the then Baron of the Dale, Sir Derek Ironheart, to put some order back even without the scepter found.

Valna was indeed getting ready to cast a great ritual and while Avalon squabbled amongst itself, she pillaged her Empire for the resources needed to elevate herself to godhood. Stories trickled out of the Nymidian Empire of great atrocities and strife, as not all of her True Nymidian children agreed with her actions. Of course this strife was born out of fear for their own existence, rather than some altruistic intention.

After Regent Derek took control of Avalon and quelled, if not completely eliminated, the problems of Avalon, attention was turned to the greater threat and plans were made to invade Nymidia.

## Reign of Duke Jerrin Dragonheart

Amidst this time of great chaos and uncertainty came a man calling himself Jerrin who claimed humble lineage. He walked among the people of Avalon and lent aid when needed. Quickly he befriended a number of Avalonian heroes. Then one day, he called to several of his new friends to meet him at Castle DuRhone. The adventurers met and were granted entrance to the strange mystical place. Several hours later, the group emerged with Jerrin leading them, carrying the Royal Scepter in his hands. Upon their return to Avalon, he announced himself as Jerrin Dragonheart, son of Duke Aleric Dragonheart and heir to the Kingdom of Avalon.

Regent Sir Derek heard of this man's claims and strode forth to challenge him. The two men met as the heroes watched on and waited with baited breath to see what would happen. It is said that Sir Derek asked for the scepter and proof of Jerrin's claim. Jerrin responded with a letter written in the Queen's own hand verifying the validity of his claim. A paladin was called forth and no lie was detected in Jerrin's claim.

Finally, after long, tense moments, Sir Derek, Baron of the Dale bent knee to Jerrin Dragonheart, renounced his claim to the throne and did swear fealty to the new ruler of Avalon. The townsmen and heroes present did rejoice and the other nobles of the land bent knee and swore their fealty to the rightful ruler of Avalon.

The first act Jerrin did was to name himself Duke and Avalon a Duchy, saying that there will only ever be one King and Queen of Avalon and no one to come will ever take that title.

Duke Jerrin Dragonheart wasted no time and quickly began marshaling the forces of Avalon to move against the Dark Queen.

## The Prophecy Fulfilled

In the summer of 1097PI, Avalon went to war with Nymidia, but they did not do so without help. All the great powers of the universe came together and bade their followers to stop Valna before she could complete her ritual. Indeed, never before did the High Lord, the Mother and the Dark Lord work towards a common end.

First, Avalon reassembled the Star Golem, a golem made from a strange metal that fell to earth a great long time ago and forged by the master smiths of the Dwarven nation to destroy a threat long ago. Avalon, a decade earlier, assembled the Star Golem to kill a man,

named Karn, who had risen in power and also desired to stand amongst the stars. But the golem was incomplete and could not be animated. The master alchemist Pockets found a way, for during Lord Sir Lunk's funeral, he took the man's heart and using ancient and arcane alchemical secrets, transmuted the heart to gold. It was this heart and the spirit of one of Avalon's greatest warriors that would be used to animate the Star Golem. Indeed successful, the Star Golem arose and stood silent waiting for orders. Pockets was revived from his efforts and ordered his creation to travel north to the Crystal City and slay the Dark Queen. Many who were there that day say the golem was not like other golems, for a glimmer of life sparkled in its eyes as it purposefully strode north to complete its task.

Avalon marched behind the Star Golem, but quickly fell behind as the untiring creature ran far ahead. It was not until the Heroes of Avalon stood at the very gates to Valna's palace that the fate of the Star Golem was known; for the trail of destruction stopped at the body of the most powerful Balrog ever known and was found still lying, festering at the gates of the palace.

Avalon's fight to the Crystal City was short and quick, most of the forces having been killed either by Valna as sacrifices to her ritual, or to the might of the Star Golem. Once the Host of Avalonian Heroes reached the gates of the great city, the devastation and insanity of Valna's desires were made apparent. Those who practiced the mystical arts felt the draw of all magic into the ritual, making it almost impossible to cast magic in the city without great effort. Time was short and Avalon had to act fast.

For two days, the Heroes of Avalon attacked the remaining Nymidian forces. The Avalonian Heroes fought as hard as ever they did and cut through the forces throughout the day, until at last in the dead of night, tired and low on magical power, Avalon faced Count Colin Draegosian, Brigadier General of the Imperial Host, and son of Valna herself. It is said that Draegosian was the greatest warrior that ever lived and he did live up to that reputation. Avalon fought for hours, killing Draegosian's elite forces and eventually facing off against Draegosian himself. All night and into the morning did Avalon battle this man, but slaying him once was not enough, for just when Avalon thought they had him down, he called to his mother with a great cry for help and he was renewed and the battle swiftly turned. Finally, when the Heroes of Avalon were about to collapse from exhaustion, did Count Colin Draegosian, greatest warrior in the world, fall for the last time.

Later that night, a young half elf, known to her friends as Alex, found a single lit candle in the woods. When she grasped the candle her destiny was revealed to her. She was to slay the Dark Queen in her lair.

The next day, after Avalon rested, the ritual chamber where Valna was casting her ritual was stormed. The forces that opposed them were no match for Avalon and the living soldiers quickly fell. Valna, however, was not to be so easily defeated, for locked away for millennia were Carthidian Eternals, part golem, part undead, and almost indestructible, and she sent these against Avalon. After a long fight, the eternals were destroyed and now only the door and a handful of guardsman stood between Avalon and the Dark Queen.

Precious little time remained before Valna completed her ritual; her tactic of slowing down the Avalonian advance to gain time was successful. There was no room for error, no time for second chances. Avalon threw open the doors and began their final assault.

The Dark Queen paused in her casting and saw her doom standing among the Host of Heroes. Enraged and defiant to the end, she pointed her finger at Alex and drew upon all her Imperial might and

with unerring accuracy, hurled dark necromantic energies to obliterate the one destined to defeat her. And obliterate Alex she did. The fighting stopped. Avalon was broken, their only hope defeated before they even started. Valna again called upon her Imperial might and covered the heroes and began to gloat over her victory. She turned to her men and ordered them to sacrifice the heroes to her ritual, thereby completing it and achieving her goal, but before she finished, a portal opened up and Alex stepped through and charged the Dark Queen with her staff. Valna was dumbfounded and stood gaping at the sight. Alex drove her staff through the Dark Queen who then fell into her own ritual and was consumed.

The epic energies from the ritual began to spiral out of control and Avalon had no place to run to. Meikos, seeing his end, invoked his ritual of leaving and attempted to flee. But the wild energies empowered the ritual and the portal stayed open, allowing the Host of Heroes to escape away from danger, completely victorious.

But how did Alex survive you ask? A young Drake by the name of Calibahn was waiting to save Alex, and save her he did.

## The Council of the Damned

That fall and winter, Avalon rested and recovered from its long war and once more had time to look in upon itself and its own domestic issues.

Other forces that were freed before Avalon marched against Nymidia had been quietly gathering power and making plans. That cold winter would not have allowed mortal adversaries to move against Avalon, but this foe was not mortal and in the deep hidden recesses of the forest it planned and waited.

From under Castle Kilmer an ancient Lich, Darkwind and his Court of the Damned had been freed. Among the council members was Lazarus the Shadow Lord, Mia the Mummy Lord, Meldek the Vampire Lord, a Wraith Lord, Wight Lord and a Death Lord.



The Council first came to Avalon one cold and snowy night. Darkwind declared himself ruler of Avalon and named many of his undead minions as rulers of the Avalonian Baronies.

Avalon did battle with these creatures over the next several months and, if not for the infighting amongst themselves, Avalon might have lost the fight. These undead were more powerful than one could imagine and their leader's power rivaled even the Dark Lord of the Undead – Zebulon himself. Avalon seized opportunities presented by their infighting and began killing off the members one by one, Mia was first, betrayed by Lazerous, and the Wight Lord soon followed. The Wraith Lord died at the hands of the Order of Paladins when caught alone and unawares.

Darkwind did not take such bold acts lightly and came himself to Avalon time and again to drive off the heroes who were forced to hide themselves to survive.

Eventually, by the early spring, Avalon learned the source of the lich's power, the wild energies released from Valna's interrupted failed ritual. With the help of the Elven Queen and many difficult and dangerous quests, Avalon denied the lich his power and forced him to retreat and rethink his plans.



## The Ascension Wars

The summer of 1098PI began what has become known as the Ascension Wars. After the Councils went beyond, scholars believed that there was an end to such things in the world, but as Avalon quickly learned, only the beings on those Councils left, the positions themselves still existed, but were just vacant awaiting new powers to step up and assume them. Each position on either Council had a Mantle of Station and an Item of Power that would allow another to assume the role. The summer saw many powerful beings – both on the side of Light and Darkness – seeking the service of their mortal followers to aid them in gaining a seat on their Council. The Drakes known as Calibahn and Mardux ascended to the Council of Dragons and the warlock turned demon, Trom the former Baron of Eastguard, the imp Palimander, the lich Darkwind ascended to the Council of Hierarchs and assumed the names Ophidia, Pid, and Zebulon respectively.

Many quests and great battles took place as both sides not only struggled to gain power for themselves but tried to prevent the other side from winning their prize. Darkwind sought his item out by using Avalonian heroes he had sorcerously enslaved during an earlier battle. His Court of the Damned was ruined, both because of the efforts of the Avalonian Heroes and because he consumed them to help him in his quest to ascend. The Vampire Meldec and the Shadow Lord Lazarus survived the carnage to trouble Avalon again another day.

The end of the fighting came when Palimander brought Hell to Midlantia and merged the two realms. Mardux saw what was coming and lead the heroes to the Lands of the Dead, where they fought a great number of undead. The Heroes of Avalon returned to find their world changed and not for the better.

Then Mardux stood against Palimander and ordered him to turn things right again; the imp agreed for the price of his Item of Power, which was held by Mardux. After setting things right, he was given what he wanted and ascended to the seat of Pid, assuming his name as well. The Ascension Wars had ended, but there would be other battles as the fight between the Light and Darkness continued.



### Tarsus and the Breaking of the Seals

After the Ascension Wars, Duke Jerrin mysteriously disappeared and eventually was presumed dead by most. Count Kyle DuRhone, a distant relative to Blaize DuRhone came to Avalon soon after and

claimed the title of Duke. His reign had barely begun when a new threat arose in Avalon.

Tarsus was one of the few True Nymidians to escape both Valna and Avalon. Where he fled to is unknown, but return he did as the cold of winter began settling on Avalon. One dark night he came back with new knowledge and a new purpose – revenge. Tarsus learned that long ago five great seals were created to bar entrance to this world of some great unnamed evil. These five seals were placed in different areas of this part of Midlantia and each was guarded by a Lion, no ordinary lion but a powerful, magical creature whose purpose was to guard one of the seals. One of these seals was under the 5 Lions Inn. Tarsus knew he could never defeat both Avalon and the Five Lions, so he sought out the Midlantian Guard Banner, for legend said that should the banner ever fall in battle, all Midlantian Guardsman who have passed would return from the dead and punish those who let the banner fall. Tarsus seized control of the Risen Guard and drove them into the heart of Avalon, into the 5 Lions Inn, where the Lions fought an epic battle. The Host of Avalonian Heroes were not in the city when the attack came and upon their return, they found the citizenry driven away and a layer of dust several inches thick upon the ground. A few of the Risen Guard remained and the Heroes made quick work of them. Inside the 5 Lions Inn was the last Lion, Azygoüz, named after the mighty mountain in the Plains of Gehenna.

On the edge of death, and barely able to be healed, Azygoüz greeted the Heroes with a cold welcome. He told them that his brothers and sisters were nearly destroyed and had turned themselves into statues to survive. These statues had been taken and must be reclaimed. The Heroes of Avalon took up the challenge and set out to find the lost statues, eventually reclaiming them and returning them to Azygoüz the Lion.

For many long months Avalon and Tarsus did fight. Tarsus always escaping and not always the loser, until one night in the ruins of Altic, Avalon faced off against the madman who sought to destroy the world and, after destroying his phylactery, finally defeated Tarsus and brought an end to the conflict with him.

## The Reclaiming of the Highlands

Refugees from the Highlands came to Avalon, sometimes in small numbers, sometimes in larger, but come they did and settled in an area the Earl of Medici had set aside for them. These people, strangers in a strange land, fought for many years alongside the Heroes of Avalon and defended the nation that gave them shelter from their war ravaged homelands. Many made friends and, though they never called Avalon home, they did protect it as fiercely as if it was.

Then the time came, those Highlanders who survived the hard journey to Avalon and trained and learned all they could, felt ready to take back their homeland from the Bainites and Ogres who drove them out. They turned to their Avalonian friends and allies and asked for help in taking back their homeland. Avalon and most of her Heroes agreed and together went and did battle with the minions of the Nine once more.

Long and perilous were the battles to reclaim the Raven Banner and the Sword of Cullen, the two items that Highlander Lore said was needed to reclaim their home. Finally, the Highlanders and their Avalonian allies entered the field of battle outside the Bainites' main stronghold, a castle that once held the King of the Highlands. Then from the gray mists that surrounded the battlefield came the Bainite army, lead by the Hierarch Baine himself. No one knows how Baine



managed to remain here when all others were drawn away, but remain he did and was here to defend his conquered territory.

The Highlanders and Heroes of Avalon fought long and hard and finally in the end, Baine was driven off and the Bainites either killed or sent running away. The battle won, the Highlands were once more in the hands of Highlanders, but the war was far from over and still Bainites tried to conquer the Highlands once more.

## Reign of Duke Sir Molin Hearst

During the war, much to Avalon's surprise, Jerrin Dragonheart returned to Avalon, meeting his people in the Highlands. After the war was over, and as Avalon returned home, he declared himself Prince and appointed Duke Kyle to rule in his stead. Soon after, however, Duke Kyle disappeared and it was widely accepted that his research into strange sorceries was responsible.

Many moons earlier, Sir Molin Hearst, then Count of Islewatch, led a stalwart band of heroes to a secluded part of Midlantia where sat an ancient temple. This temple, the band would learn, was the home of a guardian that protected the prison of an ancient Dragon who had betrayed the High Lord and entered into the Dark Lord's service. This abomination was of ancient and terrible power and even the Dragons of his time could not destroy him only contain him in a prison. To ensure his eternal imprisonment, a temple was built over the doorway and a guardian Solar was set to ensure it never escaped. This Dragon's name is not known, but all called him only Blasphemy.

During the time of the war with Valna, a group of Dark Paladins were directed to assault the temple and claim the Solar's heart for their dark ceremonies. Evil won that day; the Solar was killed and the gateway to Blasphemy's prison stood unguarded for the first time in eons. The abomination's power grew and it clawed at the gates, attempting to free itself before things could be set right.

Count Molin learned only that a temple to the High Lord had been desecrated and he and his friends set out to cleanse the temple and restore things. When they arrived, the temple was guarded by a powerful ethereal force of evil and hordes of undead drawn there by the call of Blasphemy. The battle did not go well and twice the band was driven back. All but defeated, Sir Molin knew he needed to win this fight and told his friends they should leave, not wanting to imperil their lives further. None left, and a third time the band assaulted the temple. This time Sir Molin drew on the power of the White Fire sword crafted by Countess Blaize and Molin's wife to sanctify the building. The prayers and sacrifice of the band was heard and the sword erupted, killing Sir Molin, and removing the taint of evil from the building. But that was not the end of the Paladin, for the High Lord saw fit to ascend Molin, raise him into a Solar, and set him to the task of guarding the gate to Blasphemy's prison.

Many years later, at the end of the war to reclaim the Highlands, another was chosen to guard the prison and Molin's duty was at an end. He returned to Avalon and soon after, when no sign of Duke DuRhone was seen, he claimed the Ducal seat and became the next Duke of Avalon in the year 1099PI.

## Blasphemy Freed

For several years, only minor problems bothered Avalon and the land once more prospered. But evil never sleeps, and, while away on a mission, the Heroes of Avalon returned home in time to see a powerful undead lich finish casting a great ritual to rise up an undead

Dragon, not just any Dragon, but Blasphemy itself! The pile of bones animated and unlife filled the dreaded creature whose first act was to consume and destroy the lich and his servants. The Heroes of Avalon stepped through a magic portal that they used to take them home and came faced to face with the awesomely terrible visage of a Dracolich. The battle was swift, and in moments with a beat of its wings and a touch of its terrible black ethereal flames, half of Avalon was cut low. The Host of Heroes, already weak and tired from its battles that night, fled the field, taking as many of the wounded as possible.

The Dracolich Blasphemy terrorized the lands for months as the heroes and nobility sought a way to defeat this creature. Finally, Count DuRhone, who returned to Avalon a few moons earlier, revealed a plan he had. He would cast a ritual to trap the undead abomination in time, forever imprisoning it away from doing harm.



The components collected, the ritual site set and the trap baited, Avalon braced itself to do battle against the Dracolich. Blasphemy arrived on the field of battle and called out to his undead minions who swarmed from the woods to do battle with Avalon. The Dracolich laughed at Avalon's attempts at subterfuge and revealed his knowledge of the trap. It was too late to turn back now, this was to be the final battle; either Avalon would be victorious or all would perish. The ritual began and the giant bone Dragon moved in for the kill with his minions attacking from all sides. It was all the heroes could do to keep Count DuRhone safe while he cast the ritual, but hope was quickly fading and all seemed lost.

Then, the Dragon Laylon strode onto the field of battle in his full draconic form and called out to Blasphemy and gave him challenge. The two mighty creatures fought tooth and claw, striking such mighty blows against each other that no mere mortal could have survived any of them. Avalon, with renewed hope, drove back the undead and without their master leading them or calling to them, their numbers dwindled and the heroes were able to join the battle and aid Laylon. For hours the fight ensued; the might of the abomination barely being checked by Laylon and the Host of Heroes.

The Dracolich began to tire, its wings had been torn off in the fight and one of its legs was severed. It became obvious Avalon could win this fight, but just then, Count DuRhone finished his ritual and cast the horrid Dracolich into the shapeless, timeless void he had prepared

for him, inadvertently sparing the monster from his inevitable destruction. Blasphemy, with his last act of spite and hate lashed out and drew Count DuRhone with him. Blasphemy's final cry of "I SHALL RETURN!" silenced the battlefield; the battle was over. Avalon had won, but had She?

## First Contacts

Peace once more settled on Avalon, and the heroes went back to doing what heroes do, adventure. A little remarked event took place late that winter, two men, claiming to be from a land far to the west, arrived over the seemingly endless plains and prairies. They told of a vast empire many, many times the size of even the great Nymidian Empire. The land was called Telvenden and soon this new land would shape Avalon in ways no one was prepared for.

Emissaries and Ambassadors from various duchies within Telvenden began arriving in the City of Avalon to establish trade relations and visit this new land. The people that came represented the Western Empire – as Avalonians came to call it – and it would seem Avalon had found a new ally, but along with the new, bright faces came some troubling stories; stories about the extermination of the Elves of that land that were supposedly evil and their allies, the Druids, who once long ago dwelt in the forests of the Western Empire and cause of a great Cataclysm. The Elves and Druids of Avalon received much contempt and suspicion from these new visitors. There were other, perhaps more troubling rumors that came from the west; rumors of a Vampire Emperor and a forest as dark and many times more vast than the Darkwood Forest was filled with undead. These rumors would soon show themselves to be more fact than fiction.

Avalon had other visitors to its shores. A race of gold skinned people calling themselves Carthidians appeared, seemingly out of nowhere, and came to Avalon claiming the land as theirs. They did not come alone, they brought slaves and magical gem constructs to serve as their soldiers. Avalon would soon learn that the Carthidians did come out of nowhere, for long, long ago they cast a great ritual to send themselves forward in time to escape the fall of their empire; an empire that spanned from the frozen north to the very southern tip of Gehenna.

The first battles did not go well for Avalon against the Carthidians and each one saw new challenges. Eventually, the Carthidians were driven back, more from a lack of supplies than the might of Avalon.

Later, that spring, almost a year after it was banished and true to its word, Blasphemy returned, this time a little wiser and more hesitant to engage Avalon directly. The abomination sought more minions to do its bidding and found them in the wastelands of what was once the proud and powerful Nymidian Empire. It called the undead to it and formed armies with which to assault Avalon. Reports came in that large armies of undead had moved to the border of Avalon, one in the North, by the Mistwood and one to the east, near Coventry. For months these armies just sat there waiting, a constant looming threat that did much to darken the hearts of all Avalonians.

The summer saw increasing activity from the Carthidians who began erecting large obelisks that drained magic and funneled it to the south, to the Carthidians' risen city. Time was growing short, whatever dire plan the Carthidians were hatching, Avalon had to act. Still on her borders, the great undead armies stood, shrouded in darkness and eternal overcast. Avalon was pressed from two sides by two overwhelming forces, both threatening to crush the Duchy.

Then the Carthidians attacked in force, driving the heroes and the armies from the City of Avalon. During that desperate battle the Warlord, Baron Sir Drae, was captured on the field of battle and

Duke Molin turned to a newly knighted Sir Kendrick, once squire to the captured warlord and made him the new Warlord. Sir Kendrick called a retreat and brought back the heroes to Nish, where a few months earlier in an attempt to destroy one of the Carthidian's obelisks, a flawed ritual had created a magical dead zone. The Carthidians and their constructs could not enter the town and any who did were destroyed.

Expecting an attack at any time, Avalon dug in and waited, and waited, and waited for an attack that never came. Scouts were sent out and, other than a few guards, they found nothing until they reached the City of Avalon where the Carthidian forces were moving in and spending time renovating the city. The Ducal Castle was still in Avalonian hands. More forces moved in by the day and the Carthidian plan remained a mystery.

The new Warlord wasted no time and devised a plan of attack. The forces of Avalon would attack the City of Avalon at midnight in three days time. The Heroes of Avalon would move out and attack the Carthidian city and destroy their tower in desperate hope that something would go in their favor. They had to reach their objective just before the regular Avalonian armies attacked. The stage was set, the forces marshaled, and the new Warlord led the heroes out of Nish in a desperate fight against the Carthidians guarding the town. After a long battle, and with Avalonian help arriving from those heroes not present during the retreat, Avalon won its first major victory in this conflict.

A hard forced march was undertaken down to the lands south of Ultor, through the Great White Swamp and dangerously close to the Darkwood. On through most of the night they pressed, facing opposition at every turn, until finally they arrived at the great monolithic obelisk.

After a brief rest, the heroes charged the obelisk and found numerous elite forces inside, along with a sorcerer attempting to cast a ritual to raise the Carthidian capital city and awaken more of their servants and constructs. The magical power that was being collected over the months crackled in the air above the heroes as they fought.

Then, if things could not get worse, the abomination Blasphemy tore a hole and entered the obelisk. He tore apart the sorcerer and attempted to step into the ritual circle and consume the power for himself, the real reason his forces had not attacked revealed. Blasphemy was weakened from his long imprisonment and in order to be healed, he needed the power collected by the obelisks. Blasphemy was not the only visitor that night. Laylon once more showed up to fight his hated enemy. The two stepped into the circle and fought each other and for control of the power, but Laylon was immune to magic and before long there was a terrible explosion. All went dark and after many pensive minutes the heroes awoke to find all the Carthidians and their constructs destroyed and the human slaves that remained surrendered or were put down. The obelisk was destroyed along with all the lesser ones, the heroes would soon find out. The Dragon Laylon along with the abomination Blasphemy perished in the explosion. Both only live on in memory.

The Host of Heroes returned home to find all but a few of the Carthidian forces had been defeated; those that lived were driven off after a short but decisive battle. With the power of the Dracolich gone, the magical gloom that protected the undead also vanished and the vast legions of undead were destroyed by the light of the rising sun.



## Reign of Duke Kendrick Monaghan

At the end of the year Yule Tide celebration in 1103PI, and during the yearly Noble Reaffirmation ceremony, Sir Molin Hearst passed his Ducal title on to another, stepping down after over five years of rule, the longest in recent history, to none other but the new Warlord of Avalon, Sir Kendrick Monaghan. Many were surprised by this move, but the title had been passed and the nobles swore their oaths of fealty to their new liege lord.

The first act of the new Duke, after receiving his oaths of fealty from his nobles, was to order the execution of Lord Sir Johann of Lockhart for breaking the laws against necromancy, sedition against

the rightful rulers of Avalon, and conspiring with the enemies of Avalon. Duke Kendrick called Lord Johann forward in front of the assembled nobleman and commoners. There he confronted Johann and ordered his death. Quickly, the assembled nobles struck and tried to strike him down, but Johann was a powerful Warlock and he protected himself within a Magic Sanctuary spell. He began to profess his innocence and convince Duke Kendrick this was all a mistake. The Duke ordered Count Kyle DuRhone to remove Johann from his sanctuary. The count obeyed and Johann was quickly dispatched.

The new Duke took some time to inspect his lands and take advantage of the time he had to tie up loose ends and bring some stability to the duchy after the war. The Carthidians had been trying to bring the war they started, and ultimately lost badly, to an end with peace offers and gifts to Avalon. Almost six months after the war's end, Duke Kendrick signed a peace treaty accepting the Carthidians complete and total surrender. Besides the gifts already given, the young statesman only exacted minor war reparations for the damages done to Avalon during the war. In addition, he allowed for free trade between Avalon and Carthidia.

## The War with Graythrone and the Death of a Queen

In the spring of 1104PI, the plans laid by agents of the Duchy of Graythrone came to a head. Over the past several seasons a group calling itself C.R.A.P. (Citizens Rebelling Against Parasites) had preached the imagined ill deeds of the Elves from Mistwood. Their propaganda campaign turned many normally sane citizens of Avalon into a mob of discontents. The best efforts of the nobles of Avalon could not root out their enigmatic leaders who always seemed to sneak off and hide under some rock and be one step ahead of the law.

Then one day in the late spring, while returning to the Mistwood from an extended visit at DuRhone Castle, the Lady Yanna Nefay and her party were attacked by members of CRAP. Her party was overrun by the sheer number of people and the Lady was forced to open a portal and flee to the Court in Mistwood. This was the opportunity the undead leaders of CRAP were waiting for, and they charged through the portal. Many stories have come out of the ensuing battle in the High Court of the Elves, but they all end the same, with the death of the Elven Queen who had ruled for so many countless years.

The young Yanna Nefay, the old Queen's niece, was quickly crowned the new Queen of the Elven people and she turned to her Avalonian allies for help in reclaiming the former queen's body and exacting vengeance upon the perpetrators of this atrocity. Duke Sir Kendrick granted the Queen's request and together they made plans for war. The Avalonian Heroes went forth and gathered the components needed by Count Kyle DuRhone to cast a ritual that would open a portal to the Western Empire into the Duchy of Borian. At the last minute, the Count vanished and the being known as The Golden Jackal, Opener of Ways, appeared to aid Avalon in her plans to invade the Western Empire and the Duchy of Graythrone. The portal open, the Heroes and best and strongest troops from all the baronies marched through into a strange land, along with the entire Elven Army lead by the new Queen.

No sooner had Avalon arrived in Borian, one of the lands of the Western Empire, then reports of civil war and political turmoil reached them. The half-vampire Emperor Mal Koten had turned upon his court and slew hundreds of his nobles before he was brought down. The Imperial Guard turned on the assembled nobles and calling upon the Dark Lord slew many of them. Finally, the Dwarven Emperor Denthar Alten and his allies brought down Mal Koten and fled the capital.

Graythrone had made its move against the Empire and undead legions poured out from the Heart of Darkness and the armies of Graythrone and their allied Duchies went on the march.

It was soon learned that the Kormin Dukes, long thought dead but living in undeath, were behind all of this. As Avalon and the Elven people marched closer and closer to their goal more and more of the lies and deceptions that had been spread for many, many generations were being exposed. Contact was made with Emperor Denthar Alten and a coordinated attack against the heart of Graythrone was made. The battle with the Kormin Dukes and their forces was long and hard and Avalon and her allies battled through the night and early morning hours to finally gained access to the castle where the Kormins fled to. The Elven Queen's body was recovered and Avalon pressed on into the castle chasing down their enemies; but the Kormins had one more surprise for Avalon, a portal to the Heart of Darkness stood open, waiting to spirit away the Kormins.

## The Kalix Invasion

During the war with Graythrone, the nobles and heroes of Avalon, learned of four great Obelisks of Darkness that protected Castle Graythrone. In an effort to counter the power of these towers, the Duke ordered the heroes to collect the components necessary to cast five Towers of Light; four towers to counter Graythrone's towers and another to turn the tide in their favor. When the heroes entered the field before Graythrone, they invoked the embedded rituals. Things did not go as planned, however. While the Obelisks of Darkness were neutralized, the tremendous concentration of magical energies in the area tore the fabric of reality and opened a rift in the heavens. After a few days, all of the towers cracked and crumbled. The damage, however, was done.

Over the next several months, strange creatures began to appear in Avalon. Early in the year 1105PI, reports and rumors started to reach the City of Avalon of a creature that was, while still living, a creature of necromancy. These creatures called themselves the Kalix and brought with them a new plague from their destroyed, undead homeworld through the rift.

The heroes discovered that the Kalix where hatched from eggs which grew on great undead trees called Blight Trees. These breeding trees



of the Kalix were planted upon nodes of magic which fed and empowered the trees. Eventually, the node was corrupted and destroyed. The Druids implored the duchy to help them stop the newest undead threat to the Mother. They did not need to plead long or hard for the threat to Avalon was clear. Over the summer of 1105PI, many of these Blight Trees were rooted out and destroyed, but a great amount of damage was already done to the land. Scars of dead earth were all that remained where these trees grew. The Druids called upon the Mother to bring life back to the land once the Necromancy was removed. They could not, however, heal the nodes of magic that were destroyed by the trees.

## Nehru and Kaleb Dhur

During that same summer, a new demon was encountered calling himself Nehru. He began to cause the duchy trouble as his followers worked to bring their master, Kaleb Dhur, back to power. Nehru was not alone in his efforts. Kaleb Dhur's high priest, the Dark Cleric and sorcerer Valen Shae, also worked to free his master and bring him to prominence.

The demon Kaleb Dhur was a powerful, ancient demon that had the power to drain the soul, and with it their knowledge and power, of anyone he killed. In this way, eons ago, he rose to great power in Hell. Eventually he challenged the Nine and waged a war against them. Bazmodeous lead the Nine to defeat him, but they could not kill him. So, instead, they imprisoned him in some hole in Hell leaving him there to be tormented for eternity. As is the way of such things, he was forgotten. Then Nehru found him, bargained for powers and favors, and freed him. But the world had changed since Kaleb Dhur's imprisonment and he could no longer walk Midlantia feasting on souls to regain his power with ease. Nehru knew of a way to enter the mortal world and used this to force Kaleb Dhur to keep his word.

Nehru began raising a cult to serve Kaleb Dhur and offered sacrifices of souls to feed his master's hunger. Quickly, Kaleb Dhur regained much of his former power. The demon began to feast on other denizens of Hell and eventually grew powerful enough to challenge the Nine. This time, however, there was no Bazmodeous to force the other Hierarchs in line. Kaleb Dhur made a move to gain the Mantle and Item of Power for the seat of Bazmodeous; his great nemesis. This raised a mountain containing an ancient portal to Hell.

Avalon came in nearly constant conflict with the ever growing forces of Kaleb Dhur. His minions found ways to summon him to Midlantia where he wreaked havoc and destruction. Three times the Host of Heroes engaged in direct conflict with Kaleb Dhur and each time they lost and were forced to retreat.

Then the sorcerers of Avalon came together and created a ritual they hoped would tear the stolen powers away from Kaleb Dhur and thereby give the heroes a chance to destroy him. A powerful white ritual was created and cast, but it was too powerful for the sorcerers to control. The ritual was not a complete failure, it did tear much of Kaleb Dhur's power. What it failed to do was bring the power to the ritual and instead scattered it across the land.

The following month, the heroes set out to find crystals containing Kaleb Dhur's power. They were not the only ones seeking them, mortal agents of Kaleb Dhur also sought the green shards to return them to their master.

In the end, Avalon was victorious. Nehru was killed, Valen Shae chased into hiding, and Kaleb Dhur defeated. At the final battle, with Kaleb Dhur's body lying broken on the battlefield, the heroes could not find a way to deliver the final blow. They had reached the same

impasse the Nine did eons ago. But one of his former followers, a Gray Elf named Herrin, knew the demon's weakness, self sacrifice. With his soul still bound to Kaleb Dhur, Herrin killed himself so the demon would be destroyed. His sacrifice worked, and, at the end of the summer of 1106PI, the demon Kaleb Dhur was killed. The mountain sunk once more into the ground and left behind what has come to be called the Desolate Crater.

## The Barconian Civil War

For many years, Barconia was torn apart by strife and civil war. One man, Lord Terrin, tried to bring together the warring factions of his homeland. His opposition was the Merchant League of New Psynia – a group of powerful and rich merchants that sought to create a rival to Coventry.

In the beginning of 1107PI, the true power behind the Merchant League was revealed. True Nymidians, offspring of Valna and Bazmodeous, had fled Nymidia after the fall of Valna and taken root in New Psynia. They manipulated the local politics to seize control of New Psynia and several other lands of Barconia. When they tried to seize control of northern Barconia from Lord Terrin, civil war broke out. The first battle of the war, the Battle of the Empty Vale, went to the New Psynians. Two of Lord Terrin's supporters turned on Lord Terrin after their families were kidnapped and threatened with death.

Lord Terrin could not ask for Avalonian intervention directly, but instead turned to the heroes of Avalon for help. Several clandestine operations took place which freed the captive families and struck at the New Psynian supply wagons. This quickly turned the tide of battle in favor of Lord Terrin and his allies. The New Psynians fortified themselves in their strongholds and a long siege was engaged.

Strong spring storms ground the war to a halt. When the weather cleared, Lord Terrin's forces made a decisive strike against the New Psynians and took their major strongholds. When the stronghold where the True Nymidians were held up was searched, an escape tunnel was found. The chase lead south to Avalon where the Host of Heroes waited for the True Nymidians to cross into Avalon and the trap they laid for them. All five of the True Nymidians were caught and killed during the ensuing battle.

Lord Terrin was pronounced Baron of Barconia and then a year later, Count of Barconia. Peace had finally come to Barconia after generations of warfare and strife.

## The Death of a King

The early summer of 1107PI held great joy and sadness. King Olen Whitestone, King of the Dwarves who had lived an exceptionally long time and was a great friend of Avalon, died. His grandson, Kelgar Whitestone, who had come to the Yule party of the prior year in his grandfather's stead, was named as the new King of the Dwarven people.





## The Unification of Nymidia and the Rise of Emperor William Thallman

---

For ten years Nymidia was struck by numerous calamities. Then William Thallman rose from obscurity and appeared in Nymidia around 1105PI when he declared himself as Emperor of Nymidia after killing the risen Richard Llewellyn – the same Llewellyn that slew the old Emperor of Nymidia and brought about the Catastrophe. No one is certain where this enigmatic figure came from. It is known that he calls himself The Necromancer, a self imposed title apparently meant to carry some respect. He is also the Demon Knight of Zebulon and, while living, is immortal. This makes it very difficult to determine his exact age. It is also known that he has the power to control undead anywhere in his demesne much as a Greater Lich would do.

His conquest of Nymidia started with claiming the Duchy of Psynia and half of the Duchy of Aquilar. Both of which were easy conquests with neither being ruled by anyone of any power. The lands he seized were filled with wandering undead which terrorized the citizenry that managed to survive. This victory also gave him a vast army of undead; his next victory was winning the loyalty of the commoners who saw him as their savior.

In the cold of winter, Thallman came to Avalon to seek a non-aggression pact with Avalon, the Mystwood, the Dwarves and Tenthetra. After much deliberation, Avalon and her allies signed the treaty.

Next he turned his attention and new army to Tiriane. He delivered an ultimatum to the various barons, declare fealty or be conquered. At first no one took him seriously and preparations for war were made. Then Thallman's armies moved quickly and orderly through Tiriane, conquering barony after barony. With each victory his army swelled with new undead troops. Before long, the remaining baronies bent knee to their new sovereign.

He then turned his attention to southern Aquilar. The same ultimatum was delivered, swear fealty or be conquered. Devaria – a land carved out by Devin Devarious from the old Aquilar – quickly fell to the might of the new Nymidian Empire despite the fact that Devarious and many of his knights were Dark Paladins.

Now Thallman controlled all of the old Nymidian Empire except Briton. He spent the rest of the year consolidating his power and rebuilding much of the devastated lands of Valna's Nymidia. He began amassing his forces on the border of Briton; his intentions obvious.

An emissary from Briton was sent to Avalon to seek aid in gathering components and materials needed for the upcoming war with Nymidia. Not only did the heroes respond with assistance, but some even went there to help.

During the fall, there were many skirmishes and a few battles between Nymidia and Briton. Nymidia never committed its full force against Briton during these skirmishes and Briton's forces barely held the line. The situation seemed desperate.

At the Yuletide celebrations at the end of 1107PI, the Duchess Marriana Freeborn made an impassioned plea to Avalon for help to save her people from Nymidia.

### The Kurig Invasion

---

The Kurig, dark skinned Dwarves from deep, deep underground began attacking Avalonian caravans stealing their supplies. At first

this was a mere nuisance, but it quickly became a more substantial problem as the Kurig grew emboldened and started attacking several villages.

During the Yuletide feast, King Kelgar Whitestone warned Avalon of this ancient threat from the very pages of their legends. He presented the head of a Kurig and told Avalon that his lands were being invaded by these ancient enemies. He told them that they served Pid as strongly as the Dark Elves served Arachnia. Finally, he warned that the Kurig were making their way to the surface and Avalon should be wary.

Indeed his dire prediction was proven correct. At the end of winter in the year 1108PI, the Kurig attacked Avalon in full force. The duke sent the Ducal Guard with orders to the Baron of Medici to attack the stronghold the Kurig were building in the Black Hills.

The army arrived at the gates to the stronghold and started making quick work of the Kurig and Dark Orcs present. Then the gates were breached and the army started to move into the stronghold, but this was a trap. Before the Avalonian army stood two enormous stone doors which opened to reveal a yawning cavern deep into the darkness of the mountain. Then heavy infantry supported by mages and Dark Clerics charged forth. They hurled poison gasses at the back ranks of the army and were themselves under the affects of many alchemical potions.

The Avalonian army, out matched and out numbered, fled and were chased back to Gronswal which was quickly abandoned and finally back to Wainscoting. The Kurig began to fortify Gronswal after taking it and secured their advance.

Over the next several days the army marshaled and set out to take back their lands and destroy the stronghold. The heroes were called upon to attack various strategic points along the army's path to maintain their strategic approach. The heroes succeeded in their overall objectives, overcoming initial setbacks.

The army engaged the main force of the Kurig outside the stronghold while the heroes attacked the command group within. As the heroes entered the stronghold, they witnessed Valnor the Champion of Pid himself, challenge the King of the Kurig and the High Priest declare Valnor the new king. The old king fled into the Underdark barely escaping with his life. Valnor having no time to pursue him, turned and ordered the Kurig to kill the heroes and a bloody battle ensued.

The battle lasted hours and in the end both forces were near defeat, but the Kurig had the apparent upper hand. Then Baron Sir Dragosian stepped forward and challenged Valnor to single combat to determine the outcome of the battle. Valnor accepted and the two entered honor combat. The fighting was fierce and in the end the Baron defeated Valnor. The Kurig charged forward to claim the body of their fallen king and retreated into the Underdark from whence they came. The day was Avalon's.

### The Conflict Over Briton

---

In the early months of summer in the year 1108PI, Nymidia made its move to attack Briton. In a twist of fate, the Duke of Avalon, many of the nobles, and several heroes also set sail to offer the Duchess of Briton the protection of Avalon. No sooner had the Duke and his party landed in Briton, did the forces of Nymidia attack.

For months prior, the Emperor of Nymidia had sent his ethereal undead into Briton to harass the countryside, and, as a result the people fled to the cities to find security. The overpopulation caused by the refugees brought famine and disease to further break the spirits of Britonians. The forces on the border would harass the defenders

and periodically make preparations for battle. The hopes and stamina of the Britonians were all but spent before the attack.

Once the army of Nymidia invaded, there was little to stand in their way. The army fell into full retreat back to capitol. Briton was on the verge of falling to the Emperor, but his plans were about to be thwarted.

The Duke met with Duchess Marianna and offered her the protection of Avalon in exchange for her oath of fealty. The duchess had little choice and bent knee to the Duke swearing an oath of fealty. Now that Briton was part of Avalon, the non-aggression pact protected them from the empire, if Thallman's word was to be trusted and the treaty maintained.

The Duke, nobles, heroes and new Baroness Marrianna set out to meet the Emperor. The Duke told the Emperor of the oath and how Briton was now part of Avalon. The Emperor flew into a rage. He through insults and challenges to their honor. In the end he stopped his army's advance and declared the lands he had already conquered part of Nymidian soil and East and West Briton were formed.

## The Orcish Invasion of Mistwood

When the heroes returned to Avalon, they learned that the Mistwood was attacked by a horde of Orcs lead by Lucian, the son of Balphagor. These Orcs attacked from surprise and used some strange substance to salt the earth and prevent the wood from growing back. Though the Orcs took massive casualties, the Elves were not ready for such a large attack and they were initially pushed back. After a short time, the Elves counter attacked and drove the Orcs from the wood, but not before large numbers of trees where carted off.

A month later, 20,000 Orcs invaded the Mistwood. The vast majority of these Orcs came from Jemp in the Western Empire who were driven from their home. Wagons full of the Mistwood Bain were carted into the Mistwood and dumped on the ground polluting the conquered territories. Trolls carried in mobile walls made from the felled trees a moon earlier and were used as defense from Elven arrows and to build a mobile fortress. Massive numbers of Orcs were slain as the Elves unleashed ancient magics, but it was not enough. The Queen of the Elves called to her allies for help and then fell ill.

Avalon and Barconia responded. The Barconian army moved north through the mountains to harry the Orc's supply lines and east around the Mistwood joining with Avalonian forces. Avalon sent its main force straight through the Mistwood to meet the Orcs head on. The heroes joined the fighting as well, attacking strategic points.



The fighting was fierce and untold numbers of Orcs perished, but more took their place. Word reached the Host of Heroes in Haralian, a town where they set up their camp, that a main Orcish rush was pressing down on them. The army was sent to meet the press while the heroes moved off to attack a flanking arm of the army. The battle took place around an ancient Elven burial site.

Fighting was fierce in the dark of the wood and heroes soon learned that Lucian was present leading his Orcs. But Lucian was human, not the Orc or Half-Orc they expected. The Orcs were driven back after hours of fighting.

The war did not end there. The next morning another push on the Avalonian position was made by the Orcs and the heroes formed up to defend themselves. This group of Orcs were not the well trained and organized lot they were used to fighting, but a rabble. Then an Elven runner came and reported that the burial site was once more under attack. A group of heroes was dispatched to deal with the problem. They were ill prepared to face Lucian and his elite guard and were quickly cut down or forced to retreat. Some lived to witness his desecration of the shrine and grave. They saw him take from the tomb a magic sword of ancient power. As Lucian fled with his prize, Balphagor's voice was heard declaring him to be his Demon Knight and gifted him with his blessing.

After that encounter, Lucian and his trained Orcs fled leaving the Jemp Orcs leaderless, unorganized and to die. The combined might of the Mistwood, Avalonian, and Barconian armies had already set the Orcs to route, but with their leader gone, the route turned into a massacre.

A vast swath of destruction was left behind and thousands of unburied dead. Over the summer, these dead would pose their own problem for the Mistwood.

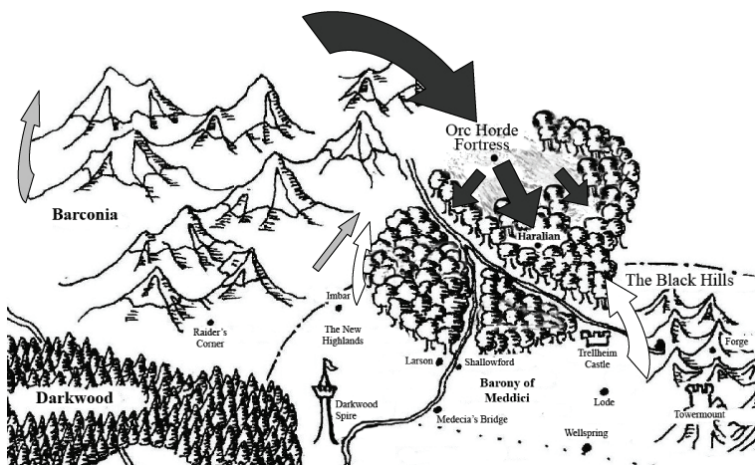

## The Ascension Wars Begin Again

Temples to the High Lord, Groves of the Mother and even unholy places dedicated to the Dark Lord were being attacked by groups of Dark Elves and their Beholder allies. It was learned earlier in the year that the Dark Elves were using an ancient device called the Arcane Enigma Box, which had the power to absorb any form of energy – mystical or divine – and release it later in any form the wielder wished.

After the war in the Mistwood, the Dark Elves grew more bold or desperate. They destroyed the Grove near the city of Avalon and many more dangerous places. The nobles of Avalon could not figure out where they would strike next or to what end these attacks led.

At the end of summer, they would learn the answer. The Queen of the Dark Elves had acquired the Mantle and Power Item of Arachnia and planned on ascending to that seat. She was only a mere mortal and lacked the power to make that transition, so she needed the energy the Dark Elves had collected in the Arcane Enigma Box to give her the power she needed to complete her ascension.

One dark night, the Host of Heroes received word that a large number of Dark Elves were moving near by. The heroes set out to stop them, but they did not anticipate encountering the Queen herself. Her loyal minions bought her time to use the things she had collected and ascended to the seat of Arachnia before their eyes. Empowered and enraged, the Hierarch vented her fury upon the Avalonians present.

Arachnia was not the only being to ascend that night. For many moons prior, a traveling scholar and sorcerer had visited the heroes at the monthly gatherings and become friends with many of them. It turned out he was more than he seemed, for Evander the Scholar was really a powerful Drake. He too was on that field of battle and when the Queen ascended, so he too took up a seat on the Council of Nine.

Upon that field of battle, two titanic cosmic forces did battle. Arachnia calling upon the powers of Hell to bend the universe to her will. Evander called upon the powers of the universe to undo the death she was causing. Great rends in the earth appeared as their wills and power were pitted against each other. The very earth cried out in anguish as their fight destroyed it. But the Mother would not stand for this transgression long. A Forestal arrived and ordered Arachnia to depart, to leave this world and abide by the ancient pact.

She refused and the Forestal moved against her. His massive strength and power wounding her grievously. Arachnia tried to bend the universe to her will and destroy the Forestal, but she could not touch him with her power. Evander, after healing the Avalonian heroes, joined the Forestal and together drove Arachnia from Midlantia.

The battlefield grew quiet after the last of the Dark Elves were slain. The Avalonians looked upon the devastation that was wrought and were stunned to silence. Eventually, Evander and the Forestal parted ways peacefully.

The heroes needed to find a way to heal the land. They turned to the old stories where, over a decade ago, Avalon used the Horn of the First Unicorn to heal the land after another great war left Avalon in ruins. They set out on a great quest into Castle DuRhone where the Horn was kept.

After the completion of their quest, they used the Horn to heal the Dale lands. They then brought the Horn to the Mistwood to heal those lands as well. They fought a great number of undead in the wood but not nearly as many as they had expected, for many were drawn into Nymidia. In the end, the Mistwood was healed and the Horn's power was expended. The Horn of the First Unicorn was

returned to Castle DuRhone where it once more gathered its power for when it might next be needed.

And the story continues...





©2009 LAIRE



## A Walk Through Avalon

Avalon is the capital city of the duchy of the same name, located in the Southern Reaches of civilized Midlantia. Avalon was once a vassal state of the Empire of Nymidia until the Catastrophe. Here many walks of life come together, braving the dangers and reaping the rewards that come with living so close to the edge of uncivilized lands. The city itself has a population of about 2000 families of a variety of races and beliefs and the ducal forces. Life in Avalon can be best summed up as “exciting, if not deadly.”

## The Nobility of Avalon

Once a month, the Duke of Avalon calls his nobles to council and though attendance is not required, many come, especially the high nobles. Many people gather at these times for various reasons of their own, swelling the population of Avalon for the three or four day long meetings.

### Prince Jerrin Dragonheart

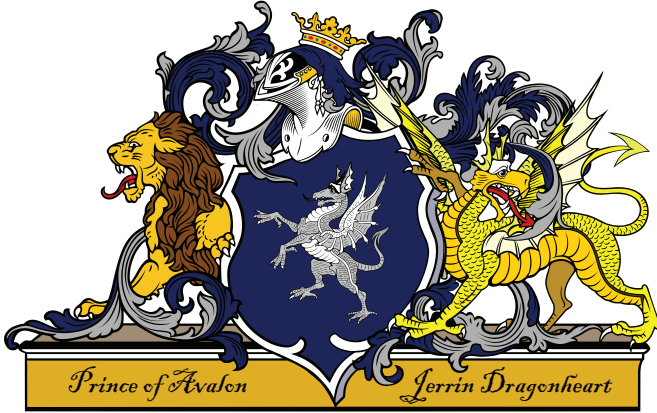

Probably the most enigmatic figure in Avalon is her prince. The prince rules Avalon from the Ducal Castle in the City of Avalon. Rarely is he seen by the common folk. Instead he rules mostly through the Duke, the Chancellor and other high nobles of Avalon.

Prince Jerrin is the son of Aleric Dragonheart. He was spirited away soon after his birth by Zakk and Blaize to be raised as the heir apparent of Avalon. None knew of his existence until his return in 1096PI, at which time he recovered the scepter from Castle DuRhone.

### The Duke of Avalon

The highest ranking noble in the Duchy is the Duke of Avalon and he answers only to Prince Jerrin Dragonhart. All other nobles have sworn fealty to him, either directly or through their own liege lord. His seat of power is the Ducal Castle, which was finished in the year 1104PI, and sits in the middle of the City of Avalon.

There have been many dukes of Avalon in the past fifteen years.

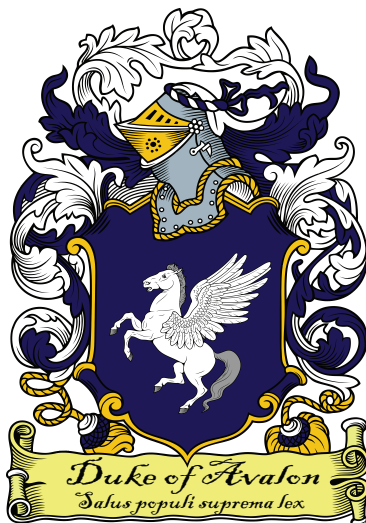

The role of Dukes since 1093 is:

- Duke Sir Kendrick Monaghan 1103 – ???
- Duke Sir Molin Hearst 1099 – 1103
- Duke Kyle DuRhone 1098 – 1099
- Duke Jerrin Dragonheart 1097 – 1098
- Duke Sir Derrik Ironheart 1096 – 1097
- Duke Zakk Swansong and Duchess Blaize DuRhone 1093 – 1095

The Duke of Avalon does not run the Duchy alone. He has his High Nobility, Lord Chancellor, Warlord, Ducal Knights, High Inquisitor, High Sheriff, and Ducal Guard.

The ranking of common nobility of Avalon is as follows,

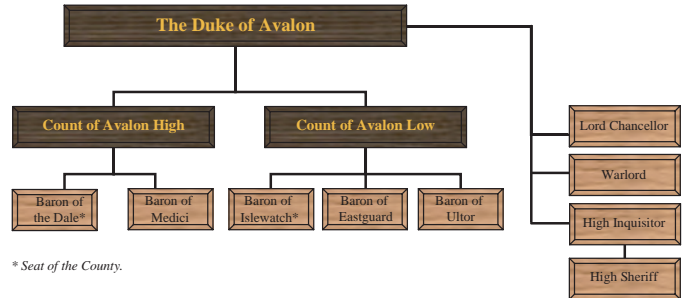

\* Seat of the County.

## The Guilds of Avalon

There are several officially sanctioned guilds in the Duchy of Avalon all of whom have their guildhalls in most major towns and cities of Avalon. The Guild Master of each guild resides in the City of Avalon, from where they control the operation of the guild.

Though some guilds use different nomenclature, the basic guild structure has remained unchanged for hundreds, if not thousands, of years.

The **Apprentice** is the lowest level member in a guild. They are responsible for the menial chores which are only interrupted for a short time for a quick lesson from a teacher. Eventually, however, the industrious Apprentice will find their way to the next level and earn new chores and duties as a Journeyman.

No longer an Apprentice and deserving of some respect, yet not nearly accomplished enough to be called a Master, the **Journeyman** sits apart from the other guild members. While they are not expected to sweep floors and clean dishes, they are expected to devote a large part of their time to helping to run the business of the guild. They have work duties where they spend time selling the wares of the guild, or they may be sent out on errands to acquire raw materials for the Masters of the guild. Sometimes these errands can be most dangerous depending on what guild the character belongs.

When a character reaches a certain level of expertise with their chosen craft, they gain the title of **Master** or a Guild Master. These people are often the teachers and responsible for the important decisions in the guild. They have the most freedom to do as they please and are hardly ever required to spend time dealing with the public and the day to day running of the guild.

Every guild has a **Master of the Guild**, the person ultimately responsible and in charge of the guild. Their decision on all matters is final. Some guilds have a council of Masters to advise the Master of the Guild, but rarely if ever do they have to heed that advice. In their guild, the Master of the Guild is paid the utmost respect by any

who visit and even Nobles of the Realm will tread lightly in the domain of a Master of the Guild.

Not all guilds are created equal. Some hold more sway than others, but all are respected and needed. A guild that serves no function or purpose will fade away. Similarly, not all guilds are run the same way. Tradition and the whim of the Master of the Guild oft times shapes how the guild is run.

The Masters of the Guild sit on the Guild Council and they elect a representative to help settle disputes and act as a liaison between the guilds and the Duke or his representative. Over the years, the stronger, greater guilds have pushed down the lesser guilds until only the greater guilds sit on the Guild Council. The guilds listed below are the members of the Guild Council and currently hold sway in guild matters over the other guilds. The master of any guild can come and petition the Guild Council for any matter and the Council must hear it, but they do not have to side in their favor but often do to maintain the status quo. For example, the master of the Cartwright Guild does not have a seat on the Guild Council, but brings its matters to them when the need arises. The local lords usually take care of most matters and seldom if ever do the lesser guilds petition the Guild Council for much.

### **The Healers' Guild**

The oldest guild in Avalon and even in this region of Midlantia; the Guild of Healers is perhaps the most important guild of Avalon. Not only can one be healed of almost all their ailments here, but should the unthinkable happen and one dies, their person can be resurrected on this Guild's consecrated ground.

### **The Guild of Arcane Lore**

The guild, while new in its present incarnation, is not new to Avalon. In the year 1106PI, His Grace, Duke Sir Kendrick ratified this new guild formed from the old Sorcerers' and Mages' Guilds.

The Guild of Arcane Lore includes mages of all types and practices; from masters of low magic to practitioners of sorcery, warlockery, and spell singing. Indeed if ever there was a question about magic, this guild is the place to go to find out.

Adventurers can come here to find scrolls, spell defenses, rituals, and warlock augmented defenses and permanent magic items. Some of these services do not come cheap but many are within the means of the newest of adventurers.

Besides just the sale and purchase of goods, the Guild of Arcane Lore is a place of learning and anyone who wishes to learn low magic, sorcery, warlockery, or almost any arcane skill or lore can come here to be taught. Nothing is for free, and those interested should seek out the Guild Masters to learn what is expected.

### **The Armorers' Guild**

Avalon can be a very dangerous place especially if one wanders from the relative safety of the city into the dangerous corners of this land. Therefore, most choose to arm themselves with weapons, shields and armor before venturing forth. The Armorers Guild is the place to go for such wares. The forges of this guild almost never grow cold and someone is almost always hard at work making the arms and armor needed by the citizens of Avalon.

The Masters of this guild are skilled at making weapons and armor of quality that resist breaking in combat or are sharper and well balanced. One can also find weapons made of strange alloys here that can be used to defeat some of the more dangerous foes faced in the world.

### **The Alchemists' Guild**

Potions of every kind, solutions of exotic substances and a poison for every occasion can be purchased or commissioned here. People who delve deep into the mysteries of the arcane science of Alchemy practice their art here. Adventurers can purchase Potions of Healing and Giant Strength, oils that enhance their armor and weapons and poisons to quickly take down their foes.

The Master Alchemists generally guard their secrets well and learning how to make these things usually requires admittance to the guild and a formal apprenticeship with a Master.

### **The Merchants' Guild**

This guild's primary function is transportation of goods from one place to another, from one barony to another, or one country to another. They are the buyers and sellers of all things. They also have close ties with other guilds from other countries and lands and use these relationships to transfer goods to those who need it. They produce nothing, but they do have a large assortment of wares for the adventurer to buy, albeit at a slightly higher price.

If you need something and cannot find it in one of the other guilds, chances are you can find it at the Merchants Guild.

Being merchants, they will buy almost anything from anyone and re-distribute it to those who need it, no questions asked.

It is said that this guild has ties to the syndicates in Coventry and their vast holdings and trade routes make them very rich and powerful, indeed.

## **Other Organizations**

Besides the guilds of Avalon, there are other groups recognized and sanctioned by the rulers of Avalon.

### **The Druids' Circle**

The Followers of the Mother have their own organization called the Druid's Circle. The majority of the Druids and Protectors in Avalon belong to this circle, but there are always a few who have decided not to join or who are members of a circle from outside Avalon. The circle is lead by one individual, usually appointed by their predecessor, but sometimes a member will challenge for the right to lead the circle.

The Druids meet at their sacred circle of trees, called the Druid's Grove, which lies on the outskirts of the City of Avalon. This grove has been sanctified to the Mother and is maintained by her followers. The Druids meet here and perform their services to the Mother regularly.

### **The House of the Sun**

Within the City of Avalon and other villages, towns and keeps across the Duchy can be found holy places dedicated to the High Lord called the House of the Sun. These places, all built in the fashion of small stone keeps, have been sanctified to the High Lord and maintained by the Acolytes of the House of the Sun who dwell there. They are all open to everyone as a place of devotion and refuge from the dangers of the world. Their doors are always open to the poor and needy as a place to find shelter and food. Indeed, each House of the Sun runs a soup kitchen, providing food to those who cannot afford to feed themselves.

In the City of Avalon one can find the largest of these Houses of the Sun and it is frequented by many of the Followers of the Light and heroes of Avalon who seek to commune with the High Lord or just

meet their fellows when they come to the City of Avalon during their visits there.

### The Order of Paladins

In Avalon, the majority of Paladins belong to the Order of Paladins. These staunch defenders of the people of Avalon are well known for their heroic deeds. All members of the order are members of the Paladin Council and one member is chosen as their leader. This order has other rules and laws they require their members to follow in addition to the laws set down by the High Lord.

### Necromancers “Guild”

While the crown may realize that this criminal organization exists, it is neither officially recognized nor sanctioned. Hearsay and rumor abounds about this “guild.” Some say there are but a few members with any power and the rest are weak lackeys, others say there are large numbers of necromancers that are hiding within Avalonian society and still larger, more powerful ones in the unpopulated areas of the wilderness, creating large undead armies. The truth is probably somewhere in between.

The Necromancer’s Guild is a secret organization and they do a good job of keeping their secrets. Nothing is known about how their organization works or what ties to other malevolent organizations they may have.

### Cult of the Cryptic Shade

This criminal organization lives in the Dark Wood and is believed to serve Azeroth, the Cryptic Shade himself. This group of nihilists and anarchists believe in bringing about the end of the world in service to their master. They are adept at hiding the identity of their leaders by working in independent cells. They are a fanatical group, most member willing to sacrifice themselves for their cause or sometimes, no reason at all. It is believed several members of the cult living amongst Avalonians, some may even be nobles or heroes...



## Common Laws of Avalon

The laws that apply to the common citizen of Avalon are called the Common Laws or the Duke’s Laws. Every citizen of Avalon and visitor is expected to abide by these laws.

By order of the Rightful Rulers of Avalon, the following are the common Laws of the land known as the Duchy of Avalon, here forth set in to protect Her citizenry.

These Laws are to be obeyed by all common citizens of the Duchy and all common visitors to this land. The Nobility of Avalon and all duly recognized Noble Visitors must adhere to the Laws as set forth in the Codex Nobilis.

These Laws are to be enforced by the Nobility and their duly appointed representatives through adherence to the Rules and Procedures set forth herein.

The minimum and maximum penalties set forth here in are set forth by the Ducal Seat. The judge does have the discretion to exceed these limits if the crime warrants.

Ignorance of the Law is not a defense.

1. All persons must pay proper heed and respect to those whose station is above them. These persons shall include the Nobility of Avalon, Squires, Seneschal, Inquisitors, Magistrates, and Sheriffs. The failure to do so is proscribed.

<b>Penalty:</b>	<b>Minimum:</b>	<b>Maximum:</b>
	Public Apology	1 Death

2. All persons, regardless of their station, have the right to peaceful existence. It is a crime to force one’s will upon another person by force of arms, magical conjuration, or any other means available. These means include, but are not limited to: Thaumaturgy, Charms, and Hypnosis.

<b>Penalty:</b>	<b>Minimum:</b>	<b>Maximum:</b>
	Fine of 5 Silver Pieces	2 Deaths

3. All persons have the right to bear witness against another person when judgment needs be passed over an occurrence of injustice. However, bearing false witness in such matters is proscribed.

<b>Penalty:</b>	<b>Minimum:</b>	<b>Maximum:</b>
	Fine of 1 Silver Piece	1 Death

4. All persons are proscribed from committing Acts of Necromancy. Such Acts include, but are not limited to:

- Casting spells from the School of Necromancy, be it from personal knowledge, scrolls, magical items, or artifacts.
- Necromantic Sorcerous Rituals.
- Necromantic Warlock abilities or rites.
- Necromantic skills or innate abilities.

<b>Penalty:</b>	<b>Minimum:</b>	<b>Maximum:</b>
	Mandatory removal of all Necromantic Items.	Death and Banishment
	Mandatory Indefinite Imprisonment until knowledge of Necromancy is removed.	

5. All persons must pay tribute and taxes to their liege lord. Failure to do so is proscribed.



- Penalty:** **Minimum:** **Maximum:**  
Fine of twice all taxes owed      Imprisonment for 3 Moons
6. All persons must muster to the call-to-arms when summoned to serve to the fullest extent according to their skills and abilities. Failure to do so is proscribed.
- Penalty:** **Minimum:** **Maximum:**  
Fine of 1 Silver      Banishment for 3 Moons
7. All persons are proscribed from committing acts of Treason. Treasonous acts include but are not limited to:
- The making of any Oaths, Obligations, or the sharing of intelligence that will lead to the willful detriment of Avalon or its peoples.
  - Attempting by overt or covert acts to overthrow or displace the rightful rulers of Avalon.
  - To kill or injure the rightful rulers of Avalon.
  - To act in any way that is not in the best interest of Avalon or its peoples.
- Penalty:** **Minimum:** **Maximum:**  
1 Death      1 Death and Banishment
8. All things contained within the Duchy of Avalon are the personal property of the Royalty of Avalon and their heirs. Only by special writ from the Royal House can any other measure of property be established.
9. All persons within the Duchy of Avalon are considered freemen. The keeping, trading, transporting, or in any way engaging in acts of slavery is proscribed.
- Penalty:** **Minimum:** **Maximum:**  
1 Death      1 Death and Banishment
10. All persons are proscribed from committing acts of theft.
- Penalty:** **Minimum:** **Maximum:**  
Twice the value stolen      1 Death and Banishment
11. The Law is the province of the Royal Household and the Nobility of Avalon. The act of taking the Law into one's own hands is proscribed.
- Penalty:** **Minimum:** **Maximum:**  
Imprisonment for 1 Day      2 Deaths
12. All persons are proscribed from committing acts of murder.
- Penalty:** **Minimum:** **Maximum:**  
Fine of 1 Gold      2 Deaths and Banishment
13. All persons are also required to bear witness according to proper rules and procedures. Failure to do so is proscribed.
- Penalty:** **Minimum:** **Maximum:**  
Public Apology      Equal Punishment to the Accused
14. Worship, being a follower of, or support of the Dark Lord or its minions is proscribed. This includes, but is not limited to: Dark Paladins, Dark Clerics, Dark Sorcerers, Dark Acolytes, and their ilk.
- Penalty:** **Minimum:**  
2 Deaths and Banishment
15. To willfully obstruct any investigation made by the Nobility or their duly appointed representatives is proscribed. This includes but is not limited to: destroying evidence, killing witnesses, withholding evidence, and harboring fugitives from the Law.
- Penalty:** **Minimum:** **Maximum:**  
Fine of 1 Gold      1 Death and Banishment
16. Entry into the Darkwood is strictly forbidden. The damage to human life and property caused by disturbing the Darkwood will determine the severity of the penalty.
- Penalty:** **Minimum:** **Maximum:**  
Fine of 1 Silver Piece      1 Death and Banishment
17. The creation, leading, participating, or support of any group, guild, order or organization that persecutes, harasses, attacks, defames, or oppresses any lawful race, group, guild, or order is proscribed.
- Penalty:** **Minimum:** **Maximum:**  
Fine of 1 Gold Piece and Imprisonment for 1 Day      1 Death and Banishment

## Codex Nobilis

The laws that apply to the nobility are called the Codex Nobilis (“The Book of the Noble”), also called the Mores Nobilitis (“The Behavior of the Nobility”). The Codex Nobilis was written in ancient times, and has been handed down through generations of nobility, virtually unchanged.

Let all those who bear the burden of noble blood know that these are the rules of the behavior of the nobility. Those nobles who do not obey them and who do not keep them close to their hearts are not truly noble. Those nobles who fail to respect the noble code are not true nobility – a pox upon the realm whose rulers ignore the law. Those lords who turn a deaf ear to the obligations of chivalry shall command no loyalty – no oath sworn to them shall be true, no task they order shall be obeyed, and no battle in which they lead shall be won. The chivalrous noble who clings to the law despite all hardship and loss shall be honored forever. The pretenders to royalty who eschew these laws shall be cast aside and forgotten.

Thou shalt swear fealty to thy liege lord, and uphold all convictions that are theirs. Defend the honor of thy liege as if it were thine own – brook no evil that would be spoken of them. Truly, there is no greater honor than to offer up thine own life defending thy liege lord. Thy liege is thy parent, and thou must honor them as thou would honor thy mother and thy father – yea, with even more honor, for while life flows from thy natural parents to thyself, life flows from your liege to both thyself and to the land and to thy fellow vassals that thy liege commands.

Stand by the words and deeds and laws of thy family, and be loyal to them, as they are loyal to thee. Dishonor not thy family, nor lead them to dishonor. If thou dost commit a shameful act, the dishonor is shared among thy parents, and thy siblings, and thy children, and they must make amends for thy misdeeds, as thou wouldst in turn make amends for theirs. Therefore, stand always on the side of right and honor, and may thy family always stand with thee.

Do not consort with the enemy, either with thine own enemies or the enemies of the realm. Thy liege lord's enemies are thine own. Stand by the side of thy liege as they face their enemies, and leave not their side, unless commanded to do so, lest thine abandonment of thy post lead to the defeat of thy liege. A noble who hath

abandoned their liege or their people to the desires of their enemies hath also abandoned their honor and their soul. Thou art the commoner's protection against the evils of the world, so that the common folk may work, toil, and sweat to perform their duties. If thou art not a true guardian of thy people, then they cannot and will not labor for thee.

Thy word is thy bond. The noble who makes a promise and then breaks it, the noble who swears an oath and fails to fulfill it, is beneath contempt and deserves not the privilege of nobility. A noble is obliged to stand by their word, even to a vow made to a commoner. If thou doth swear an oath to one, and swear another oath to another, and the two oaths be in contention with one another, then thou art of necessity forsworn. But if a noble stands in the light of justice, righteousness, and chivalry, then there will be some way to preserve both oaths and hence thy honor and dignity. Only one who is not in the right can be forsworn.

Defend the realm from all enemies, be they from outside the realm or within. Never surrender before the enemy, though thou are overwhelmed and certain to be defeated. The keystone of the code of chivalry is that the one who is in the right shall always prevail in the end against the dishonorable, the shameful, the outcasts, or the wicked. Even if thy foe outnumbers thee and is overwhelmingly powerful, if thou art in the right then, at the final battle, thou must be victorious. If thou failest to defeat thy enemies ere the last battle is over, then thou wert not in the right.

Finally, and most importantly, there be only one reason why nobility exists, why they are given such benefits and burdens, such laws and responsibilities, such power and such glory – to champion the cause of right and justice and to defeat the minions of evil and dishonor, to defend the innocent and weak against the mighty and baneful. Never falter in this task, never cease the struggle of right against wrong, for though it may take ten thousand years, the righteous and true noble shall always prevail.

#### **The Treatment of Commoners and Vassals**

As thy liege lord is thy parent, the common folk are thy children. Thou shalt defend the common folk as thou wouldst thine own offspring, for truly they are as necessary to thy life and to the realm as the very air that thou breathest. Thou shouldst brook no disobedience from the commoner, but punish them no more harshly than proscribed by the laws of the realm. The common folk have sworn an oath of fealty to thee, so treat thy obligation to them with no less solemnity.

The common law constrains thee as much as it does the commoner, not in obedience to it, but in the enforcement of the law and in the punishment of those who disobey it. Administer the common law fairly and justly. Use wisdom and forbearance, deliberation and temperance, as thou doth make thy rulings and declarest the appropriate punishments. Let thy sentences for the breaking of the common law fit the degree of criminality, venality, and intent of the lawbreaker. Yield not to the temptation to administer punishment for the pleasure of thyself, for thy fellow nobles, or for the common populace. Do not torment the innocent for the sake of the guilty, nor allow the guilty to escape judgment for the sake of the innocent.

#### **The Laws of Hospitality**

Between a woman and a man, there is no more solemn oath than the vows of matrimony. From a vassal to a noble, there is no more important an oath than the oath of fealty. And for the noble or commoner who is master of castle or keep, home or household, there is no more sacred an obligation than the oath of a host to

their guest, or the respect that a guest owes to the master of the place in which they partake of a table, a roof, and a bed.

If thou doth offer hospitality to a visitor, and they do accept, then thou must treat the visitor as an honored guest. Thou art obliged to guard and protect them and keep them from harm for as long as they stay under thy roof. Likewise, thy guest is obliged not to abuse the hospitality that thou hast offered. They may cause no harm against any member of thy household, nor speak harsh word against thee, thy household, nor any other guests under thy roof.

Woe betide one who violates the laws of hospitality, for they shall never know peace, nor rest, nor justice under their roof nor under the roof of anyone else, lest and until they make full wergild for their dishonorable deeds.

#### **The Honor Duel**

Should a dispute arise between one noble and another, or between one commoner and another, and no other means of recourse be available to resolve the dispute, then they may settle the dispute by means of a duel of honor. The victor in an honorable duel shall be the one who is in the right, in accordance with the laws of chivalry.

In ancient times, people believed might made right and points of law and politics were settled with an honor duel. In these more enlightened times, honor duels are only fought over points of personal honor, never over the law. Should any person feel they have been wronged by the judgment of a person of higher standing, the proper recourse is to find a noble of higher standing to appeal their plight and champion their cause.

A commoner can challenge a noble and a noble of lesser standing may challenge a noble of higher standing to a duel. A commoner or noble may challenge one of equal standing as well. A noble shall not issue challenge to a commoner, nor to a noble of lesser degree than themselves – it is not just that a noble should use an honor duel to punish or chastise one of lesser station.

A duel of honor must proceed in this way – one of the parties involved in the dispute must challenge the other. The challenger must be able to state the reason for the challenge, and state the issue to be decided by the duel. The challenged, if they deem the matter worthy of a duel, and if the consequence of the duel is acceptable to them, may perforce answer the challenge. Should the challenged accept the duel, they have the choice of weapons, including but not limited to martial arms, mystical forces, or a test of pure will – if the challenged feels bold enough, they may open the contest to any and all weapons by either duelist.

Both the challenger and challenged then appoint seconds. The seconds arrange amongst themselves the time and place and rules for the duel. If a combatant in the duel is unable to attend – perhaps because they have been slain and no member of their family is available to take their place – then it is the duty of the second to fight the duel in their stead.

A duel must be fought and conducted honorably. If there is any hint of dishonor, any sign that one of the combatants is cheating, then the other combatant is declared the victor.

## The Code of Chivalry

Below are the laws of Chivalry. Every noble must aspire to follow all of these to be truly called noble.

- Thou shalt love thy country thou hath made thine home and not surrender to thine enemies. Thou shalt be loyal and known for thy unwavering commitment to thine people. Thou shalt perform loyally thy feudal duties, if they be not contrary to the laws of the land. There are many places where compromise is expected; loyalty is not amongst them.
- Thou shalt live ones life so that it is worthy of respect and honor. Thou shalt never lie and shall remain faithful to thy word of honor. Thou shalt always carry thyself with the decorum, dignity, and seriousness of thine station and responsibility.
- Thou shalt be courageous and be prepared to make personal sacrifices in service of the precepts and people thou doth value. Thou shalt take the side of truth in all matters, rather than seeking the expedient lie. Seek the truth whenever possible, but remember to temper justice with mercy, or the pure truth can bring grief. Being a true noble often means choosing the path of courage, the more difficult path, the personally expensive one.
- Thou shalt value first the contributions of others. Do not boast of thine own accomplishments; let others do this for thee. Tell the deeds of others before thine own, according them the renown they have rightfully earned through their virtuous deeds.
- Thou shalt be generous in so far as thine resources allow; largesse used in this way counters gluttony. It also makes the path of mercy easier to discern when a difficult decision of justice is required.
- Thou shalt be everywhere and always the champion of the right and the good against injustice and evil, unencumbered by bias or personal interest. Recognize that the sword of justice can be a terrible thing, so it must be tempered by humanity and mercy. Thou shalt seek justice without bending to the temptation for expediency. In this way, thou wilt earn renown beyond measure.
- Thou shalt respect the weak and innocent and shalt count thine self as a defender to them. Thou shalt protect women for they are delicate, weak and in need of protection. Thou shalt protect children for they are innocent and helpless.
- Thou shalt uphold thine oath to defend thine liege lord and those who depend upon thee. Seek always to defend thine country, thine family, and those worthy of loyalty.
- Thou shalt never attack an unarmed foe and use excessive force on a foe unworthy of thy might. Thou shalt always give quarter when asked from an honorable foe.
- Thou shalt seek excellence in all endeavors expected of a noble, martial, magical, and otherwise; seeking strength to be used in the service of justice, rather than in personal aggrandizement.
- Thou shalt have faith in thine beliefs, for faith roots thee and gives thee hope against the despair that human failings create.

## Rules of Etiquette

The following rules of etiquette for commoners were prepared in order that the common folk should know how to address their betters.

To greet a fellow commoner, a handshake is appropriate. If the need to use a formal title arises, address a gentleman as “Master” and address a lady as “Mistress”. For example, one would say “Master Arthos” or “Mistress Trakken”. Only a boor or an oaf would use the inelegant title of “mister” or “misses”. “Miss” is occasionally acceptable.

To greet a Lord or Lady of the realm, incline your head in a bow. Address them as “Lord” or “Lady”, “My Lord” or “My Lady” is also acceptable. A bow of the head is also sufficient to greet a Knight of the realm. Address a Knight as “Sir” or “Dame”.

To greet a Baron, Baroness, Earl, Count, or Countess, bow from the waist. Since a Count or Countess ranks higher than a Baron or Baroness, you might be inclined to bow more deeply before the former than the latter. Address a Baron or Baroness as “My Lord Baron”, “My Lady Baroness”, or “My Liege”. Address a Count or Countess as “My Lord Count”, “My Lady Countess”, or “My Liege”.

To greet a Duke or Duchess, kneel or curtsy. It is not necessary to lower your head as you do so; such a greeting would be reserved for a Prince, Princess, King, or Queen. Address a Duke or Duchess as “Your Grace” or “My Liege”.

At the present time, Avalon does not acknowledge any noble with a title of King, Queen, Emperor, or Empress within the realm. Should you travel outside Avalon and meet such an august personage, do a full bow or curtsy, including a full lowering of the head. In the case of an Emperor or Empress, you should do this at least twice, perhaps three times. A Prince or Princess is addressed as “Your Royal Highness”, a King or Queen is addressed as “Your Majesty” or “Your Royal Majesty”, and an Emperor or Empress is addressed as “Your Majesty” or “Your Imperial Majesty”.

When addressing nobles from a foreign land who are visiting Avalon, it is improper to pay them undue respect. You should never just kneel to someone who claims to be a King of some unknown land. This does not apply to recognized nobility from other lands. These personages should be paid all due respect their station implies. One should never kneel or bow or pay any other type of obeisance to a noble from an enemy or hostile land.

It is only necessary to bow or kneel once per day upon meeting a noble, unless they request otherwise. Additionally, before you bow or kneel you make sure you are within comfortable speaking distance and in front of the noble, only a buffoon would kneel fifty yards behind their Duke and expect to be recognized. When kneeling, you should remain so until ordered to rise.

There are a few times when it is acceptable not to kneel or bow to a noble. First is when you are engaged in combat or part of a general melee. Wait till you have the field before making your obeisance. A person on active guard duty should never put themselves at a disadvantage by kneeling to an approaching noble; you do yourself and your liege lord a grave disservice doing so.

## Economy

The basic coin of the realm is the copper piece, often abbreviated cp; a copper piece will buy you a meal at a typical tavern. Ten copper pieces is equivalent to one silver piece (sp); a silver piece will buy you a room at a typical inn for one night. Ten silver pieces is equivalent to one gold piece (gp); a gold piece will buy you room and board at the fanciest hostel in Avalon, the Five Lions Inn.



## Calendar

---

These are the holidays celebrated in Avalon each year:

**January 1 – First Day of the Year.** The festival of Firstday is held on this day; this holiday does not celebrate the first day of the year, but the first day of independence for the Duchy of Avalon.

**February 2 – Mage’s Day.** This holiday is for the honoring of spellcasters. It is considered good luck for a spellcaster to give the gift of a spell to a stranger. Those who can afford it buy magic scrolls to give as gifts.

**February 29 – Dragon’s Day.** On this day, a community is supposed to offer a gift to the dragon that lives closest to their town, in gratitude for not being eaten. Since dragons expect expensive gifts, most communities can only afford to give a gift once every four years, which is why the holiday is held on the leap day.

**March 21 – Healer’s Day.** On this day, those who can cast healing spells and who can restore people to life are honored. If someone has cast a Heal Life or Return Spirit spell during the past year, or is invested in a Healers Circle, it is considered an honor to invite them to dinner. Traditionally, the Healers Circle charges no fees for those who are resurrected on this day.

**April 1 – Rogue’s Day.** This is a day of tricks, pranks, and practical jokes. On this day, minor infractions of the law are forgiven, and people are supposed to take small personal losses with good humor. Traditionally the Thieves Guild returns all the items that have been stolen by their members since the last Rogue’s Day; nothing is ever returned, of course, which again proves that there is no Thieves Guild in Avalon.

**May 1 – Warrior’s Day.** This is a spring festival, with maypole dancing, parades, and feasting, all to honor the warriors who defend the land from its enemies. This is considered a good day to hold tourneys, and for the nobility to knight those squires who have proven themselves worthy of the honor. There is a tradition that everyone must give in to any romantic request that a warrior makes on this day; there is another tradition that says that only the warriors believe in the first tradition.

**June 21 – Sorcerer’s Day.** This day the sorcerers, masters of High Magic, are honored. This day is considered a good time to cast complex and ambitious rituals.

**August 1 – Assassin’s Day.** On this day the people of Avalon lock themselves in their homes and bar their windows. They do not know what goes on during the Assassin’s Day celebrations, and they do not want to know. Probably nothing happens, but it is better not to take any chances.

**September 21 – Harvest Day.** By this time the harvest has been completed, and so this is a day of feasting and celebration. The common farmer is honored on this day; even the nobility of Avalon will bow to the humble peasant who supplies them with the food they eat.

**October 31 – All Hallow’s Eve.** On this night, mysterious mystical energies flow over the land, evil creatures stir, strange beings walk the night, and darkness is to be feared. In other words, it is like every other night of the year in Avalon. It is considered to be a good night to hold costume parties and celebrate because of the solemnity of the following day.

**November 1 – All Hallow’s Day, also known as Paladin’s Day.** On this day, all those who have fallen in the defense of the land during the past year are remembered. Traditionally, people are

supposed to be solemn and sober on this day, as they recall those brave defenders who they will never see again. There is a small ceremony where the names of the honored dead are read aloud in the town square, so that their memories will never be forgotten.

**December 21 – Yuletide.** This is Yule, a traditional festival that anticipates the return of spring. There is much feasting and merry making. This is also the day the nobles reaffirm their oaths to their liege lord and many new nobles are made.

**December 31 – Alchemist’s Day.** Traditionally, alchemists time the brewing of their most exotic potions so that they’ll be completed on this day. People give gifts of alchemical items to celebrate a successful and happy year to come.

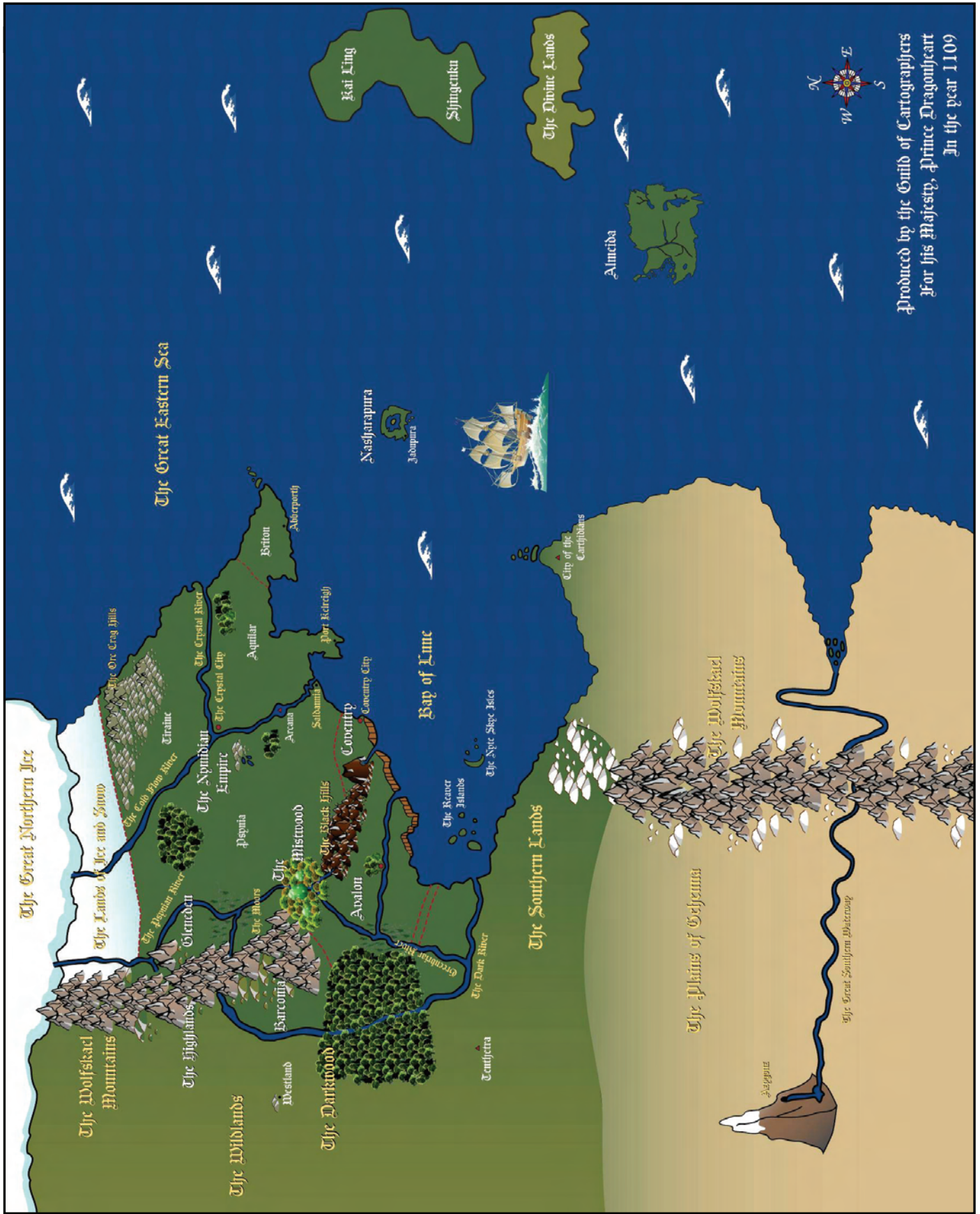

Produced by the Guild of Cartographers  
 For His Majesty, Prince Dragonheart  
 In the year 1109

## The Realms of Midlantia

### The Old Nymidian Empire

Nymidia was the largest single territory in the lands of Midlantia. It was ruled by an unbroken line of Emperors or Empresses for thousands of years. As with most societies that clung to a singular lifestyle for long periods of time, theirs was a corrupt and degenerated culture; existing on the labor of others and had many vices. The last Empress, Valna I, fed on cruelty and injustice. Indeed, her malice was so great and her power so terrible that she plotted to ascend herself to godhood. To this end, she began a great ritual that was to take her a year to complete had not the heroes of Avalon arrived to stop her. During this year of destruction, Valna killed much of the population of Nymidia and consumed vast numbers of artifacts and items of power.

In the Empire, there were three main groups of people: The True Nymidians as they called themselves, the common Nymidian, and the undead. Valna was not human; she was a race of her own creation. She passed some of her traits onto her issue and they became what are commonly referred to as True Nymidians. Though few in number, they comprised the bulk of the ruling class and over the centuries they grew lazy, capricious, vain, cruel, bored, and most of all decadent; all this brought on by their personal power, wealth and Elf-like longevity. They played games with the common people of the lands, raising some in prestige and power only to dash them down again, turning some into an undead monster to live out existence as an example to any who cared to see. Most however were used as a slave labor force, in actuality if not in name.

The common Nymidians are mostly human, with some people and families able to trace their lineage back to some True Nymidian ancestry. They comprised the vast bulk of the population of Nymidia. Other races could be found in these lands but not to the extent they are found in Avalon today.

Up until 1104PI, the empire laid in ruin and much of its lands lied fallow, haunted by undead creatures, most definitely an unsafe place to travel for even the strongest of adventurers. Within the Empire there were many provinces with a variety of peoples; some are oppressed and some are the oppressors.

### The New Nymidian Empire

In 1104PI the situation in Nymidia began to change. Most of the world viewed this once great empire as just a rotting carcass whose final death throws would take years. Instead, a man of great power, guile, and intelligence assumed the throne of Nymidia by deposing and killing Richard Llewellyn. Then this necromancer rose the empire from the dead.

Over course of five years William Thallman, Demon Knight of Zebulon, rebuilt the Empire of Nymidia and has brought back much of its former glory.

Below is a description of the duchies and major locations of Nymidia, their past and current situation.

#### *The Duchy of Aquilar*

Edmund du'Bois was the decadent Duke of Aquilar. He was well known for his fondness for the fairer sex, and his sword had slain more than one unlucky husband who sought vengeance. The Count was human, and one of the two ranking nobles who were not True

Nymidian. His lands provided fine timber for the Empire craftsmen to work.

During the second great Nymidian war, Count du'Bois held the then Countess Blaize as a prisoner and flaunted his prize in front of Avalon until he was defeated and the Empire driven back days later by the heroes of Avalon.

Aquilar was spared the worst of the fall out from Valna's failed ritual ascension to godhood, but, like the rest of Nymidia, was devastated when the Midguard was raised from the dead. The land was then later ravaged by battles as Tarsus and Llewellyn fought for control of Nymidia.

After Thallman took over Nymidia, peace finally came to the land. The people were indoctrinated into his new order and they began to use undead as cheap labor. The towns and cities were quickly rebuilt and prosperity returned to the land.

#### *The Duchy of Briton*

Briton was home to the birth of the Catastrophe, and was kept under the tightest rein to the end. Baron Roderick Lothar ruled his lands with an iron fist, and it was not unusual to see executions in the streets and large numbers of slaves on the block in this region of the Empire. Slaves worked the fields, tended both flock and crop in this, the smallest of the Empire's provinces.

Stories came out of Nymidia during the time Valna was casting her great ritual of long lines of people being moved from Briton to the Crystal City, supposedly to be sacrificed in her ritual. Other than this, no word came out of this region since the fall of the Empire until Thallman took over. Now it is a great point of contention between Avalon and Nymidia.

Thallman moved his troops into Briton in the year 1108PI and had conquered half of the Duchy before learning of Briton's admission to Avalon. Now Briton is divided into East and West Briton and it stands a hotbed waiting for something to set it off. Baroness Miarianna Freeborn currently rules Eastern Briton from the capitol of Farrington, insight of the Nymidian Empire and the Great Wall that divides the land in two.

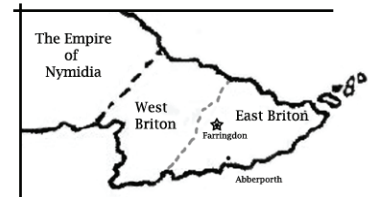

#### *The Duchy of Psynia*

The oldest of the Nymidian provinces, Psynia was once the home of the vast Imperial Armies that conquered the bulk of Midlantia in the golden days of the Empire. Livestock and crops flourished on the lush prairies. Count Colin Draegosian, Brigadier General of the Imperial Host and ruler of the largest Empire province, was said to be the single greatest warrior in the world. Indeed, when Avalon invaded the Crystal City, Count Draegosian was there to meet the Heroes and even after his men fell, the heroes were barely able to defeat him in combat.

After Valna's great ritual was thwarted, a rent in space opened up and a great jungle appeared covering the southern half of Psynia. For about a year, all manner of strange monsters and deadly creatures came from the jungle. Most of the heroes of Avalon escaped through a portal back to Avalon, but the Earl Stewart diMedici, who was leading the army of Avalon, never made it out of the jungle and perished in that alien world.



The jungle did not survive the first Nymidian winter and has since all but disappeared, and was replaced by little else but undead.

But the jungle also left an influx of nutrient rich soil which a decade later would see trees, wildlife, and people return to the area. Psynia was one of the first provinces conquered by Thallman. Psynia had no central government and was ruled by little more than brigands and mobs; a fact that made it easy for Thallman's victory so easy.

Now Psynia is on its way to reclaim some of its former glory. Skilled craftsman and undead laborers work constantly to repair and rebuild the duchy.

### ***The Duchy of Tiraine***

The most Northern Province of the Empire, this cold land was ruled by the Duchess Nèvèia, also known as the Ice Princess. Tiraine was a sparsely populated region known for its wild beauty. They constantly warred with the Barbarian tribes and Ice Elves from the Lands of Ice and Snow over the northern border of the Empire and with the Orcs, Trolls, and Goblins from the Orc Crag Hills.

After the fall of Valna Tiraine turned isolationist and began to fall in on itself. With out the power of Valna and her armies, the lands nobles and their petty conflicts threatened all out civil war. The jungle to their south and then the undead army kept Tiraine from completely collapsing.

Tiraine offered the only real resistance, besides Briton, to Thallman's conquest of Nymidia. In the end, this land capitulated and swore fealty to Thallman. What happened to Nèvèia is unknown, rumors say she still rules Tiraine after Thallman restored her to power.

### ***The Crystal City***

The Crystal City was undoubtedly the greatest city of Midlantia for centuries. Named for the city's crystal spires, it was from here that the Empress Valna I ruled her dominion. It was said that she had a particular hatred for the people of Avalon, for there are many who said that she was the Dark Queen that the Prophecy speaks of. She was a powerful sorceress, which allowed her to maintain control over every corner of the Empire.

After the wars against Valna and the Crystal City, and the backlash of her flailed ritual, the once beautify city was nothing more than a great ruin. Undead swarmed about the place and other kinds of creatures could be found under the ruins.

Now the city is rebuilt and at the heart of it sits the crystal walls of the old castle surrounding the Obsidian Keep of Emperor William Thallman. From here Thallman rules his empire, not with the iron oppressive fist of Valna, but with the soft gloved hand of a benevolent father. The people love and adore their emperor who, rather than enslave and kill them, protects, guides, feeds them. But the emperor is a Servant of Darkness, and while he may show a kind face, evil still lurks under all the gilding.

With his ever growing popularity and power, Emperor William Thallman, Lord of Nymidia, Demon Knight of Zebulon, and The Necromancer may well prove to be as big a threat to Avalon as Valna ever was.

## **Barconia**

Once a strong land that encompassed the land east of the Darkwood along with all the surrounding areas (with the exception of Avalon in the east), the Barconians now inhabit only the lower regions of the Wolfskäel Mountains. They bore great enmity towards both the

Empire and the peoples of Avalon. The Empress once promised to aid Barconia in its efforts to annex the Barony of the Dale in Avalon, but Outlanders overran the area in the early winter of 1092. In the eyes of the Barconians, the Empire then turned its back to them without offering a single man or blade. The vast tracts of Barconian flatlands are now part of the Wildlands, under the control of no one.

Barconia was ruled by petty nobles and robber barons. The lands of Barconia are mostly infertile and only sparsely wooded, making the only real resource stone, of which they have an overabundance. The lands have been politically fractured for a great many years, each barony quietly distrustful at best or openly hostile at worst towards all of its neighbors. This has prevented Barconia from being any real threat to Avalon.

During the reign of Duke Jerrin Dragonheart, the baron of southern Barconia, a scoundrel of a man named Robert the Rough, fell under the control of Avalon when Baron Robert signed a peace treaty with Avalon and swore fealty to the then Duke Dragonheart. Robert the Rough quickly showed his true colors when he used his new found backing to make war against his neighbors. Eventually the nobles of Avalon grew tired of "Baron" Robert's warmongering. Rumors of his support of Necromancers and Dark Paladins eventually brought Avalon and Robert to blows, one fight Robert did not win. The lands of Southern Barconia were annexed as part of Trellhiem and an uneasy truce was maintained with the baronies of northern Barconia.

Recently, Avalon found an ally in Sir Tarrin, a baron of one of the northern Baronies, but the other baronies view Avalonian rule as a threat to their own power and have made many attempts at wresting control of Barconia for themselves.

In the year 1107 the civil war that beleaguered Barconia came to an end when Baron Terrin proved victorious against the True Nymidians who opposed him. The Duke of Avalon returned the lands of Southern Barconia to him after the war. Now Barconia thrives and is recognized as a County under the rule of Count Tarrin and is a strong ally to Avalon. Indeed many of the old hatreds between Avalon and Barconia have grown cold as the people now look at Avalon as friends.

The Knights of Dundrezdon aid Count Tarrin in maintaining peace across the land. They are well respected and honorable knightly order composed of chivalrous knights and Paladins.

## **Free Lands of Coventry**

Lying just north of the Black Hills, Coventry is the only free land that shares a border with the Empire of Nymidia. The people of Coventry are sometimes referred to as the dregs of Midlantia, for nowhere else is there assembled such a vast array of scum, cutthroats, and blackguards or a place of such treachery and duplicity. Ruled by a council of the wealthiest merchants of the Syndicate. They are rumored to have close ties to the pirates of the Reaver Islands. Almost all trade across Midlantia is controlled by the Syndicate and it is this power that keeps this land independent of any of the great powers of Midlantia.

## **The Kingdom of the Elves**

The Mistwood Forest is home to Grey and Wood Elves. The wood itself is a magical place with an almost unnatural beauty. Almost all the resources the Elves could need can be found in the wood. The stories of the magical glades and pure springs are legendary in this part of the world.



The Mistwood is home to Gray Elves and Wood Elves almost exclusively; few other people are welcome in wood for long. The Grey Elves live in the capitol city of Quentis. From here the Queen of the Elves, Yanna NeFay and the Great Council rule the Elven people. The Gray Elves are divided into houses comprised of families and extended families. There are a great number of houses, but only a few of the most powerful hold any real political influence. These head of each of these great houses have a seat on the Great Council. While the Queen has the final say, the Great Council's influence is still great. There are seldom if ever any outward dissensions between the Queen and the Great Council, but the subtle machinations of these powerful nobles would take a human lifetime to understand.

Juxtaposed to this city life and political intrigue is the simple life of the Wood Elves. These Elves live in isolated, small villages throughout the wood. They live content and in harmony with nature leaving the politics to the Gray Elves. They recognize the Queen as theirs own and are as loyal as any Gray Elf.

Quentis lies at the heart of Mistwood and is built around the Great Tree from which all other trees in the forest are said to have been born. The city of Zinfelendin lies at the southern edge of the Mistwood. It is the only place in the Mistwood where outsiders are allowed to come, and only with permission. Through this city all manner of commerce flows into and out of the wood.

Steeped in ancient Elven culture, few who are not wholly Elven have ever seen its wondrous beauty.

## The Dwarves of the Black Hills

The Black Hills are home to Hill and Mountain Dwarves. Though they seem like different races, the Hill Dwarves and Mountain Dwarves say they are one people. The capitol of the Dwarven Nation, the city called Dwarvenholm, is deep under the Black hills to the south. From here the King of the Dwarves, along with his knights and lords, rule the Dwarven people.

The Hill Dwarves live on the surface of the mountains in towns. Near each is an entrance into the mountain and the homes of the

Mountain Dwarves. The Hill Dwarves tend their flock, raise their crops, and produce the crafts they are famous for. Most of these goods go into the mountain to the support the Mountain Dwarves.

Meanwhile, deep under the mountain, the Mountain Dwarves live in cities built in large caverns. There are many dangers underground; Goblins, Orcs, and especially Trolls are frequently found wondering the caves and caverns of the mountains. Deep below the Dwarven realm are even more dangerous creatures. Dark Elves, Kurig, Beholders, and Mind Flayers to name just a few. Many Mountain Dwarves are part of the standing army. A necessity in the dangerous realm. Not all Mountain Dwarves are warriors. Some tend large mushroom gardens, mine valuable metals and minerals, and practice various crafts.

King Kelgar Whitestone, grandson of the famous Olin Whitestone, rules from the fortress city of Dwarvenholm. From there he directs the lords and knights of his realm. All Dwarves regard him as their sovereign.

## The Highland Home of the Highlanders and Celts

The Highlands are a land of stunning beauty, lush green mountain pastures, and crystal-clear lakes in the lower Wolfskæl Mountains. This region is rich with natural resources and fertile farming and grazing lands.

The Highlands are home to the Highlanders, who in 1090PI were driven from their homes by the evil Bainites and their Ogre allies upon losing a long war. Many of the surviving Highlanders found a place of refuge in the Duchy of Avalon. There, the survivors trained and honed their skills until, with the aid of their Avalonian friends and allies, were able to retake their homelands from the children of Baine.

Now free from the Bainites and Ogres, the Highlanders and now their long lost cousins, the Celts, set about the task of rebuilding their homelands and establishing themselves once more.

But the threat of the Bainites is not gone. In recent years, their numbers have grown once more. In the summer of 1108, Bain entered our world and, using the ancient Flesh Forges of the Hierarchs, created the True Ogres. Once more the people of the Highlands are in danger of being overrun.

## The Empire of Telvenden

The Empire of Telvenden, or the Western Empire, was formed roughly 1500 years ago after a Great Cataclysm shook the lands west of the Stormsye Mountains and South of the Whitecap Mountains. The empire contained 20 nations (duchies) along with other territories. For most of its history, the empire was ruled by three emperors who shared equal power and were advised by the Council of Dukes. The onset of the war now known as the Interregnum of Denthnar brought the rule of the triumvirate and the council to a brutal, bloody end.

The empire's nation states contained a wide variety of peoples and races. Each paid the empire an annual tribute and follows certain imperial edicts. They were allowed to follow their own customs and laws, so long as these do not contradict an imperial edict. Each nation was ruled by a duke, who answered to the emperors, and contained its own nobility structure.

Now the Empire is no more. Years of conflict with and defeat by the Heart of Darkness has shattered the empire to pieces. No one is sure what the final outcome will be with this land.

## Other Nations

### *Almeida*

Little is known of this island nation. In the early part of the 11<sup>th</sup> century, several refugees from the Almeida appeared in Avalon. They told a tale of a great necromantic disaster that struck the island turning most of the population into undead.

### *Gleneden/Glenraven*

Often referred to as the Gardens of the North, this lush Barony maintained its freedom by paying massive tribute to the Empire for its protection. Several times in Gleneden's history it was a battlefield for the forces of the Empire and the massed goblin armies from under the Wolfskael Mountains. The eastern slopes of the mountains in Gleneden are home to the Halflings, a furry-footed and jolly race of Little Folk.

When the Midlantian Guard Banner fell and all the old guard rose as undead, these lands were beset upon by hordes of undead. The Halflings saw their doom coming and for once, were not so happy. Then, a clan of barbarians, fleeing the undead, came to Gleneden and together with the Halflings, survived the attack. The barbarians made the lush lands of Gleneden their home and the Halflings enjoyed their company and protection. The Halflings changed the name to Glenraven in honor of their new barbarian friends.

In 1108, the Emperor of Nymidia delivered an ultimatum to Avalon, relinquish the lands of Briton to him or he would destroy Glenraven. True to his word, when Avalon failed to capitulate to his threats, the Nymidian army moved in and destroyed the inhabitants of Glenraven.

### *Nasharapura*

This island nation is the ancestral home of the Kaletani. Ages ago a great catastrophe struck the island and many Kaletani fled to the mainland. Those that remained behind survived.

Descendants of the refugees integrated themselves with mostly human society. Other migrated to what is today the Wild Lands where tribes of Kaletani can still be found today.

In the year 1108, an emissary from Nasharapura came to Avalon to ask for help in defeating the undead that plagued their island. Avalon ventured to the island and discovered a Lich was behind the troubles of the island. The Host of Heroes defeated the Lich and liberated the Kaletani of the island. Now the Kaletani of Nasharapura are rebuilding their society.

After spending so many generations on the mainland, few Kaletani returned to their island. Today, Kaletani can be found living amongst the people of Avalon and other nations on the mainland.

### *The Nyte Skye Isles*

These islands, located far out in the Bay of Lûne, were home to the Loreli Council and the secret of the Prophecy. With the ending of the Prophecy and departure of the Loreli, the islands are now home to the new Spell Singer Council and teachers.

This land was once a mysterious set of islands where few traveled, but now has become open to outsiders and a new nation of diverse people now seeking to develop trade to support their population. These islands have few natural resources of their own and without the power of the Loreli to support them, the common folk have had to learn to fend for themselves.

### *The Reaver Islands*

Home to the Black Skull Pirate Lords of the Great Eastern Sea, the Reaver Islands lie off the coast of Islewatch. Since most of the naval power in Midlantia was destroyed in the Catastrophe, this confederation of pirates is a formidable group in their own element. They are reputed to maintain close ties with the Freelands of Coventry.

Now with the building of the Avalonian fleet in recent years, the pirates face a new challenge for their naval supremacy. There are many small islands in this archipelago, some rumored to hold lost pirate treasure and ancient forgotten places.

### *The Great White Swamp*

Packed tightly between the Darkwood and the Barrowdowns, the Great White Swamp is the realm of Herpata Nomana, the Queen of Snake Island. Some say that the Queen is human, but her court is full of snakes, saurian, and other water-dwelling creatures. Her subjects are neutral in attitude towards the inhabitants of Avalon, although monsters sometimes wander out of the swamp.

These swamps are home to the Saurian and Lizardman people who often come in territorial conflict with each other. The swamp is a dangerous place to visit, not only from the natural hazards of peat bogs and quicksand but from the dangerous monstrous creatures that dwell within this swamp. But rumors of fabled treasures and lost ancient ruins always lure the bold adventurer into these hazards; some meeting their end with an encounter with mating Vipermen or disappearing into the boggy waters never to be seen again.

### *The City State of Tenthetra*

After the defeat of the Carthidians, many of the former slaves and commoners came to settle here in the City of Tenthetra. The city has steadily grown over the years and holds close ties to Avalon. It is ruled by the Seneschal.



## Significant Places

### *Arcana*

The island of Arcana is the pinnacle of magical knowledge in Midlantia. Isolated by the frigid waters of the Cold Flow River in the former Empire, this college of mystical knowledge is used by all races and nations on Midlantia. Ruled by the Council of Three, there is much political maneuvering done within its walls and towers. Entrance here is not easily granted, and passage through the lands of the former Empire is not guaranteed.

### *Azygoüz*

Few travelers have made the journey to the Great Mountain without magical transport, and even then, precious few have returned. Azygoüz is said to contain great magical secrets, but also dire monsters.

### *The Black Hills*

The Black Hills form the border between Coventry and Avalon, and contain several mines and mining towns. They are considered unsafe for travel after the Troll Uprising of 1090. Most of the human miners have left, but the dwarves mine on, heedless of the danger. Monsters now roam freely in the Hills, but seem reluctant to move outside them, except under the cover of darkness. The Psynian River splits in the Mistwood, and the northern branch runs under the Hills to exit at a great waterfall into the Bay of Lûne.

### *Castle duRhone*

Sitting high on the cliffs in Islewatch, this was the home of the Dragon Blaize duRhone, the daughter of Eldin duRhone and Countess of Islewatch for great many years. To this day, even with the passing of Blaize, the castle remains only truly safe for a duRhone.

The castle is said to be a mysterious place, for some tell of demons and elementals that fetch and serve, while others swear that they see things out of the corner of their eyes, but can never tell exactly what those things are. There are stairways that go nowhere and doorways that lead to different places. People have been lost for long periods of time, wandering a seemingly endless maze of corridors, rooms and passages.

This is not a place for the casual visitor and one should only go there when invited.

### *Darkwood*

The Darkwood is located to the east of Avalon, along the borders of both Medici and the Dale. This black forest exudes an aura of evil, and makes those who pass close to it uneasy. It is said that the Cult of the Cryptic Shade has a city within the Wood. Of those who have ventured into this evil place few have left, and those who did have no memory of the events that transpired within. Tales of living vampire trees and other such stories are often used to frighten small children into the proper behavior, but some of these rumors are based in truth. The River Underdark, a river of blackened water, runs through the Wood.

### *The Great Northern Ice*

This glacier is at the top of the world, and is said to be growing. Strange glows often come off the Ice at night, but none have made the trek to investigate.

### *The Lands of Ice and Snow*

This cold land, covered in snow and ice most of the year lies south of the Great Northern Ice and north of the former Nymidian Empire. This region is home to the Northern Barbarian tribes and Ice Elves. Few natural resources, animals and plants can be found here making this region desirable only to its two current inhabitants. Being so far away from most civilized lands, this region may very well hold hidden places for adventures to explore, if they are willing to brave the harsh land and violent people.

### *The Plains of Gehenna*

The Plains of Gehenna, a vast region south of Avalon and covering most of the southern part of the continent, are dry most of the year. It is a land of nearly infertile savannas dotted with deserts. The weather is not the only hazard in this harsh land. Anti-magic storms rage across the land destroying all magical items and draining magical energies from anyone who has them. It is these storms that have shaped the Outlanders, a race of barbaric people who inhabit the region.

There are many stories of the Carthidian Empire, an ancient civilization much older than the Nymidian Empire that once occupied this area but met its doom a great long time ago. In 1104, a number of Carthidians magically returned to their old land and raised an ancient city on the eastern portion of the Plains, far away from the anti-magic storms. This region has more arable lands which the Carthidians have begun to cultivate.

### *The Underdark*

Of all the regions of Midlantia, the Underdark is the most unexplored and for good reason. First, it is said that the Underdark spans the entire continent and on many levels, making it almost impossible to map or fully explore. Comprised of vast tracks of natural and crafted caves, tunnels, and passages, the Underdark may always remain a mystery.

Chief denizen of the Underdark, at least the most infamous, are the treacherous and deadly Dark Elves. The exact location of Tenebrous, the capitol city of the Dark Elves, is unknown.

Many other bizarre and strange creatures can be found in the depths of the Underdark and only a brave group of adventurers should dare enter where the sun never shines.

In the deeper dark, an area even deeper than the Underdark, lives the Beholders and Mind Flayers who have been locked in a great war of as long as any one can remember.

Recently, an ancient race of dwarves, the Kurig, have been discovered living in the deep dark. Locked away for eons, the Kurig have once more surfaced. As the Dark Elves serve Arachnia, so too do the Kurig serve Pid.

### *The Wolfskäel Mountains*

The greatest mountain range on Midlantia runs from the Great Northern Ice southeasterly through Avalon, under the Bay of Lûne, and continues south through the Plains of Gehenna and into uncharted lands. While humans and their genus sometimes live in the shadows or on the slopes of these mountains, the real population lives far beneath where no sunlight can reach. Uncounted trolls, orcs, goblins, and worse creatures live in the maze of tunnels and caverns below the mountains.







# Chapter 9: The Organization of LAIRE...

You and your friend Steve arrive at the campsite. You've been to LAIRE events before, but only as non-player characters. This is your first Event where you will be player characters. You check with Logistics to find out which cabin you've been assigned, while Steve unloads the car. You take your sleeping bags and other gear to the cabin and change into your costumes, but you're still out-of-game, so you also put on white headbands. You go to the weapons check-in area, where both of you have your armor evaluated and receive an Armor Card. You have a foam longsword approved, and receive a Weapon Card. Then you both go to Logistics, where you and Steve fill out new Character Cards, and receive Body Point and Armor Point tags; Chris gets Power Point tags as well. Now you're ready. You remove your white headbands, and Silva and Ortral go in search of adventure.

## LAIRE Rules and Procedures

### The LAIRE Constitution

#### ARTICLE I, NAME

Explorer Post #2510 shall be known as the Live Action Interactive Roleplaying Explorers, LAIRE.

#### ARTICLE II, PURPOSE

The purpose of this post shall be to further leadership abilities, team building skills and positive social skills through live action roleplaying in a good and lawful medieval fantasy setting. To involve both youths and adults in this endeavor and through it build character and provide a healthy recreational outlet for all members, while being a positive influence for the community.

#### ARTICLE III, MEMBERSHIP

##### Section 1

Members shall be duly paid members of the Boy Scouts of America®.

##### Section 2

Voting, or Active, membership shall be granted to those paid members that attend least 4 full Events per year. A full Event is an Event that the member has validly checked in and checked out for, including payment of event fees if applicable. Voting membership will also be granted to paid members that do not fulfill this requirement due to military service or temporary disability by a majority of E-board.

##### Section 3

Membership shall also be granted by virtue of acceptance of all Boy Scout rules, regulations and responsibilities.

#### ARTICLE IV, EXECUTIVE BOARD

##### Section 1

The body governing LAIRE shall be the Executive Board, hereafter referred to as E-board. It shall be responsible for managing all aspects of LAIRE including, but not limited to, scheduling and running events, finance, maintenance of records, safety, rules, conduct, storage of property, adjudication and disciplinary action.

##### Section 2

The make up of the E-board shall be as follows:

- Executive Director (votes to make and break ties)
- Head of Finance (1 vote)
- Head of Plot (1 vote)
- Head of Logistics (1 vote)
- Head of Public Relations (1 vote)
- 4 Player Representatives (each with 1 vote)

##### Section 3

Each department head has absolute authority within their department over the running of their department. Only the E-board may sanction or remove a department head.

##### Section 4

The E-board shall meet at least once a month. The location and time of the meeting are to be decided by the Executive Director. The

meeting must be generally held in a centrally located place and time that is acceptable to 2/3rds of the E-board. The location of the meeting will never require expenditure for admittance, cover or parking. E-board members will be informed at least one week prior by the Executive Director of time and location. Meetings shall not begin before 6pm or end after 11pm. The requirements may be temporarily waived by unanimous consent of all E-board members.

#### Section 5

General Duties of all E-board members:

1. Act as a Full Marshal on camp when needed. Any incoming E-board members that are not already Full Marshals must become so within 3 months. Failure to do so will result in an immediate vote for removal from the E-board.
2. Mediate disputes between players and defuse potential problems as they arise.
3. To act as Executive Liaison whenever required.
4. Attend at least 70% of all E-board meetings. Proxies do not count as attendance.
5. Attend a majority of all the organization's events.

#### Section 6

Qualifications for election or appointment to the E-board:

1. Be an active member in good standing (no current violations).
2. Been an active member of the organization for the last 24 months.
3. Has attended a majority of Events for the prior 12 months.
4. If a person was a past E-board member, they must have left of their own accord from their previous position in good standing, or at least 48 months must have past since leaving in poor standing.

#### Section 7

Individual E-Board Positions:

1. Executive Director
  - A. Additional Qualifications:
    - a) Been an active member in good standing of the organization for at least 36 months.
    - b) Previously held an E-Board position for at least 12 months.
  - B. Responsibilities:
    - a) Schedule all E-Board meetings per Section 4.
    - b) Attend and set agenda for all E-Board meetings.
    - c) Set annual goals and objectives to further the organization's purpose as outlined in Article II.
    - d) Oversee the organizations events. Taking action when needed to overcome obstacles created by oversights, absences and conflicts. If any necessary action is contrary to this constitution, established policy, or rule, then it may only take place by first polling all E-board members in attendance and receiving the consent of the majority. Such action shall automatically be deemed temporary for that event and will not set precedent or change policy. All normal channels and procedures must be followed before effecting any permanent change to the organizations rules, games rules, guidelines or constitution.
    - e) Answer the questions and concerns of the parent or guardian of any youth member.

- f) Schedule at least one general membership meeting a year. The meeting must be generally held in a centrally located place and time that is acceptable to 2/3rds of the E-board. The location of the meeting will never require expenditure for admittance, cover or parking. Members will be informed at least one month prior by the Executive Director of time and location.
  - g) Votes to make or break any tie votes occurring by E-Board.
  - h) May cancel, postpone or delay start of events due to inclement weather with the assent of at least one other E-Board member.
  - i) Act as a full member of all committees.
  - j) Nominate and manage a recording secretary.
- C. Term: 2 years beginning July 1<sup>st</sup>
2. Head of Plot
- A. Additional Qualifications:
- a) Played the game for a majority of Events in each of the prior 24 months as well as 8 of the last 12 Events.
  - b) Previously been a full plot marshal on the Plot Committee for at least 12 months ever and remained in good standing while holding that position.
  - c) Provide a 2 year overview to the E-board with a sense of the direction that the game will take.
- B. Responsibilities:
- a) Schedule and attend virtual or live Plot Committee meetings.
  - b) Appoint and supervise Plot Marshals and Plot Staff.
  - c) Oversee the purchase of Props, makeup and costumes.
  - d) Appoint and supervise a Prop Manager to oversee the storage and maintenance of Props, makeup and costumes.
  - e) Appoint and supervise a Treasure Manager to oversee the storage, design, development, inventory and security of items to be used as game treasure.
  - f) Provide an overall workable storyline for the game and various themes for each Event.
  - g) See to supervision of all NPC's at each Event.
  - h) Approve all exceptional abilities granted to PC's.
  - i) Grant special dispensations to PC's that would retroactively effect events. Any such action shall be done in a manner so as not to affect actual visual history beyond the previous Event without the agreement of the Executive Director or a majority of E-board present, excluding character deaths.
  - j) Maintain a written in-game history for reference purposes.
- C. Term: 2 years with a performance review after first 3 months and every year of term with a maximum of 2 consecutive terms.
3. Head of Finance
- A. Additional Qualifications:
- a) Attended a majority of Events in each of the prior 24 months.
- B. Responsibilities:
- a) Maintain an up-to-date membership information list for all members.
  - b) See to the collection and deposit of annual dues and Event fees.
  - c) Maintain a checking account for payment of the organization's operating costs, with both the Head of Finance and the Executive Director as authorized signatories.
  - d) Book sites for Events.
  - e) Provide a monthly report to E-board on the organization's finances.
  - f) Provide an end of year fiscal report detailing the income, expenditures, and liquid assets.
  - g) Act as Troop Leader, and as such the liaison to the BSA.
- C. No term limit (minimum of 1 year with notice given 3 months prior to leaving post)
4. Head of Logistics
- A. Additional Qualifications:
- a) Served on the Logistics staff for at least 12 months.
  - b) Must have an understanding of the current LAIRE database system.
  - c) Must be able to manage and oversee the Logistics staff so that all of the responsibilities of Logistics can be completed in a satisfactory manner.
  - d) Must have a reasonably secure Location to store all Logistics materials
  - e) Must have reliable transportation for the transport of Logistics' materials to and from all LAIRE Events.
- B. Responsibilities:
- a) Maintain database of all past and present member's character information for at least 5 years.
  - b) Organize all pre-registered members for Events.
  - c) Designate all sleeping assignments and all work assignments.
  - d) Train and supervise logistics staff and ensure coverage to allow both sign-in and check-out throughout Events within reason.
  - e) Post sleeping assignments Wednesday before the Event.
- C. No term limit (minimum of 1 year with notice given 3 months prior to leaving post)
5. Head of Public Relations
- A. Additional Qualifications:
- a) Served on the PR staff for at least 12 months.
  - b) Must be able to manage and oversee the PR staff so that all of the responsibilities of PR can be completed in a satisfactory manner.
  - c) Must have a reasonable secure location to store all PR materials
  - d) Must have reliable transportation for the transport of PR materials to and from all LAIRE Events.
- B. Responsibilities:
- a) Maintain, facilitate, and monitor all materials that are viewed by the public about LAIRE.



- b) To promote LAIRE at events and places that caters to our membership demographic.
  - c) To encourage the growth of the player base of LAIRE.
  - d) Maintain a LAIRE phone line to answer inquires of members and potential members.
  - e) To oversee the content and maintenance of the LAIRE website.
  - f) To oversee and manage recruitment and training of new members.
  - g) To ensure that the PR committee is available for contact and support of all new members for their first 12 months.
- C. No term limit (minimum of 1 year with notice given 3 months prior to leaving post)
6. Player Representatives
- A. Additional Qualifications
    - a) None.
  - B. Responsibilities:
    - a) Answer questions, respond to concerns and mediate disputes of the general membership.
    - b) Be available for the membership to contact outside of Events.
    - c) Attend 70% of the organization Events.
- C. Term: 2 years beginning January 1<sup>st</sup>

**ARTICLE V, CONDUCT OF E-BOARD AND E-BOARD MEETINGS**

**Section 1**

- 1. The Executive Director shall chair the E-Board meetings.
- 2. No official actions or decisions may take place without a quorum. A quorum is 5 of the 8 regularly voting members. Any action in the absence of a quorum by an E-board member or members beyond their posts responsibilities shall be temporary only.
- 3. Meetings may officially begin any time after the designated start time and a quorum is in attendance, however no official votes may be taken until after the first 15 minutes of the meeting have transpired unless all E-Board members are present.
- 4. Meeting timeline:
  - A. The Executive Director raises all issues of immediate importance.
  - B. Issues tabled from prior meeting.
  - C. Issues of individual E-Board members (order of presentation rotated each meeting)
  - D. Final comments and conclusion of meeting by Executive Director.
- 5. Any member may have an issue tabled until the next meeting to allow for further information to be gathered. Said issue may only be tabled once in this manner. Should an issue require immediate action, this tabling may be overruled but only by a unanimous vote of all other E-board members in attendance including the Executive Director. Issues may also be tabled by a simple majority vote.
- 6. While the E-board may vote on any issue it deems so necessary, the following issues will always require a recorded vote to enact.
  - A. Selection of new E-board members.

- B. Any changes to the game rules that would require an addition, deletion or change of the wording in the standard rule book. A 6 of 8 vote needed to enact any such change.
- C. Disciplinary action.
- D. Expenditures of \$100 or more outside of regular budgets.
- E. Determining if a departure from post is in good standing.
- F. Removal of an E-board member from his post.
- G. Overriding an E-board member's right to table an issue per Paragraph 5

**ARTICLE VI, SELECTION AND REPLACEMENT OF E-BOARD MEMBERS**

**Section 1**

Selection of E-Board Members

When any position on the E-Board other than Player Representative becomes vacant then the membership will be informed of the vacancy at the next Event. A two week period shall then be given for all interested, eligible candidates to submit their name to E-Board for consideration. Anytime thereafter the E-Board shall, by vote, select the replacement. In the event a Player Representative post is vacated prior to the regular completion of the post's 2 year term, the following method shall be used to fill the post.

If the vacancy occurs prior to July 1<sup>st</sup> of the first year of the term, the position shall be offered to the unelected candidates from the most recent year end election from the recipient of the highest vote total to the lowest until the post is filled.

If the vacancy occurs on or after July 1<sup>st</sup>, it shall remain vacant and be filled through the year end election. If the post would be up for reelection regularly there is no change in the election process. If the post would not be up for reelection until the following year, members will vote for an additional Player Representatives during the year end election. The recipients of the 2 highest vote totals will fill the regularly elected 2 year term while the next highest shall complete the term of the vacated post.

**Section 2**

Resignation

Any member wishing to leave their post prior to a properly completed term must submit a letter of resignation to the E-board. The E-board upon its next meeting after the resignation takes effect shall upon consideration of both circumstance and the orderliness of the transition, deem the resignation acceptable or unacceptable. An unacceptable resignation shall disqualify one from any future service on the E-Board.

**Section 3**

Removal from Post

Should an E-Board member by action or inaction fail to complete the duties required of their post, or act in a manner inappropriate for, or contrary to the Boy Scout code of ethics as mentioned in Article III section 3 they may be removed from their post.

For removal of an E-Board member from their post the following steps must occur in their given order;

- 1. An E-Board member calls for a vote of removal.
- 2. The E-Board member in question is notified of pending vote.

3. Reasons for removal are presented and discussed. Opportunity for the E-Board member to respond shall be given.
4. Vote is taken, if 6 of 8 regularly voting E-Board members agree said E-Board member is removed from their post.

The Executive Director may also remove any E-board member from their post at any time for any reason but such a removal must then be ratified at the next E-board meeting by a 6 of 8 vote.

## **ARTICLE VII, ELECTIONS**

### **Section 1**

Each December an election shall be held to choose two new Player Representatives, and answer any other questions placed before the membership for a general vote.

1. All eligible candidates for Player Representative must acquire 10 unique signatures from active members if they wish to be placed upon the ballot, and must submit their request in writing to a Player Rep by October 15<sup>th</sup>.
2. The Player reps shall prepare and collect all ballots and organize and oversee online voting via the LAIRE website.
3. All returned ballots shall be held by the Player Reps and not opened until the conclusion of the December Event. At the December event any member whose ballot has not yet been received may still vote by noon on Sunday of the Event. No further ballots shall be accepted, past noon. Once cast, a vote is final.
4. Any member who so desires shall be allowed to view the ballot counting.
5. Ballots shall then be opened, counted and results announced at closing ceremonies of the December Event.
6. In the event that there are fewer candidates available relative to the Player Representative positions begin voted on, the E-Board shall nominate and vote upon candidates until all positions are filled with a 6 of 8 Yea vote.

### **Article VIII, Changing Organizational Rules and Procedures**

Any changes to this constitution, or the rulebook, are governed by the following provisions. :

1. Changes may only be proposed by a member of E-Board.
2. Change proposal format shall be determined by the Executive Director.
3. Any change proposals must pass by at least a 70% Yea vote of the currently sitting E-Board to be enacted.
4. Proxy Votes may be given by E-Board members to others.

## **Disciplinary Actions**

Failure to adhere to the LAIRE rules, either the rules of the game or the rules of the organization, can result in disciplinary action. Depending on the intent and severity of the violation, members may receive disciplinary actions ranging from a warning to immediate permanent removal from the organization.

LAIRE will not permit or condone the following:

- The use of alcoholic beverages or illegal drugs at any Event or meeting. No one may arrive at an Event site under the influence of alcohol or drugs. The use of prescription medication should be reported to the staff at the beginning of an Event.

- The use of materials or ideas that could promote out-of-game violence.
- Out-of-game violence or harassment. This includes verbal or physical.
- Theft or vandalism of any property belonging to LAIRE, to a participant, or to an Event host's site.
- Open and gross lewdness, sexual harassment, or pornography.
- Actions that reflect a lack of respect for the safety or security of anyone or anything involved in a LAIRE Event.
- The out-of-game discrimination against anyone for their race, creed, color, gender, handicap, religious belief, appearance, ideology, or any condition which may be part of the player's background. Note that this is different from discriminating against a character's background; it is ok to dislike Half-Elves, but it's improper to be prejudiced against women.
- Any activity that is against the law.

## **Working for LAIRE**

The organization of LAIRE only continues to function through the hard work and dedication of those members that volunteer to help make it work. Ideally, all members should volunteer something of themselves to keep the game running smoothly. Some members volunteer their time by making props, others by becoming marshals, still others by joining E-Board or one of the committees that help run various aspects of the game. In whatever way seems best to you, volunteering for something will ensure that LAIRE continues to thrive for many years to come.

There are four main ways that members can volunteer to help to LAIRE. These ways, as well as how to get involved with them, are listed below.

### **Donations**

LAIRE is always in need of new props, weapons and of course; spell packets! One very good way to help out is to donate these items. However, the needs of the organization for these items varies so please be sure to check the Props Donation Page on the LAIRE website before attempting to donate anything, since unneeded donations will not be accepted. Please do not waste your time on things that are not needed.

Often, LAIRE will have materials available for purchase on site at Events for those players that would like to acquire weapon and spell packet making materials. Making weapons and spell packets for donation is a great way to get experience that will aid in making your own weapons look and feel even better. Remember that all such donations must first be passed by an Arms Marshal before they will be accepted.

All donations will be accepted at LAIRE Events. Please bring your donations to the props staff person responsible for accepting them 2 hours before the game lays on to lay on and 10am to noon on Sunday morning (or Monday of a 4-Day Event).

### **Marshals**

Marshals are those members of LAIRE who have volunteered to make sure that the rules and procedures of the organization are followed at Events by all members, and for rendering fair and equitable judgments on game situations. If you are going to perform

an action that you know is controversial, get a Marshal before you perform the action.

Marshals are volunteers. Their job is to keep the game fair and enjoyable. If a Marshal rules against you, remember that they are trying to be fair to someone else. Being a marshal is a serious undertaking and members that have become marshals should be treated with respect.

Only voting members that have attended more than 12 Events are eligible to become marshals. Eligible candidates for marshal status must then pass a written and practical test before they can become a marshal. These tests are given at regular intervals as listed below in the marshal status chart. If you are interested in becoming a marshal, just make sure you meet the requirements and then sign up for, and pass, the tests. Once you are a marshal, you will be required to serve as a marshal at least 6 duty shifts per year or you will lose all the marshal statuses you have. Members may have more than one marshal status; arms and magic for example. However, the player is only required to perform 6 shifts per year regardless of the number of marshal qualifications they have.

Marshals	Test Times
Rules	January and June
Alchemy	
Sorcery	
Module	April and October
Monster	
Rogue	
Arms	
Plot	None

Once a marshal makes a ruling, that ruling is final. Do not argue with a marshal or in any other way display poor sportsmanship. If you would like to contest a marshal's ruling, you may take your grievance to a Player Representative and only a Player Representative. Once you have brought your grievance to a Player Representative that Player Representative will then handle any inquiries and adjudications that are needed. Do not seek out another marshal in order to try to obtain another ruling; marshals cannot overrule each other. The only exception to this is that a member of E-Board can overrule another marshals ruling. In the event that there is a disagreement regarding a ruling amongst E-Board members, the Executive Director will always have the final say as to what ruling stands.

The Marshal status of a member is recorded on their Marshal Card. Every member may ask to see a members marshal card to verify their Marshal Status.

### Staff Positions

Many of the committees that help run LAIRE require that people volunteer more than just a 5 hour duty shift per Event to keep them running well. These staff members volunteer their time between Events as well as at Events themselves. There are also workers who do work primarily at an Event, but may receive Brownie Points for work done outside an Event. Their duties are whatever the head of their department requires within their committee's sphere of responsibility. Staff positions do not require marshal status, however many staff members often have a variety of different marshal qualifications as well.

Department	Staff Members
Logistics	Attend Cleanup, Tag Pull, and other assigned tasks. Perform their 5 hour duty shift at Logistics.
Finance	Perform their 5 hour duty shift at Finance.
Plot	Attend specific Plot meetings, write modules, marshal where needed, Monster Marshal, Module Marshal.
Treasure	Create, maintain, and manage all in-game LAIRE items. Perform their 5 hour duty shift at beginning of Events.
Props	Create, maintain, and manage all LAIRE props. Cleaning costumes between Events. Maintaining weapons between Events. Accepting new donations. Setting up and breaking down in-game areas. Maintaining the Props Lockers. Acquiring new props for LAIRE.
Public Relations	Conduct New Player Training. Act as new player aid. Assist with all between Event recruitment and marketing efforts.

Workers may be called upon to do any of the jobs or tasks a Staff Member does, but they are not required.

### E-Board

The Executive Committee of LAIRE affectionately known as E-Board is the governing body of the organization. These are the people that oversee and manage the day-to-day and long term activities that keep LAIRE going. For further information the qualifications, responsibilities and duties of each position are outlined in the Constitution of LAIRE in an earlier section of this chapter.





## Rewards for Working for LAIRE

While LAIRE greatly appreciates the efforts of all those that volunteer for the organization, LAIRE also rewards service with something a little more tangible than “Thanks”. Brownie Points, LAIRECash and Event Credits are all also awarded at various amounts for the different types of service members perform. The following chart outlines how the system works.

### Play Credits

Every time you go to a full Event weekend, you are required to have one Play Credit. The most common way to earn Play Credits is to NPC a full weekend. From time to time, LAIRE will have a special event usually lasting only a single day or night, for example, the Halloween Party. These events do not require a Play Credit to participate. **Any player that travels more than 200 miles to attend an Event does not require a Play Credit to participate.**

### LAIRECash

LAIRECash can be used only to offset the cost of LAIRE Events, up to half the cost of the Event. One LAIRECash equals one dollar.

### Brownie Points

A player can do many things with their Brownie Points. The table to the right outlines what the player may spend them on and how much they have to spend.

There may be times in-game that a player may be offered to buy items, scrolls and components for Brownie Points. This transaction is in-game and the player must find these people in-game.

Category	Brownie Point Cost
Build for a Character	1 Brownie Point per 0.1 Build Point up to a maximum of half the Awarded Build Points
In-Game Money	Brownie Point to copper pieces ratio will be posted at Events and on Laire.com
Resurrecting from a Black Marble	5 Brownie Points per Black Marble
Spell Defenses	1 Brownie Point per Power Point (3 Brownie Points per Power Point if lost magic) for each non 5 <sup>th</sup> Rank, non warlock enhanced Latent spell

Title of Job	Build Point Award	Brownie Point Award	LAIRECash Award	Event Credits Award
E-Board Member <sup>†,††</sup>	Max PC Build Points for 1 Character	500 per Year	240 per Year ½ Event Cost for 2 <sup>nd</sup> Character	2
Plot Director <sup>‡‡</sup>	4	250 per Event 500 per Year	20 per Event 240 per Year	1
Senior Plot Marshal <sup>**</sup>	4	250	20	1
Plot Marshal <sup>**</sup>	4	200	20	1
Plot Staff <sup>*</sup>	4	60	20	9
Event Director <sup>†</sup>	6	250	60	9
Assistant Event Director <sup>†</sup>	4	200	20	9
Monster Marshal Full Event <sup>†</sup>	5	80	25	9
Module Marshal, Including Setup and Cleanup <sup>†</sup>	-	25 per Party	5 per Party	-
Weekend Author	4	250 per Weekend When Used	20	1
Module Author				
Packet (1-3 Encounters)	-	20	2	0
Standard (6-8 Encounters)	-	40	10	0.5
Mega (12 Encounters)	-	60	20	1
NPC Full Weekend <sup>†</sup>	4	60	20	9
Marshal <sup>*,†</sup>	-	10 per Hour	1 per Hour	-
General Staff Member	-	5 per Hour	Half Event Cost for 1 Character	-
Logistics <sup>*</sup>	-	5 per Hour	1 per Hour	-
Props Transportation	-	20 per Trip <sup>‡</sup>	3 per 20 Miles	-
Work Not Covered Above	-	~5 per Hour	-	-

\* This is only awarded for work done above the required 5 hour work duty shift.

† Only one of these categories applies each Event.

‡ Final determination dependant on the Plot Director

\*\* In addition, if the Plot Member leaves in good standing they are excused from doing a work assignment for 1 Event for every 3 Events they performed their duties.

†† In addition, if the E-board Member leaves in good standing they are excused from doing a work assignment for 1 Event for every 6 Events they performed their duties. They also receive 1 free cost Event for every 2 months they served.

‡‡ The Plot Director, if they leave in good standing, is excused from doing a work assignment for 1 Event for every 3 Events they performed their duties and 1 free cost Event for every 2 months they served.

## Other Rules and Regulations

### Work Duty

Every player is required to perform a 5 hour work duty for the game every Event. Most players fulfill this requirement by NPCing for 5 hours. Some players satisfy this requirement in other ways such as working for Logistics, Treasure, or marshalling. These alternative tasks require special training and permission from their respective committee heads. All Plot Marshalls and E-board members are not required to perform this extra duty. **Any player that travels more than 350 miles to attend an event is not required to NPC or perform any other type of 5 hour duty shift.**

### Off Site and Out-of-Game Sleeping

All players should strive to stay in-game as much as possible. This includes sleeping in-game. While there is a strong temptation to sleep out-of-game to protect one's character, do not do so. If you are caught sleeping out-of-game in violation of the rules, the appropriate disciplinary action will be taken.

In order to sleep out-of-game, you must first get approval from an E-board member or Plot Marshal. Then you must fill out the Sleeping Out-of-Game form found at Logistics and get it signed by a Plot Marshal. The top half of the form is placed at Logistics with your Character Card and the bottom half of the form has to be placed at the location you are sleeping if your character is sleeping somewhere on camp. If someone finds your card, in other words finds you, you may get woken up and told you are found. You can get up and go and play your character. If you choose not to, you abdicate control of the encounter to the discretion of the Plot Marshal such as being killed, captured or left alone.

You may choose to sleep outside of the area represented by the camp. For example, your character goes to Greenstone, the Ducal Castle, Mistwood, or the Darkwood. In this case, you do not have to put a sign where you are sleeping. However, there is still a chance you may be woken up should some event occur where your character is sleeping. You will again have the option of playing your character or accept whatever happens to you if you do not. For example, a player has been given permission to sleep out-of-game. They fill out the form and indicate they are sleeping in Crossroads. That night, Crossroads is attacked. A Plot Marshal may come to you and tell you what is happening and give you the option of playing your character. If you choose not to, then be prepared to go along with the consequence of your choice.

Similarly, if you are sleeping somewhere off camp, you need to fill out the form and indicate where your character is sleeping. Players who sleep off camp cannot affect anything in-game while they are gone.

If you are leaving early or are not going to play that character again for the rest of the Event, you need not fill out one of these forms.

### Parking

At almost every camp there will be designated parking areas and a Parking Marshal who will direct parking. Please obey the parking rules. Typically, parking spaces closest to camp's entrance are reserved for e-board, plot, and emergency services. Failure to do so will result in the appropriate disciplinary action. No vehicles will be allowed on the camp after game has laid-on without permission from an E-board member.

### Leaving Early

If you need to leave the game at anytime before Sunday after final checkout, you need to inform an E-board member as soon as possible when you arrive at the camp. Failure to do so will result in the appropriate disciplinary action. Logistics closes 2 hours before game is called. If you do not check out before that time, you will not be able to until final check out.

### Cleaning Up and Checking Out

The game will be called usually 2 hours before sunset on Sunday. This time will be posted on the web site and in the OCFS (Opening Ceremonies Fact Sheet) at the Events.

It is the responsibility, duty, and obligation of every member at the Event to help clean up the camp. Besides your personal sleeping site area, you will be assigned a camp clean up area. Please be diligent in your duty. Our goal is to leave the camp cleaner than how we found it. It is your responsibility to ask for a clean up assignment if one is not given to you. Also, no one will leave and Logistics will not open, until the camp is cleaned. If you complete your assignment and see that more work needs to be done, then please ask what else you can do to help. The more help we get, the faster we can go home.

### Lost and Found

Lost and found will be located somewhere on camp at a location to be designated in the OCFS (Opening Ceremonies Fact Sheet). Lost and found may be stored between Events so check there before leaving camp. **LAIRE is not responsible for personal goods left on camp.**

### Camp Safety

#### *Bear Safety*

At almost every camp we go to, there will be a chance a bear may come for a visit. Below are some bear safety rules you should follow.

- NEVER approach a bear, especially a bear cub. A protective mother is usually nearby and may attack if she thinks her cub is in danger.
- Keep your campsite clean and never leave around food, garbage, coolers, cooking equipment or utensils. Avoid smelly cosmetics, perfumes, hair sprays, soaps, candy, beef jerky, toothpaste and anything else that has a smell that may attract an animal. Also, there are raccoons in the area that will gladly raid anything edible in your tent or area. Therefore, please keep anything that should not be in your tent area in one of the buildings on the camp or any specially designated food containers.
- Do not go to the bathroom in the woods by your tent.
- When a bear has been sighted and a warning given, travel in a group and make loud noises. Whistle, talk, sing, or carry a noise maker (e.g. whistles). Most bears will leave if they are aware of your presence. Stay in the open as much as possible.
- Make a wide detour or leave the area if you see a bear at a distance. If you cannot detour or retreat, wait until the bear

moves from your path. Always leave the animal an escape route.

- Do not run. Most bears can run as fast as a racehorse. A scream or sudden movement can trigger an attack.
- Do not throw anything at a bear; it may provoke an attack.
- Watch the bear for aggressive behavior: snapping its jaws together, making a “whoofing” sound, or keeping its head down with ears laid back. Consider any bear that moves toward you aggressive. If the bear does not seem to be displaying aggressive behavior, talk softly in monotones and slowly back up. If a bear rears on its hind legs and waves its nose in the air, it is trying to identify you. Keep still and speak in low tones.
- Keep calm. Assess the situation. There is no guaranteed life-saving method to cope with an aggressive bear, but calm behavior has proven the most successful. Sometimes bears will bluff their way out of a threatening situation by charging and veering away at the last second. Back away quietly; never run!

### ***Fire Safety***

Open flames are often used to create ambiance and period lighting. But fires can be dangerous. Care and caution should be taken when using fire at an Event.

Depending on season, rainfall, and the rules of the camp, campfires and open flame may be restricted. Check the web site and OCSF for the fire rules for that Event.

- NEVER leave fires unattended. Always put out candles and lanterns and make sure campfires are completely extinguished before leaving them. This includes the inn. If you are the last person out of the inn, make sure the candles are out and the fire place is put out.
- Do not build a campfire anywhere except in a fire ring. Most camps have fire rings already set up. Use them. Make sure you have a bucket of water or sand near the campfire to put out any stray fires that may start.
- Do not pitch a tent next to a fire, fire pit, or camp fire ring.
- Do not use open flames, such as candles or lanterns, inside of a tent.

Remember, only you can prevent forest fires.

### ***General Camp Safety***

The camps we use are not our property. LAIRE rents the use of these camps, usually from the Boy or Girl Scouts of America. We are guests. Do not chop down trees, do not break building, do not break furniture, and do not take anything. In other words, treat everything on the camp better than you would your own property.

However, accidents do happen. If you should break something, please inform an E-board member as quickly as you can.

Behavior that puts yourself, others or the camp at risk for injury or damage will not be tolerated. Such activities as climbing trees, walls, jumping out of windows, jumping through fires, climbing onto the roofs of buildings, throwing rocks, etc., is not acceptable behavior.

### ***Personal Care and Safety***

If you have a medical condition that requires you to test yourself regularly, use special medical equipment (knee brace, safety glasses, etc.), or take medication of any kind, you must inform the Executive Director and designated Health Marshal of your special medical needs when you arrive on camp. If you do not have or fail to use them you will be asked not to play until things are corrected.

If you are injured or get injured and are unable to play, you will not be allowed to. If you are unable to be struck in the knee, for example, due to a prior injury, you will not be allowed to participate in combat until you are well or have demonstrated the ability to play once more.



# Appendix A: Master List of Skills

Skill	Cost	Duration	Prerequisite Skill	Purch	Tagged	Skill List	Skill Type
Advanced Refining	5	Constant	Identify Component	Once	No	Alchemy	Arcane
Advanced Strength	10	Constant	Superior Strength	Once	No	Miscellaneous	Martial
Alchemical Focus	0	Constant	Alchemy Lore, Rank 3 of Any School	Once	No	Alchemy	Arcane
Alchemy Lore	2	Constant	Literacy, Herbal Lore	Once	No	Alchemy	Arcane
Armor Efficiency	4	Constant	Warrior Basic Career SL	Once	No	Master Warrior	Martial
Armor Smith	3	<i>Special</i>	None	Multi	Yes	Miscellaneous	Miscellaneous
Aspect of the Beast <sup>V,F</sup>	10	1 Hour	Shapeshift, Compel Mother's Children	Once	Yes	Druid	Faith
Assassin Proficiency	10	Constant	Master Assassin Skill	Multi	No	Assassin	Dexterity
Assassin Strike	4	Instant	1 Assassin Proficiency	Multi	Yes	Assassin	Dexterity
Assassinate	7	Instant	2 Assassin Proficiencies	Multi, <i>Special</i>	Yes	Assassin	Dexterity
Auras School	2/2/2/4 5/6	Constant	<i>Special</i>	Multi	No	Mage Basic Career	Arcane
Autopsy	2	Instant	Battle Surgery	Once	No	Master Miscellaneous	Arcane
Backstab	6/12	Constant	Waylay	Multi	No	Rogue Basic Career	Dexterity
Bark Skin <sup>V,F</sup>	4	30 Min	Pass Without a Trace	Multi	Yes	Druid	Faith
Battle Blessing <sup>V,F</sup>	4	30 Min	Paladin	Multi	Yes	Follower of the Light	Faith
Battle Surgery	4	<i>Special</i>	First Aid	Multi	Yes	Miscellaneous	Miscellaneous
Blind Fighting	5	Constant	1 Master Proficiency ~ or ~ 1 Assassin Proficiency	Once	No	Master Warrior, Assassin	Martial
Bonds School	1/2/2/4 3/6	Constant	<i>Special</i>	Multi	No	Mage Basic Career	Arcane
Channeling	10	Constant	2 Proficiencies, 30 Power Points, 1 <sup>st</sup> Rank School of Magic to be Channeled	Once	No	Master Warrior	Martial
Charms School	1/22/2/4 3/6	Constant	<i>Special</i>	Multi	No	Mage Basic Career	Arcane
Claws <sup>V,F</sup>	3	10 Min	Protector of the Mother	Multi	Yes	Druid	Faith
Cleric	3	Constant	Plot Approval, First Aid	Once	No	Follower of the Light	Faith
Climb	3	<i>Special</i>	None	Once	No	Master Miscellaneous	Dexterity
Cloak Undead <sup>V,F</sup>	5	6 Hours	Dark Cleric	Multi	Yes	Servant of Darkness	Faith
Coma	7	Constant	None	Once	No	Master Miscellaneous	Martial
Compel Greater Undead <sup>V,F</sup>	6	30 Min	Control Lesser Undead	Multi	Yes	Servant of Darkness	Faith
Compel Mother's Children <sup>V,F</sup>	8	30 Min	Nature's Child	Multi	Yes	Druid	Faith
Concentration	6	Constant	Any 3 Warlock Skills	Once	No	Warlock	Arcane
Control Lesser Undead <sup>V,F</sup>	6	30 Min	Dark Cleric	Multi	Yes	Servant of Darkness	Faith
Control Undead Horde <sup>V,F</sup>	10	30 Min	Compel Greater Undead	Multi	Yes	Servant of Darkness	Faith
Cosmic Focus	0	Constant	Rank 1 Sorcery	Once	No	Sorcerer	Arcane
Courage	3	5 Min	None	Multi	Yes	Master Miscellaneous	Miscellaneous
Craftsman Skills	3	Constant	None	Multi	No	Miscellaneous	Miscellaneous
Create Golem I-IV	2/2/2/2	Constant	Two Rank 5 of Potions, Poisons, or Solutions, Embalming	Multi	No	Alchemy	Arcane
Create Scroll	5	Constant	Read Magic	Once	No	Sorcery	Arcane
Critical Attack	5/10	Instant	Any Weapon Skill	Multi	Yes	Warrior Basic Career	Martial
Critical Backstab	3	Instant	Rogue Basic Career SL, 2 Backstabs	Multi	Yes	Master Thief	Dexterity
Dark Blessing <sup>V,F</sup>	3	10 Min	2 Woundings	Multi	Yes	Servant of Darkness	Faith
Dark Cleric	3	Constant	Plot Approval	Once	No	Servant of Darkness	Faith
Dark Paladin	2	Constant	Plot Approval, Dark Cleric	Once	No	Servant of Darkness	Faith
Dark Sorcerer	3	Constant	Plot Approval, Rank 3 Sorcery	Once	No	Servant of Darkness	Faith
Darkwood Ranger	3	Constant	Tracking	Once	No	Master Miscellaneous	Miscellaneous
Death School	1/2/2/2/4 3/6	Constant	<i>Special</i>	Multi	No	Mage Basic Career	Arcane
Death Touch <sup>*,V,F</sup>	10	Instant	Venom Touch	Multi	Yes	Servant of Darkness	Faith
Demonology School	3/3/4/4/6 7/9	Constant	<i>Special</i>	Multi	No	Mage Basic Career	Arcane
Destroy Lesser Undead <sup>*,V,F</sup>	3	Instant	Paladin, Detect Undead	Multi	Yes	Follower of the Light	Faith

Skill	Cost	Duration	Prerequisite Skill	Purch	Tagged	Skill List	Skill Type
Destroy Undead <sup>*,V,F</sup>	7	Instant	Destroy Lesser Undead	Multi	Yes	Follower of the Light	Faith
Detect Lie	3	Instant	Cleric	Multi	Yes	Follower of the Light	Faith
Detect Undead <sup>V,F</sup>	3	Instant	Cleric	Multi	Yes	Follower of the Light	Faith
Disarm	4/8	5 Sec	Any Weapon Skill ~ or ~ Master Assassin	Multi	Yes	Warrior Basic Career, Assassin	Martial
Disarm Trap	2/6	Constant	None	Once	No	Rogue Basic Career	Dexterity
Dissection	5	Constant	Alchemy Lore ~ or ~ Sorcery Lore	Once	No	Alchemy, Sorcery	Arcane
Distraction	4	10 Sec	Trap Dodge	Multi	Yes	Master Thief	Dexterity
Divination	3	Constant	None	Once	No	Miscellaneous	Arcane
Dodge	10	Instant	Rogue Skill List, 4 Unique Dexterity Skills	Multi	Yes	Assassin, Master Thief	Dexterity
Double Cast	5	Instant	Any 3 Warlock Skills	Multi	Yes	Warlock	Arcane
Double Power	5	Instant	Any 3 Warlock Skills	Multi	Yes	Warlock	Arcane
Druid	2	Constant	Protector of the Mother, Requires Plot Approval	Once	No	Druid	Faith
Dwarven Resist	3	Instant	None	Multi	Yes	None	Racial
Echo	6	10 Min	Spell Singing Rank 3	Multi	Yes	Spell Singer	Arcane
Elemental Pool Points <sup>V,F</sup>	5	Constant	Druid	Multi	Yes	Druid	Faith
Elemental Attunement	4	Constant	2 Elemental Pools	<i>Special</i>	No	Druid	Faith
Elemental Quintessence <sup>V,F</sup>	10	1 Hour	Nature Magic Rank 3	Once	Yes	Druid	Faith
Elven Resist	3	Instant	None	Multi	Yes	None	Racial
Embalming	2	<i>Special</i>	Alchemy Lore, Dissection	Once	No	Alchemy	Arcane
Empower Evil <sup>V,F</sup>	5	Latent	Dark Paladin, Dark Blessing	Multi	Yes	Servant of Darkness	Faith
Enchantments School	1/2/2/2/4/3/6	Constant	<i>Special</i>	Multi	No	Mage Basic Career	Arcane
Escape	4	Instant	Dodge	Multi	Yes	Assassin, Master Thief	Dexterity
Evaluate Item	3	Constant	None	Once	No	Miscellaneous	Miscellaneous
Evisceration	6	<i>Special</i>	None	Once	No	None	Arcane
Extend Duration	5	Constant	Alchemy Lore, Any 4 <sup>th</sup> Rank Alchemy School	Once	No	Alchemy	Arcane
Extend Spell Song	3	<i>Special</i>	Spell Singing Rank 4	Once	No	Spell Singer	Arcane
Extension	3	5 Min	Channeling	Multi	Yes	Master Warrior	Martial
Feat Of Strength	3	Instant or 15 Sec	Warrior Basic Career SL, 2 Staminas	Multi	Yes	Master Warrior	Martial
First Aid	2	Constant	None	Once	No	Miscellaneous	Miscellaneous
Florentine	3/9	Constant	Any One-Hand Weapon Skill	Once	No	Warrior Basic Career, Rogue Basic Career	Martial
Forest Meld <sup>V,F</sup>	6	<i>Special</i>	Pass Without a Trace	Multi	Yes	Druid	Faith
Greater Magic Weapon <sup>V,F</sup>	5	30 Min	Paladin ~ or ~ Dark Paladin	Multi	Yes	Follower of the Light, Servant of Darkness	Faith
Gypsy Curse	3	<i>Special</i>	None	Once	No	None	Racial
Heal Life <sup>*,V,F</sup>	10	Instant	2 Heal Wounds	Multi	Yes	Follower of the Light	Faith
Heal Wounds <sup>*,V</sup>	5	Instant	Cleric	Multi	Yes	Follower of the Light	Faith
Healing School	2/2/2/2/4/5/6	Constant	<i>Special</i>	Multi	No	Mage Basic Career	Arcane
Herbal Lore	3	Constant	None	Once	No	Miscellaneous	Miscellaneous
Hibernate <sup>V,F</sup>	3	<i>Special</i>	Forest Meld	Once	No	Druid	Faith
Holy Blessing <sup>V,F</sup>	3	10 Min	2 Heal Wounds	Multi	Yes	Follower of the Light	Faith
Hypnosis	10	30 Min	Master Assassin Skill	Multi	Yes	Assassin	Dexterity
Ice School	2/2/2/2/4/5/6	Constant	<i>Special</i>	Multi	No	Mage Basic Career	Arcane
Identify Component	3	Constant	Dissection	Once	No	Alchemist, Sorcerer	Arcane
Immunity to <i>Charm</i>	5	Constant	Paladin ~ or ~ Dark Paladin	Multi	No	Follower of the Light, Servant of Darkness	Faith
Inner Catalyst	0	Constant	Rank 5 Potions	Once	No	Alchemy	Arcane
Instructor	3	Constant	None	Once	No	Miscellaneous	Miscellaneous
Interrogate	3	Instant	None	Multi	Yes	Master Miscellaneous	Miscellaneous
Iron Will	10	Instant	None	Multi	Yes	Master Miscellaneous	Miscellaneous
Jump	3	<i>Special</i>	None	Once	No	Master Miscellaneous	Dexterity
Killing Blow Magic	2	Constant	Mage Basic Career SL, 4 <sup>th</sup> Rank of Any School	Once	No	Warlock	Arcane
Lie	3	Instant	Dark Cleric	Multi	Yes	Servant of Darkness	Faith

Appendix A: Complete List of Skills

Skill	Cost	Duration	Prerequisite Skill	Purch	Tagged	Skill List	Skill Type
Literacy	4	Constant	None	Multi	No	Miscellaneous	Miscellaneous
Make Contact	3	Constant	Any One Rank 3 Alchemy School	Once	No	Alchemist, Assassin	Arcane
Make Gaseous	3	Constant	Any Two Rank 4 of an Alchemy School	Once	No	Alchemist	Arcane
Master Assassin	8	Constant	Rogue Skill List, 20 Build Points of Dexterity Skills	Once	No	Assassin	Dexterity
Master Florentine	4	Constant	Warrior Basic Career SL, Florentine, 1 Master Proficiency	Once	No	Master Warrior	Martial
Master Parry	4	Instant	Warrior Basic Career SL, 2 Proficiencies	Multi, <i>Special</i>	Yes	Master Warrior	Martial
Master Proficiency	13	Constant	Warrior Basic Career SL, 2 Non-Master Proficiencies	Multi	No	Master Warrior	Martial
Master Set Traps	5	Constant	Quick Disarm, Set Trap 4	Once	No	Master Thief	Dexterity
Master Waylay	5	Constant	Waylay, 20 Build Points in Dexterity Skills	Once	No	Master Thief	Dexterity
Medium	3	Constant	None	Once	No	Miscellaneous	Arcane
Missile Deflection	3	Instant	Rogue Skill List	Multi	Yes	Assassin, Master Thief	Dexterity
Natural Claws	0	Constant	<i>Special</i>	Once	No	None	Racial
Nature Magic <sup>F</sup>	2/2/2/2	Constant	Elemental Pool, <i>Special</i>	Multi	No	Druid	Faith
Nature's Child <sup>V,F</sup>	5	10 Min	Pass without a Trace	Multi	Yes	Druid	Faith
Nature's Health <sup>V,F</sup>	4	Constant	Elemental Pool	Once	No	Druid	Faith
Nature's Purity <sup>V,F</sup>	5	10 Min	Elemental Pool	Multi	Yes	Druid	Faith
Necromancy School	2/2/2/2/4/5/6	Constant	<i>Special</i>	Multi	No	Mage Basic Career	Arcane
Overlay	6	Instant	Any 3 Warlock Skills, <i>Special</i>	Multi	Yes	Warlock	Arcane
Pain Touch <sup>*,V,F</sup>	6	5 Min	Dark Paladin, 2 Wounding	Multi	Yes	Servant of Darkness	Faith
Paladin	2	Constant	Plot Approval, Cleric	Once	No	Follower of the Light	Faith
Paralyze Touch	5	10 Min	Master Assassin Skill	Multi	Yes	Assassin	Dexterity
Pass Without a Trace	5	Constant	Protector of the Mother	Once	No	Druid	Faith
Perfect Aim	6	Instant	Any 3 Warlock Skills, <i>Special</i>	Multi	Yes	Warlock	Arcane
Pick Lock	2/6	Constant	None	Once	No	Rogue Basic Career	Dexterity
Pick Pockets	4	Instant	Speed Search	Multi	No	Master Thief	Dexterity
Poison Immunity	5	Constant	Rogue Skill List, 20 Build Points of Dexterity Skills ~ or ~ Resist Alchemy	Multi	No	Assassin, Master Thief, Alchemy	Dexterity
Poison Lore	2/6	Constant	Literacy, Herbal Lore	Once	No	Rogue Basic Career	Dexterity
Poisons I-V	2/2/3/4/5	Constant	Alchemy Lore ~ or ~ Poison Lore	Multi	No	Alchemist, Rogue Basic Career, Assassin	Arcane
Poison Spit	3	10 Min	None	Multi	Yes	None	Racial
Potions I-V	2/2/3/4/5	Constant	Alchemy Lore	Multi	No	Alchemist	Arcane
Power Points	1.5 PP per 1 Build / 1 PP per 1 Build		None	Multi	Yes	Mage Basic Career	Arcane
Professional Skills	1	Constant	None	Multi	No	Miscellaneous	Miscellaneous
Protector of the Mother	3	Constant	Plot Approval and Herbal Lore	Once	No	Druid	Faith
Pyrotechnics School	2/2/2/2/4/5/6	Constant	<i>Special</i>	Multi	No	Mage Basic Career	Arcane
Quick Disarm Trap	5	Instant	Rogue Basic Career SL, Disarm Trap, Trap Dodge	Multi	Yes	Master Thief	Dexterity
Quick Pick Locks	5	Instant	Rogue Basic Career SL, Pick Locks, Trap Dodge	Multi	Yes	Master Thief	Dexterity
Quick Study	3	Constant	None	Once	No	Miscellaneous	Miscellaneous
Rage	3	5 Min	None	Multi	Yes	None	Racial
Read Magic	1/6	Constant	Any Literacy	Once	No	Mage Basic Career	Arcane
Recover Power	2	Instant	Mage Basic Career SL, 4 <sup>th</sup> Rank of Any School	Multi	Yes	Warlock	Arcane
Redirect Spell	7	Instant	Channeling	Multi, <i>Special</i>	Yes	Master Warrior	Martial



Skill	Cost	Duration	Prerequisite Skill	Purch	Tagged	Skill List	Skill Type
Repel Undead <sup>V,F</sup>	5	<i>Special</i>	Turn Lesser Undead	Multi	Yes	Follower of the Light	Faith
Researcher	3	Constant	None	Once	No	Miscellaneous	Arcane
Resist Alchemy	3	Instant	Alchemy Lore, Any Two Rank 3 Alchemy School	Multi	Yes	Alchemist	Arcane
Resist Evil	5	Instant	Paladin	Multi	Yes	Follower of the Light	Faith
Resist Spell	3	Instant	None	Multi	Yes	None	Racial
Resist Truth	3	<i>Special</i>	Rogue Basic Career SL	Multi	Yes	Master Thief, Assassin	Dexterity
Set Trap	1/2/3/4 3/6	Constant	Disarm Trap	5	No	Rogue Basic Career	Dexterity
Set Trap 5	5	Constant	Set Trap 4	Once	No	Master Thief	Dexterity
Sever Soul <sup>*,V,F</sup>	4	Instant	Death Touch	Multi	Yes	Servant of Darkness	Faith
Shadow Magic School	2/2/2/2/4 5/6	Constant	<i>Special</i>	Multi	No	Mage Basic Career	Arcane
Shapeshift <sup>V,F</sup>	7	1 Hour	Nature's Child; Claws	Multi	Yes	Druid	Faith
Shatter Weapon	5	Instant	Warrior Basic Career SL, 1 Proficiency	Multi	Yes	Master Warrior	Martial
Shield Parry	3	Constant	Warrior Basic Career SL, 1 Proficiency, Any Shield Skill	Once	No	Master Warrior	Martial
Shield	5/15	Constant	None	Once	No	Warrior Basic Career	Martial
Slay	10	Instant	Warrior Basic Career SL, 2 Proficiencies	Multi, <i>Special</i>	Yes	Master Warrior	Martial
Solutions I-V	2/2/3/4/5	Constant	Alchemy Lore	Multi	No	Alchemy	Arcane
Sorcery Lore	2	Constant	Create Scroll, Rank 4 of Any School	Once	No	Sorcery	Arcane
Sorcery Rank 1	8	Constant	Sorcery Lore	Once	No	Sorcery	Arcane
Sorcery Rank 2	10	Constant	Sorcery Rank 1	Once	No	Sorcery	Arcane
Sorcery Rank 3	10	Constant	Sorcery Rank 2	Once	No	Sorcery	Arcane
Sorcery Rank 4	10	Constant	Sorcery Rank 3	Once	No	Sorcery	Arcane
Sorcery Rank 5	10	Constant	Sorcery Rank 4	Once	No	Sorcery	Arcane
Sorcery Rank 6	10	Constant	Sorcery Rank 5	Once	No	Sorcery	Arcane
Sorcery Rank 7	15	Constant	Sorcery Rank 6	Once	No	Sorcery	Arcane
Sorcery Rank 8	20	Constant	Sorcery Rank 7	Once	No	Sorcery	Arcane
Sorcery Rank 9	25	Constant	Sorcery Rank 8	Once	No	Sorcery	Arcane
Sorcery Rank 10	30	Constant	Sorcery Rank 9	Once	No	Sorcery	Arcane
Speed	6	Instant	Warrior Basic Career SL, 2 Proficiency	Multi	Yes	Master Warrior	Martial
Speed Cast	7	Instant	Any 3 Warlock Skills, <i>Special</i>	Multi	Yes	Warlock	Arcane
Speed Search	6	Constant	Rogue Basic Career SL, Evaluate Item	Once	No	Master Thief	Dexterity
Spell Binding	4	6 Hours	Mage Basic Career SL, 4 <sup>th</sup> Rank of Any School	Multi	Yes	Warlock	Arcane
Spell Holding	4	5 Min	Mage Basic Career SL, 4 <sup>th</sup> Rank of Any School	Multi	Yes	Warlock	Arcane
Spell Immunity	5	Constant	Mage Basic Career SL, 4 <sup>th</sup> Rank of Any School	Multi	No	Warlock	Arcane
Spell Singer	3	Constant	Literacy	Once	No	Spell Singer	Arcane
Spell Singing	4/4/4/4/4	Constant	Spell Singer, <i>Special</i>	Multi	No	Spell Singer	Arcane
Spell Singing Points	1.5 SSP for 1 BP	Constant	Spell Singer	Multi	Yes	Spell Singer	Arcane
Stamina	4	Constant	None	Multi	No	Miscellaneous	Martial
Stunning Blow	6/12	<i>Special</i>	Any 1 Proficiency	Multi	Yes	Warrior Basic Career	Martial
Superior Strength	15	Constant	None	Once	No	Miscellaneous	Martial
Swim	3	<i>Special</i>	None	Once	No	Master Miscellaneous	Dexterity
Thaumaturgy School	1/2/2/2/4 3/6	Constant	<i>Special</i>	Multi	No	Mage Basic Career	Arcane
Tight Rope Walker	4	Constant	Rogue Basic Career SL Climb	Once	No	Master Thief	Dexterity
Torture	3	Constant	None	Once	No	Miscellaneous	Miscellaneous
Total Power	10	Instant	Any 3 Warlock Skills, <i>Special</i>	Multi	Yes	Warlock	Arcane
Tracking	6	Constant	None	Once	No	Master Miscellaneous	Miscellaneous
Trap Dodge	4	Instant	Rogue Basic Career SL, Set Trap Rank 3	Multi	Yes	Master Thief	Dexterity

Appendix A: Complete List of Skills

Skill	Cost	Duration	Prerequisite Skill	Purch	Tagged	Skill List	Skill Type
True Aim	6	Instant	Warrior Basic Career SL, 1 Proficiency with a Ranged Weapon ~ or ~ 1 Assassin Proficiency	Multi	Yes	Master Warrior, Assassin	Martial
Turn Lesser Undead <sup>V,F</sup>	5	30 Min	Detect Undead	Multi	Yes	Follower of the Light	Faith
Turn Undead Horde <sup>V,F</sup>	8	30 Min	Repel Undead	Multi	Yes	Follower of the Light	Faith
Unlife	8	<i>Special</i>	Dark Paladin, Cloak Undead	Once	No	Servant of Darkness	Faith
Venom Touch <sup>*,V,F</sup>	8	5 Min	Pain Touch, Dark Paladin	Multi	Yes	Servant of Darkness	Faith
Waylay	5/15	5 Min	Small Weapon	Once	No	Rogue Basic Career	Dexterity
Weapon Accuracy	3	Instant	Warrior Basic Career SL, 1 Proficiency ~ or ~ 1 Assassin Proficiency	Multi	Yes	Master Warrior, Assassin	Martial
Weapon Barrier	6	1 Min	Weapons Master, 4 Proficiencies	Multi	Yes	Master Warrior	Martial
Weapon Proficiency	10/15	Constant	Any Weapon Skill	Multi	No	Warrior Basic Career	Martial
Weapon Skills:							
Small Weapon	0/0	Constant	None	Once	No	Warrior Basic Career, Rogue Basic Career, Mage Basic Career	Martial
One-Handed Edged	2/6	Constant	None	Once	No	Warrior Basic Career, Rogue Basic Career	Martial
One-Handed Blunt	2/6	Constant	None	Once	No	Warrior Basic Career	Martial
Bastard Sword	4/12	Constant	None	Once	No	Warrior Basic Career	Martial
Bastard Blunt	4/12	Constant	None	Once	No	Warrior Basic Career	Martial
Two-Handed Edged	4/10	Constant	None	Once	No	Warrior Basic Career	Martial
Two-Handed Blunt	4/10	Constant	None	Once	No	Warrior Basic Career	Martial
Quarterstaff	2/6	Constant	None	Once	No	Warrior Basic Career, Mage Basic Career	Martial
Polearm	5/12	Constant	None	Once	No	Warrior Basic Career	Martial
Spear	3/8	Constant	None	Once	No	Warrior Basic Career	Martial
Thrown Weapon	2/6	Constant	None	Once	No	Warrior Basic Career, Rogue Basic Career	Martial
Bow	3/9	Constant	None	Once	No	Warrior Basic Career, Rogue Basic Career	Martial
Crossbow	4/12	Constant	None	Once	No	Warrior Basic Career, Rogue Basic Career	Martial
Weapon Smith	4/6/8/10	Constant	None	Multi	No	Miscellaneous	Miscellaneous
Weapons Master	10	Constant	Warrior Basic Career SL, 50 Build Points of Martial Skills	Once	No	Master Warrior	Martial
White Sorcerer	3	Constant	Plot Approval, Rank 3 Sorcery	Once	No	Follower of the Light	Faith
Wounding <sup>*,V</sup>	5	Instant	Dark Cleric	Multi	Yes	Servant of Darkness	Faith

# Appendix B: Master List of Spells

This section summarizes the spells in the game. The column that describes the effects of the spell is abbreviated summary of the spell's description and not complete. The player should not rely on these descriptions and should refer to the complete spell description in Chapter 3.

## Auras

I Weave a *Protective and Warding* Aura of...

Rank	PP	Verbal	Effect	Duration
1	1	...Armor	3 Armor Points	Until Used Up
1	2	...Stamina	3 Body Points	Until Used Up
1	3	...Defense	Damaging spells reduced by half; Kill or Life spell does half the character's Body Point total	Latent
2	4	...Vigilance	Stops a Waylay 3 or less; does half the current Body Points for Slay or Assassinate	Latent
2	5	...Negation	Stops one low magic, Nature Magic, or Spell Song spell	Latent
2	6	...Reflection	Reflects one low magic spell back at the caster	Latent
3	7	...Fortitude	Grants a Threshold of 4	Latent, 5 Minutes
3	8	...Absorption	Stops one low magic spell and caster gains the spell's PP; stops one Nature Magic or Spell Song spell	Latent
3	8	...Invulnerability	Stops one physical attack	Latent
3	8	...Purity	Stops one external alchemical attack	Latent
4	12	...Resistance to Shield You	Stops any one magical or physical attack	Latent
5	16/1	...Dragon Skin to Harden Your Hide	Character gains 25 Body Points and Damage Resistance: Silver	Latent, 10 Minutes
5	24/2	...Elder Resistance to Shield You from Harm	Stop any one attack or effect regardless of the nature of the attack	Latent

## Bonds

I Create a Magical Seal that Will Cause...

Rank	PP	Verbal	Effect	Duration
1	1	...Attachment	Attaches one object to another, breaks with 10 lbs of force	10 Minutes
1	2	...Pin	Pins the right foot of target to ground, +3 Strength Bonus to break	30 Seconds
2	5	...Bind	Pins the targets arms to the side, legs together, feet to ground, +3 Strength Bonus to break arms or legs	1 Minute
2	5	...Lock	Attaches any one object to another, +3 Strength Bonus to break	1 Hour
3	6	...Free Action	Either removes any one Bonds spell or is a latent defense against any one Bonds spell	Latent or Instant
3	7	...Paralysis	Immobilizes the character	5 Minutes
3	9	...Imprisonment	Immobilizes the character and the character cannot be harmed or moved	5 Minutes
4	9	...a Wall of Paralysis	10 foot by 10 foot wall that paralyzes anyone who touches or crosses wall	While Concentrating
5	20/1	...this Portal and Dwelling to be Impenetrable	See spell's description	12 Hours

## Charms

I Command You to Obey and Charm You to...

Rank	PP	Verbal	Effect	Duration
1	1	...Fumble	Drops whatever is in specified hand	Instant
1	2	...Speak the Truth	Character must answer the next question truthfully	Special
2	4	...Be Dazzled	Character is Torso Stunned for 5 seconds	5 Seconds
2	5	...Resist Suggestion	Stops one Charm school spell, no visible effect	Latent
2	6	...Be Silent and Mute	Character cannot speak for duration	1 Minutes
3	6	...Fall Asleep	Character falls asleep	5 Minutes
3	8	...Be Enslaved	Character must obey commands of caster for duration; character acts without emotions or self determination	5 Minutes
4	12	...Be Dominated and Controlled	Character must obey commands of caster for duration	1 Hour
5	30/2	...Be My Soul Slave to Obey My Every Command as I Enslave your Mind and Body and Dominate your Soul Forever	Character must obey command of caster for duration, undetectable, last through resurrection	Event

**Death**I Call Upon Darkness *and Terror* to...

Rank	PP	Verbal	Effect	Duration
1	1	...Feign Death	Makes the character appear dead	10 Minutes
1	2	...Cause Harm	6 points of magical direct body damage	Instant
2	4	...Weaken	Causes character to have a -2 Damage Bonus to all physical attacks	1 Minutes
2	4	...Maim	12 points of magical direct body damage	Instant
2	5	...Take Your Sight	Causes the character to be blind until cured	1 Minute
2	6	...Cause Agony	Causes the character intense pain, the character is unable to do anything for the duration	5 Seconds
3	6	...Drain Life	Causes 12 points of magical direct body damage and heals the caster up to 12 Body Points	Instant
3	6	...Cripple	18 points of magical direct body damage	Instant
3	7	...Enfeeble your Mind	Causes the character to lose all intelligence and renders them unable to take most actions	5 Minutes
3	8	...Incapacitate	24 points of magical direct body damage	Instant
4	9	...Cast a Wall of Enfeeblement	10 foot by 10 foot wall that enfeebles anyone who touches or crosses wall	While Concentrating
4	10	...Create a Spectral Weapon	Causes the weapon to swing for direct body	Latent, 5 Minutes
4	12	...Kill You and Wreak Havoc Upon Your Soul	Brings the character to the Brink of Death	Instant
5	18/1	...Kill Any Who Dare to Cross this Wall of Ash Before Me	10 foot by 10 foot wall that kills anyone who touches or crosses wall	While Concentrating
5	20/1	...Kill You and Hold Your Soul in Agonizing Torment Until You Die	Brings the character to the Brink of Death and reduces their Death Count by half	Instant, Special

**Demonology**From the *Unending* and <Aspect> Pits of Hell I... (*Fiery, Icy, Undying*)

Rank	PP	Verbal	Effect	Duration
1	0/1	...Detect Demon	Will reveal if a character or item is demonic	Instant
1	3	...Summon an Imp	Summons an Imp when cast on a player at the end of their Death Count.	1 Hour, <i>Special</i>
2	5	...Scourge Your Hands	Deals 8 points of <Aspect> damage and must drop everything in both hands.	Instant
2	5	...Summon a Demonling	Summons a Demonling when cast on a player at the end of their Death Count.	1 Hour, <i>Special</i>
2	6	...Command Lesser Undead	Controls all Imps, Demonlings, and Hellhounds in sound of voice.	30 Minutes
2	6	...Shield my Body from Possession	Latent defense that stops the character from being possessed.	Latent, <i>Special</i>
3	7	...Summon a Hell Hound	Summons a Hellhound when cast on a player at the end of their Death Count.	1 Hour, <i>Special</i>
3	7	...Cast a Circle of Binding	Creates a circle that demons cannot pass using a 10 to 20 foot piece of garland.	End of Tag Cycle
3	8	...Summon a Lesser Demon	Summons a Lesser Demon when cast on a player at the end of their Death Count.	1 Hour, <i>Special</i>
3	9	...Burn Your Soul	Deals 24 points of <Aspect> damage and a 5 sec Torso Stun	Instant
4	10	...Hasten Your Demise	Cuts the character's Death Count and current count in half.	Instant, <i>Special</i>
4	12	...Dominate this Demon	Controls the target Demon for duration. May attack caster unless ordered not to.	1 Hour
4	15	...Summon Dark Energies to Power Me	Gains 40 point demonic <Aspect> energy pool. Fades in 1 hour. Can throw and channel at one to one.	<i>Special</i>
4	20	...Summon a Demon to Obey Me	Summons a Demon when cast on a player at the end of their Death Count.	1 Hour, <i>Special</i>
4	20	...Summon Total Demonic Power to Infuse me with Magic	Character gains 30 Power Points that can only be used to cast Demonology spells	End of Tag Cycle



**Enchantments** With Pure Magic I Cast an *Unyielding...*

Rank	PP	Verbal	Effect	Duration
1	1	...Shock	4 points of magical damage due to lightning	Instant
1	2	...Giant Strength	Grants a temporary +3 Strength Bonus, Non-Combinable	Latent
2	3	...Lightning Shield	Stops one Enchantment spell or damage from one lightning attack	Latent
2	4	...Lightning Bolt	16 points of magical damage due to lightning	Instant
2	4	...Magic Weapon	Causes the weapon to swing for magic for one attack	Latent
2	4	...Mighty Shatter	Destroys one non-contiguous object One-Handed Edge size or smaller	Instant
3	6	...Wall of Force	10 foot by 10 foot wall that is impenetrable	While Concentrating
3	6	...Powerful Blast	Destroys one non-contiguous object door size or smaller	Instant
3	6	...Electrocution	24 points of magical damage due to lightning	Instant
3	9	...Magic Sanctuary	Creates a skin tight impenetrable barrier around the caster	While Concentrating
4	10	...Powerful and Masterful Strength	Grants the character a +2 Strength Bonus, non-combinable	Latent, 5 Minutes
4	12	...Circle of Force to Protect Me	10 foot high, 10 foot radius impenetrable wall around caster	While Concentrating
5	21/1	...Haven About Me to Protect Me on My Way	10 foot high, 10 foot radius impenetrable closed cylinder centered on the caster	While Concentrating
5	20/1	...Electrical Storm to Incinerate All Before Me	Ten bolts of lightning doing 16 points of magical damage due to lightning	Instant, Special

**Healing** I Draw Upon the Earth to *Aid Me and...*

Rank	PP	Verbal	Effect	Duration
1	0/1	...Detect Life	Determines if character is alive, dead, in their Death Count, and how many Body Points they are down	Instant
1	Var	...Heal this Person	Heals character 3 Body Points for every Power Point used to cast spell	Instant
2	2	...Purify Blood	Removes most poisons and alchemical items affecting the character	Instant
2	4	...Assess Your Ailment	Determines everything Detect Life does plus if the character is poisoned, diseased, if they are waylaid, infected by a another life form	Instant
2	4	...Heal this Body	Cures most diseases affecting the character, one at a time	Instant
2	4	...Heal this Mind	Cures insanity, amnesia, and possession at Plot Marshal's discretion, one at a time	Instant
3	5	...Heal this Limb	Heals and restores any broken or lost limbs	Instant
3	6	...Heal this Mortal Wound	Heals a character who is Mortally Wounded to 1 Body Point	Instant
3	6	...Return your Spirit	Resurrects a character to full Body Points after they are dead, uses the Death System	Permanent
3	8	...Bring this Ghoul to Life	Returns a character that has been turned into a Ghoul at 0 Body Points	Instant
4	12	...Heal this Life and Reclaim this Spirit	Returns the character back to life from the Brink of Death at 1 Body Point	Instant
4	14	...Heal this Person and Restore them to Full Health	Heals the character's Body Points to their current total, purifies their blood, heals their mind, body, and all limbs	Instant
4	20	...Purge this Death Slave of Their Necromantic Taint and Restore Their Will	Returns a character that has been turned into a Death Slave at the Brink of Death	Instant

**Ice** By the North Mist I Form a *Freezing Cold...*

Rank	PP	Verbal	Effect	Duration
1	2	...Ice Dart	8 points of magic damage due to ice	Instant
1	2	...Frost Brand	Causes the weapon to swing for ice damage for one swing	Latent
1	3	...Ice Cast	Immobilizes one arm, leg, wing, tail, or tentacle	30 Seconds
2	3	...Ice Shield	Stops one Ice School spell or damage from one ice attack	Latent
2	4	...Ice Bolt	16 points of magic damage due to ice	Instant
2	5	...Preservation	Stops the character's Death Count while caster maintains contact	Special
3	6	...Spear of Ice	24 points of magic damage due to ice	Instant
3	6	...Wall of Frost	10 foot by 10 foot wall that causes 14 points of magical ice damage to anyone who touches or crosses wall	While Concentrating
4	10	...Artic Wind to Stun You	Character is Torso Stunned for 10 seconds	10 Seconds
4	10	...Icy Imprisonment	Stops the character's Death Count for the duration	1 Hour
5	20/1	...Artic Maelstrom to Rend my Enemies with the Bone Chilling Power of Ice	Ten bolts of ice doing 16 points of magical damage due to ice	Instant, Special

**Necromancy**I Control Chaos *and Evil from my Heart* to...

Rank	PP	Verbal	Effect	Duration
1	1	...Feign Life	Makes an undead character look alive	10 Minutes
1	2	...Cause Disease	Causes character to immediately lose 1 Body Point and swing 1 less point of damage and every 10 minutes after, character dies after 6 hours	6 Hours
1	2	...Create a Zombie	Turns a dead character into a Zombie	<i>Special</i>
1	3	...Command Undead	Give one simple command to all lesser undead in sound of voice	1 Command
2	3	...Create a Skeleton	Turns a dead character into a Skeleton	<i>Special</i>
2	5	...Rot Flesh	15 points of magical rot damage	Instant
2	6	...Wither Limb	Causes an arm or leg to become useless until healed	Instant
3	8	...Create a Ghoul	Turns a character at 0 Body Points into a Ghoul	<i>Special</i>
3	9	...Dominate Undead	Dominates any undead to obey caster	1 Hour
3	9	...Shield from Sunlight	Protects an undead character from sunlight	Until Sundown
3	9	...Cripple You with the Plague	Character reduced to 1 Body Point, swings 1 point of damage, cannot use Advanced Career skills, and can only walk for duration. If killed by spell, will raise up as Greater Skeleton.	5 Minutes
4	10	...Decay Flesh and Bones	30 points of magical rot damage	Instant
4	12	...Create a Revenant	Turns a dead character into a Revenant	<i>Special</i>
4	20	...Create a Death Slave Who Will Obey my Each and Every Whim	Turns a character into a Death Slave	1 Hour
5	30/2	...Raise all the Dead Who Rest in this Graveyard to Serve my Each and Every Whim	Raise 100 undead. See spell description	Until Destroyed

**Pyrotechnics**I Summon Forth an Eldritch *and Fiery*...

Rank	PP	Verbal	Effect	Duration
1	0/1	...Light	Creates a light	<i>Special</i>
1	0/1	...Match	Light a piece of wood aflame	Until the Flame Burns Out
1	2	...Flare	8 points of magical damage due to fire	Instant
1	2	...Fire Brand	Causes the weapon to swing for fire damage for one swing	Latent
2	3	...Fire Shield	Stops one Pyrotechnics School spell or damage from one fire attack	Latent
2	4	...Fireball	16 points of magical damage due to fire	Instant
2	6	...Inferno	24 points of magical damage due to fire	Instant
3	6	...Wall of Flame	10 foot by 10 foot wall that causes 14 points of magical fire damage to anyone who touches or crosses wall	While Concentrating
3	8	...Dragon's Breath	32 points of magical damage due to fire	Instant
4	12	...Lava Burst to Burn My Enemies	48 points of magical damage due to fire	Instant
5	20/1	...Meteor Swarm to Destroy my Enemies with the Power of Fire	Ten balls of fire doing 16 points of magical damage due to fire	Instant, Special
5	30/2	...Volcano to Smite Down my Foes with the Raging Power of the Deep Fires of the Earth	Ten balls of fire doing 24 points of magical damage due to fire	Instant, Special

**Thaumaturgy**I Pierce the Veil of *Force and Energy* to...

Rank	PP	Verbal	Effect	Duration
1	0/1	...Detect Magic	Identifies if an object is magical	Instant
1	1	...See Magic	Cause all object in 5 feet to glow if they are magical	Instant
1	2	...Know Your Magic	Identifies all spell – Latent or active – upon the character	Instant
2	3	...Detect Curse	Identifies if a character is cursed	Instant
2	4	...Sever Magic	Destroys the magical link between caster and their spell	Instant
2	5	...Obscure	Stops one Thaumaturgy spell, there is no visible effect	Latent
2	6	...Dispel Magic	Dispels the effects of one spell upon the character	Instant
3	6	...Drain Magic Power	Character loses 10 Power Points, caster gains up to 10 Power Points	Instant
3	9	...Destroy Magic	Destroys all Latent low magic spell, stopped by sorcery	Instant
3	9	...Quiet Sorcery	Brings down sorcerous latent defensive magics for 5 minutes, stopped by low magic spell defenses	Instant
4	10	...Identify Magic	Identifies the magical properties of an object	Instant
4	10	...Identify your Curse	Identifies the curses affecting a character	Instant
5	21/1	... <i>Disrupt Your Magical Defenses and kill You Where you Stand</i>	Special	<i>Instant</i>

**Nature Magic**

By Nature's Will, I...

Rank	EPP	Verbal	Effect	Duration
1	2	...Create Food and Water	Produces food and water	Instant
1	3	...Repel this Being	Repels character back 10 feet	While Concentrating
2	4	...Entangle Your Limbs	Character's arms and legs bound for 3 seconds	3 Seconds
2	4	...Heal Your Disease	Cures most diseases	Instant
3	9	...Strike You Down with Thunder and Lightning	24 points of magical lightning damage and 5 second Torso Stun	Instant
3	9	...Grow Wall of Brambles	Creates a 10 foot by 10 foot wall of brambles	End of Current Tag Cycle or Until Destroyed
4	12	...Travel Through this Tree to Another Place	Allows character to travel out-of-game from one tree to another	<i>Special</i>
4	14	...Transmute Your Flesh to Stone Forever	Turns character to stone	End of Current Event
4	14	...Transmute You Back to Flesh Again	Turns a petrified character to flesh again	Instant

**Spell Songs**

Rank	SSP	Spells Name	Effect	Duration
1	0	Will'o'Wisp	Creates a light	<i>Special</i>
1	2	Feat of Heroes	Grants a temporary +3 Strength Bonus, Non-Combinable	Latent
1	Var	Heal	Heals character 2 Body Points for every Spell Singing Point used to cast spell	Instant
1	3	Confusion	Charms character to be confused and unable to take actions	While Sung
1	3	Inspire	Grants a +1 Damage Bonus	Latent, 10 Minutes
2	Var	Injure	Harms character 2 Body Points for every Spell Singing Point used to cast spell	Instant
2	3	Wake	Awakens a character who is asleep or Unconscious	Instant
2	3	Vocalize	Either protects character from being silenced or cures them	Latent or Instant
2	4	Repulse	Repels character back 10 feet	While Sung, Concentration
2	4	Resist Spell Song	Protects character from one spell song or sonic attack	Latent
3	5	Harmonize	Protects character from one spell song or sonic attack and character gains Spell Singing Points used to cast song	Latent
3	6	Silence	Character cannot speak for duration	While Sung
3	6	Sleep	Character falls asleep	While Sung
3	7	Freedom	Frees the character from any Bond School spell, Paralysis Touch, or Paste of Binding	Instant
4	10	Fear	Causes all character in Line of Sight and hearing to run away in fear	While Sung
4	14	Heroism	Grants every ally in Line of Sight and hearing +2 Damage Bonus and +9 healable Body Points	While Sung
4	14	Remove Curse	Removes all curses upon the character	Instant
4	15	Free Your Mind	Removes all mind affecting attacks from character	Instant
5	15	Repel true	Repels all characters 10 feet away from caster	While Sung
5	20	Haven	Ceases all hostile actions in sound of voice	While Sung
5	20	Destroy Being	Brings all characters to the Brink of Death	Instant
5	24	Legend Life	Brings a character at the Brink of Death to life	Instant



# Appendix C: Character Boons

During the course of playing the game, characters can gain Boons – special abilities or changes to existing skills specific to that character. Some Boons are gained as rewards for completing quests or some adventures. For example, becoming a Dragon Knight or Demon Knight gains the player a Boon. Every character can gain a boon once they reach Level 20.

Each character can have no more than four boons at any one time. This includes the Level 20 Boon.

## Gaining and Losing Boons

Boons are given out on a case by case bases. The Head of Plot is the final arbiter on who gets what Boon. These Boons can be taken away at any time and for any reason; they are not a right, but an extra

reward for good roleplay and, in the case of the Level 20 Boon, for surviving to Level 20.

## Requesting a Boon

The only Boon a player can request for their character is the Level 20 Boon. The player is encouraged to choose a boon from the list below. You may request a boon that does not appear on the list, but this may delay receipt of your boon. The Head of Plot will review your boon request and decide if it appropriate for your character and not overly game unbalancing. Minor changes to a boon from the list below will improve your chances of getting it approved.

Boons that may cause a Hold or require other characters to know how they work will probably not get approved.

A player created, unique Boon will generally not be approved for another character so long as the original character is still alive and played. Some of the Boons on the list below fall into this category.

Boon Name	Tagged	Used	Duration	Category
Master Alchemist	No	Special	Constant	Alchemist
Master Brewer	No	1x/Event	Constant	Alchemist
Improvised Assassin	No	-	Constant	Assassin
Master Channeler	No	-	Constant	Channeler
Spell Reclamation	No	-	Constant	Channeler
Elemental Life	Yes	1x/Event	Instant	Druid
Greater Tree Walk	No	-	Constant	Druid
Destroyer of Undead	No	1x/Tag Cycle	Constant	Follower of Light
Draconic Life	Yes	1x/Event	Instant	Follower of Light
Greater Holy Blessing	No	-	Constant	Follower of Light
Greater Resist Evil	No	Special	Latent	Follower of Light
Latent Holy Blessing	No	Special	Latent, 10 Min	Follower of Light
Resilient Healer	No	-	Instant	Follower of Light
Battle Hardened	No	-	Constant	General
Frightening Aura	Yes	1x/Event	10 Minutes	General
Frightening Visage	Yes	2x/Tag Cycle	10 Minutes	General
Hated Enemy	Yes	1x/Tag Cycle	Instant	General
Rallying Cry	Yes	1x/Tag Cycle	Instant	General
Total Loyalty	No	-	Constant	General
Favored Spell	Yes	Special	Special	Mage
Favorite School	No	-	Constant	Mage
Power Reclamation	No	-	Constant	Mage
Dark Blood - Half-Ogre	No	-	Constant	Racial
Dark Blood - Half-Orc	No	-	Constant	Racial
Dark Blood - Half-Troll	No	-	Constant	Racial
Surface Adaptation	No	-	Constant	Racial
Greater Dodge	Yes	1x/Tag Cycle	Instant	Rogue
Trap Master	No	-	Constant	Rogue
Master Sorcerer	No	-	Constant	Sorcerer
Ritual Expert	Yes	2x/Tag Cycle	Instant	Sorcerer
Song of Greater Awakening	Yes	3x/Event	Instant	Spell Singer
Greater Perfect Aim	Yes	1x/Tag Cycle	Instant	Warlock
Master Warlock	Yes	1x/Event	Instant	Warlock
Spell Immunity Reclamation	No	-	Constant	Warlock
Expert Warrior	No	-	Constant	Warrior
Improvised Fighter	No	-	Constant	Warrior
Natural Fighter	No	-	Constant	Warrior
Resilient Warrior	No	-	Constant	Warrior
Greater True Aim	Yes	1x/Tag Cycle	Instant	Warrior/Assassin

## Boon Descriptions

The headings in the Boon descriptions – Tagged, Duration, and Category – is similar to the skill description section. The Used heading indicates how often a character can use this boon.

### Battle Hardened

**Tagged:** No  
**Used:** n/a      **Duration:** Constant  
**Category:** General

This perk gives the character an additional 15 Body Points to their Body Point Stat.

### Dark Blood – Half-Ogre

**Tagged:** No  
**Used:** n/a      **Duration:** Constant  
**Category:** Racial

This perk gives the Half-Ogre character an addition +1 Strength Bonus, Non-combinable.

### Dark Blood – Half-Orc

**Tagged:** No  
**Used:** n/a      **Duration:** Constant  
**Category:** Racial

This perk makes the Strength Bonus of the Half-Orc character combinable.

### Dark Blood – Half Troll

**Tagged:** No  
**Used:** n/a      **Duration:** Constant  
**Category:** Racial

This perk gives the Half-Troll character an addition +1 Strength Bonus, Non-combinable.

### Destroyer of Undead

**Tagged:** No  
**Used:** 1x/Tag Cycle      **Duration:** Constant  
**Category:** Follower of the Light

The character with this boon gains an extra Destroy Undead skill and does not die after using this skill successfully.

### Draconic Life

**Tagged:** Yes  
**Used:** 1x/Event      **Duration:** Instant  
**Category:** Follower of the Light

This Boon allows the character to bring another character that is at the Brink of Death back to life at full health (acts as *Heal Full* spell) and without having to use the Death System. This boon requires the use of the character's focus and a verbal, which must be at least 5 syllables, not including the skill's name, and must contain some reasonably recognizable version of the name of the skill. This boon is delivered by touch and may be used only once per Event

### Elemental Life

**Tagged:** Yes  
**Used:** 1x/Event      **Duration:** Instant  
**Category:** Druid

This Boon allows the character to bring another character that is at the Brink of Death back to life at full health (acts as *Heal Full* spell) and without having to use the Death System. This boon requires the use of the character's focus and a verbal, which must be at least 5 syllables, not including the skill's name, and must contain some reasonably recognizable version of the name of the skill. This boon is delivered by touch and may be used only once per Event

### Expert Warrior

**Tagged:** No  
**Used:** n/a      **Duration:** Constant  
**Category:** Warrior

This perk allows the character to combine their Stun and Critical Attack skills into one blow doubling the damage normally called - not the duration or effect of the Stun. The character must have one purchase of each skill unused for that Tag Cycle to use this perk.

### Favored Spell

**Tagged:** Yes  
**Used:** *Special*      **Duration:** *Special*  
**Category:** Mage

This perk allows the character to cast a favorite spell without a verbal or Power Points a number of times per Tag Cycle. The player must choose a spell they already know and can cast without restriction. They must get the tag(s) from Logistics and have them signed by a marshal.

Rank of Spell	Number of Uses per Tag Cycle
Rank 1	3
Rank 2	2
Rank 3	2
Rank 4	1

If the player chooses the Heal Person spell, they can heal 9 Body Points.

### Favorite School

**Tagged:** No  
**Used:** n/a      **Duration:** Constant  
**Category:** Mage

This perk allows the caster to choose a school they wish to be specialized in. They will cast all spells from that school at 1 Power Point less (minimum of 1 PP) and an opposite school at 1 Power Point Higher. The spell has the same Power Point cost as normal if the spell is Absorbed. The pair of schools are:

School Pairs
Pyrotechnics – Ice Magic
Enchantments – Bond
Healing – Death
Auras – Thaumaturgy
Charms – <i>Special</i>
Necromancy – Demonology

**Frightening Aura**

**Tagged:** Yes  
**Used:** 1x/Event      **Duration:** 10 Minutes  
**Category:** General

This perk allows a character to cause Fear to everyone in the sound of their voice and Line of Sight to the character. The target player must hear the attack for it to work. This perk can be used once per Event.

**Frightening Visage**

**Tagged:** Yes  
**Used:** 2x/Tag Cycle      **Duration:** 10 Minutes  
**Category:** General

This perk allows a character to use a Fear attack on another character. The character must have an unobstructed Line of Sight and the target player must hear the attack. This perk can be used 2 times per Tag Cycle.

**Greater Dodge**

**Tagged:** Yes  
**Used:** 1x/Tag Cycle      **Duration:** Instant  
**Category:** Rogue

Greater Dodge works just like the Dodge skill, but it allows the character to move up to 10 feet away from an area effect attack only. The player may not move in defense of non-area effect attacks with this skill. The player must have a non-obstructed direction in which to move to and cannot be encumbered (i.e. carrying another character). The character may not cross through a boundary (walls, Circles of Power, Wards, etc) and may jump over or through anything to get to their location.

**Greater Holy Blessing**

**Tagged:** No  
**Used:** n/a      **Duration:** Constant  
**Category:** Follower of the Light

The character's Holy Blessing skill grants a +2 Strength Bonus instead of the normal +1 SB.

**Greater Perfect Aim**

**Tagged:** Yes  
**Used:** 1x/Tag Cycle      **Duration:** Instant  
**Category:** Warlock

Once per Tag Cycle the character can use this perk to Perfect Aim (as per the skill) a spell without any range limitation out doors.

**Greater Resist Evil**

**Tagged:** No  
**Used:** *Special*      **Duration:** Latent  
**Category:** Follower of the Light

The character can choose to change the duration of the Resist Evil skill from "instant" to "latent" and may target any character who is eligible to receive a Holy Blessing by touch. Using the skill in this fashion requires the use of the character's focus and a verbal which must be at least 5 syllables not including the skill's name and must contain the name of the skill. This boon cannot be used on the character themselves

**Greater True Aim**

**Tagged:** Yes  
**Used:** 1x/Tag Cycle      **Duration:** Instant  
**Category:** Warrior or Assassin

Once per Tag Cycle the character can use this perk to true aim (as per the skill) an attack without any range limitation out doors. They must still throw the weapon or ammunition.

**Greater Tree Walk**

**Tagged:** No  
**Used:** n/a      **Duration:** Constant  
**Category:** Druid

The character's *Tree Walk* spell allows them to take twice as long to get to their target tree. All other rules of the *Tree Walk* spell apply.

**Hated Enemy**

**Tagged:** Yes  
**Used:** 1x/Tag Cycle      **Duration:** Instant  
**Category:** General

The character with this boon gains Critical Attack skills that they can only use offensively and against a hated foe. Additionally, the character gains a +10 Damage Bonus (added after doubling) for that attack only. Acceptable categories are: Elves, Pantherghasts, Half-breeds, Green Skins (Orcs, Goblins, Hobgoblins), trolls, undead, and Scaven. Large catch all groups like: humanoids, living things, mammals, people, or everyone are not acceptable. The character must use a verbal before each attempt to use this skill. The verbal must be five syllables long plus the name of this skill (or a reasonably close version). For example, "For remembrance of the Mistwood, I strike down my hated foe, x Crit"

**Improvised Assassin**

**Tagged:** No  
**Used:** n/a      **Duration:** Constant  
**Category:** Assassin

When this boon is gained, the character may sacrifice a higher Build Point costing Dexterity tagged skill for a lower Build Point costing Dexterity tagged skill. The character must know the lower Build Point skill and they have to have the tag for the higher Build Point costing skill for that Tag Cycle. Skills that have the same Build Point cost cannot be substituted. While a Martial skill, the Assassin can substitute a Dexterity skill for Disarm. Skills that only appear on the Master Thief list cannot be used to substitute or be substituted for.

**Improvised Fighter**

**Tagged:** No  
**Used:** n/a      **Duration:** Constant  
**Category:** Warrior

When this boon is gained, the character may sacrifice a higher Build Point costing Martial skill for a lower Build Point costing tagged Martial skill. The character must know the lower Build Point skill and they have to have the tag for the higher Build Point costing skill for that Tag Cycle. Skills that have the same Build Point cost cannot be substituted.

**Latent Holy Blessing**

**Tagged:** No  
**Used:** *Special*      **Duration:** Latent, 10 Minutes

**Category:** Follower of the Light

When using the holy blessing skill the character can change the duration to "Latent, 10 minutes" instead of "10 minutes". All the other rules of Holy Blessing still apply. This boon cannot be used on the character themselves

**Master Alchemist**

**Tagged:** No  
**Used:** *Special*      **Duration:** Constant  
**Category:** Alchemist

This perk allows the character to re-roll a failed creation roll once. The player must accept the final roll.

**Master Brewer**

**Tagged:** No  
**Used:** *Special*      **Duration:** Constant  
**Category:** Alchemist

Each month, the character with this perk gains +10 Production Points that they can use at any rate with any school they know.

**Master Channeler**

**Tagged:** No  
**Used:** n/a      **Duration:** Constant  
**Category:** Channeler

This perk allows a character with the Channler skill to channel their spells though any weapon, not just a weapon of quality. Elementally aligned weapons still cannot channel any element other than their own.

**Master Sorcerer**

**Tagged:** No  
**Used:** n/a      **Duration:** Constant  
**Category:** Sorcerer

This perk gives the character an addition +5% Performance Bonus to their Ritual Success Rolls.

**Master Warlock**

**Tagged:** Yes  
**Used:** 1x per Event      **Duration:** Instant  
**Category:** Warlock

The character with this boon may combine one use of their Total Power and one use of their Perfect Aim Skills once per Tag Cycle.

**Natural Fighter**

**Tagged:** No  
**Used:** n/a      **Duration:** Constant  
**Category:** Warrior

The character has become naturally adept at using weapons and gains a +1 Damage Bonus (not from strength or proficiency) to all weapons the character has the skill to use.

**Power Reclamation**

**Tagged:** No  
**Used:** n/a      **Duration:** Constant  
**Category:** Mage

This boon allows the character to regain 1 Power Point every even month that has been lost. The character does not recover Power Points from the following effects: Build Point draining effects (Wights), Ritual of Investiture, or Ritual of Permanent Power Point Transfer.

**Rallying Cry**

**Tagged:** Yes  
**Used:** 1x/Tag Cycle      **Duration:** Instant  
**Category:** General

Once per Tag Cycle the character may make a rallying cry and dispel all fear effects to all friendly targets within the sound of their voice or Line of Sight. The character must use a verbal that is five syllables long plus contain the name of the boon.

**Resilient Healer**

**Tagged:** No  
**Used:** n/a      **Duration:** Instant  
**Category:** Follower of the Light

The character with this perk no longer falls asleep for 10 minutes after using their Life skill to heal another character.

**Resilient Warrior**

**Tagged:** No  
**Used:** n/a      **Duration:** Constant  
**Category:** Warrior

The Resilient Warrior takes 50 points of damage from Slay or Assassinate and 100 points of damage from Kill/Life effects. If the attack reduces the character to 0 Body Points or below then they are either Mortally Wounded or at the Brink of Death respectively.

**Ritual Expert**

**Tagged:** Yes  
**Used:** 2x/Event      **Duration:** Instant  
**Category:** Sorcerer

Twice per Event, the character can cast a Rank 1 Ritual without the Success Roll, performing the steps, having a marshal, or taking the time. Instead they must repeat a verbal agreed to by the Head of Plot and spend one minute performing some part of the ritual. The components and Power Points are expended as usual and should be brought to a marshal. The marshal will take the components and issue marshal notes for the ritual.

**Song of Greater Awakening**

**Tagged:** Yes  
**Used:** 3x/Event      **Duration:** Instant  
**Category:** Spell Singer

Three times per Event the character may use the Awaken Spell Song to awaken a Follower of Light from the unconsciousness caused by the Heal Life skill.



**Spell Reclamation**

**Tagged:** No  
**Used:** n/a                      **Duration:** Constant  
**Category:** Channeler

This perk allows the character to pick one spell that can no longer be cast due to Channeling and cast it again using a spell packet. This spell can still not be Channeled

**Spell Immunity Reclamation**

**Tagged:** No  
**Used:** n/a                      **Duration:** Constant  
**Category:** Warlock

This perk allows the character to pick one spell that can no longer be cast because they are immune to it from learning the Spell Immunity skill and cast it again. They are still immune to the spell.

**Surface Adaptation**

**Tagged:** No  
**Used:** n/a                      **Duration:** Constant  
**Category:** Racial

This perk allows a character to ignore their racial penalty (up to -1 Damage Bonus) for being on the surface/sunlight.

**Total Loyalty**

**Tagged:** No  
**Used:** n/a                      **Duration:** Constant  
**Category:** General

The character with this perk cannot be compelled by a charm effect to harm any member of the an organization to which they belong or a single person. The organization must be chosen at the time this perk is gained and cannot change. Even if the character is no longer part of that organization, they still cannot be forced to harm them. The names of the members will be recorded on the back of this player's card. Each name will be initialed by the Head of Plot or the marshal in charge of Heroic Boons.

**Trap Master**

**Tagged:** No  
**Used:** n/a                      **Duration:** Constant  
**Category:** Rogue

The Trap Master Perk gives all of the traps (except gas traps) an additional 5 points of damage at no additional Build Point Cost.

# Appendix D: Artists Credit Page

## Artistic Credits

---

Aimee Parmelee - Heraldry  
Albert Howe - Lich  
Alex Topaller - 'The Silent House' and 'Dragon'  
Alton Lawson - 'Catti Brie' and 'Just some Dark Elf with two swords...'  
Andrea 'Gelicht' Wimmer - 'Druid'  
Benjamin F. Battiste - 'Aleric Paladin of the Realms', 'Dragon', 'Swingin' the Hamm'r' and 'The Reaper'  
Brian Moyer – 'Barbarians' page 24 and 25, 'Dwarf' page 31, 'Saurian' page 33, 'Half-Ogre' page 35, 'Half-Troll' page 36, 'Half-Orc' page 40, 'Orc' page 254  
Bruce Huffman - 'Castle Myre' and 'Pagan Ruins'  
Daniel Rodriguez Millan - 'Vampire' and 'WolfExplorer' [soynegativo@hotmail.com]  
Dave Parmelee – Map of Avalon  
Edward Joel Wittlif - 'theives moon'  
Emil O. Carlström - 'Troll' and 'Trollhead'  
Eric Chapman - 'Cloaked Phantom' and 'Dark Elf Warrior'  
Eric Decluseau - 'dragon' and 'The Temple'  
Greg M. Bowtell - 'Tim... the Dragon'  
Gyula Pozsgay - 'Druid'  
Heidi Nickel - 'Lock Pick'  
Ilona Naomi Kaptein - 'If you don't have the password...I'll eat ya!!'  
Jesse Gillies - 'Ruins'  
John Kroetch - 'Mystical Ring'  
John Terrell Fell III - 'Daleth', 'Show-Down', 'Proud', and 'Serpent'  
Jonas Nelson - 'Axe', 'Dragon bath', 'Think twice', 'Fed up' and 'Crystal ball'  
Kalle Salava - 'Black dragon'  
Karl B. Heck - 'TIAX will slap you silly!...'  
Lance W. Card - 'Living Legend' [<http://www.the-crazed.com>]  
Marcel Soler - 'Battle'  
Maria J. William - 'OF WAR AND GLORY'  
Mark Lonsinger - 'Wood Elf'[[www.dracoart.deviantart.com](http://www.dracoart.deviantart.com)]  
Mats Orsch Andersson - 'orc warrior'  
Matteo Mazzacurati - 'The Adventurers'  
'The Adventurers' - 'Goblin axeman' and 'Skeletal Warrior'  
Mik Wilkens - 'Dragon Bookplate' [indicate copyrighted by him]  
Mikhail E. Merkurieff - 'gargoyles' and 'Battle Plans'  
Przemyslaw Swida - 'To bhuee or not to bla' and 'The warlock without face - picture without title'  
Roberto Campus - 'Vestal'  
Stellan Garhammar - 'Lord of Balrogs'  
Tommy Hween - 'Evilface I', 'Crusader' and 'The Vow'  
Vasilis Zikos - 'Yerevan the Druid'  
William Teo - 'Beyond the Veils'

---

The End

